

EMPOWERING MELTERS
EMPOWERING WHAT MATTERS

MICRON
by meler

MICRON+ DRUM

USER-DRIVEN INNOVATION
AND ENGINEERING



MICRON+ DRUM

EFFICIENCY AND TECHNOLOGY FOR MELTING ADHESIVE IN 20 OR 200 LITRE DRUMS

Drum unloaders with **Micron+ technology** to improve production processes using **reactive and non-reactive adhesives**.

CUTTING-EDGE TECHNOLOGY

THE BEST ENERGY EFFICIENCY ON THE MARKET

- ◆ Lowest energy consumption per kg melted/hour
- ◆ Equipment status change automation (up to 6 calendars and 6 status changes/day)

ADHESIVE CARE SAFETY

- ◆ Sequential heating by zones
- ◆ Thermal plate homogeneity
- ◆ Direct melting from packaging
- ◆ High adhesive flow speed
- ◆ Shut-down with no need for inert gas, maintaining the adhesive in perfect conditions

THE PEACE OF MIND OF CONNECTING WITH WHAT MATTERS

- ◆ 7" touchscreen, alerts for preventive maintenance, statistics and USB for updates, backup & datalogger
- ◆ Easy integration for Industry 4.0 (communication protocols)
- ◆ Real-time data monitoring

THE CONFIDENCE OF BEING IN CONTROL

- ◆ Advanced usability
- ◆ Password and user level management



DISTRIBUTION

10 outputs

4 on top of the melter plate and 6 in the new card developed

8 outputs

2 on top of the melter plate and 6 in the new card developed

THE OUTPUTS YOU NEED

A NEW CARD TO INCREASE THE NUMBER OF CONNECTIONS

MICRON+DRUM 20	MICRON+DRUM 200
	Pt100 and Ni20 probes, NTC
	Hydraulic: 2 outputs per pump
	Electrical: up to 10 outputs

CONTROL AND COMMUNICATION



ADHESIVE DELIVERING APPLICATION (ADA) for real adhesive flow control

- ◆ Integrated in the electronic platform, an application is available to help the system know which pump speed parameter it must activate to release the required amount of adhesive.



STARBI TECHNOLOGY for programming channels and patterns

- ◆ Easy to use, the Starbi pattern controller can program multiple patterns.



INTEGRATION of the latest connectivity

- ◆ Communication protocols to connect with the main machinery.
- ◆ Installed inside the machine, the connection allows you to read and write the most important parameters for machine operation.

GLUING TECH WITH MICRON+DRUM

AIR INJECTION

- ◆ Correct ejection of the melter plate with an automatic air injection system to counter the vacuum produced inside the drum. This process can also be completed manually.

NEW INTERFACE

- ◆ A new interface to simply and quickly connect two machines to work in tandem with just one cable.

Powered by:



TOTAL ACCES



ENERGY EFFICIENCY



ADHESIVE CARE

ADVANTAGES:



MAXIMUM ENERGY EFFICIENCY



IMPROVES PROCESS PERFORMANCE



MAXIMUM ACCESSIBILITY



EASY USE AND INSTALLATION



TOTAL CONNECTIVITY



COOL TOUCH

APPLICATIONS:

AUTOMOTIVE INDUSTRY



CONSTRUCTION



WOOD

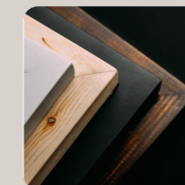

TEXTILES



MATTRESSES



ASSEMBLY



GRAPHIC ARTS



MICRON+ DRUM

DIMENSIONS:

MICRON+ DRUM 20

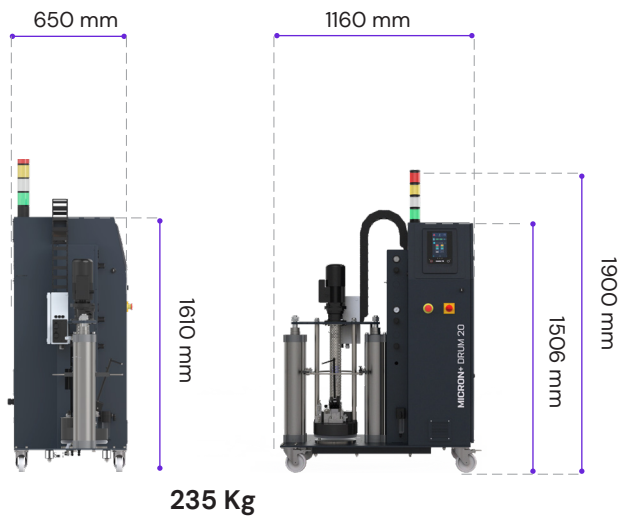

MICRON+ DRUM 200

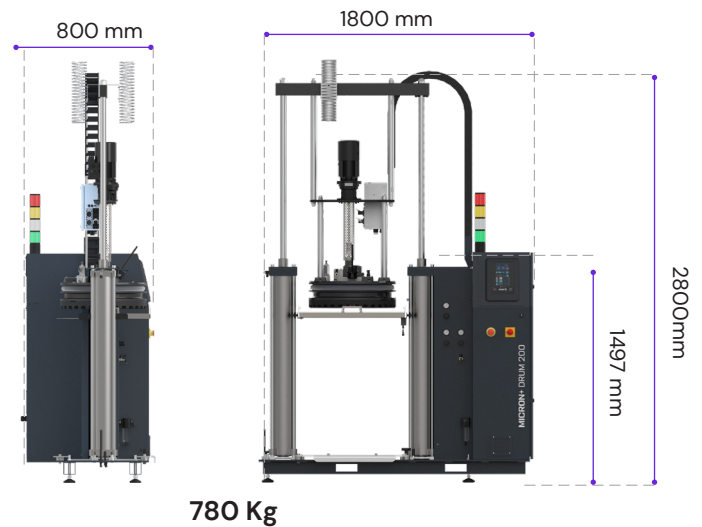

TECHNICAL SPECIFICATIONS:

	MICRON+ DRUM 20	MICRON+ DRUM 200
Size of drum to be used	Ø280 (interior) x 400mm (up to 20 litres) (Ø286 USA)	Ø571 (interior) x 950mm (up to 200 litres)
Type of melting plate	Smooth and radial fins	Smooth, radial fins and parallel fins
Melting rate (*)	Up to 18-20 kg/h	Up to 165 kg/h
Pumping capacity (*)	Single pump 1, 2.5, 4 and 8 cc/rev Double pump 2x0.93, 2x1.86, 2x3.71 and 2x4.8 cc/rev	1, 2.5, 4, 8, 15, 20 and 30 cc/rev 2x0.93, 2x1.86, 2x3.71 and 2x4.8 cc/rev
Number of pumps	1 single pump or 1 double pump	1 single pump or 1 double pump 2 simple pumps up to 8 cc/rev
Number of hydraulic outputs	2 per pump (3/4' UNF thread)	2 per pump (3/4' UNF thread)
Number of electrical outputs	Up to 10 outputs	Up to 10 outputs
Motor power	0.250 kW	0.375, 0.55, 0.75, 1.1 kW depending on type of pump
Speed	10-80 rpm (range 0-100 rpm)	10-80 rpm (range 0-100 rpm)
Temperature range	40 to 200°C	40 to 200°C
Temperature control	RTD ±0,5°C	RTD ±0,5°C
Maximum power pressure	80 bar (1.160 psi) (do not exceed 70 bar)	80 bar (1.160 psi) (do not exceed 70 bar)
By-pass valve	Pneumatic (manual or automatic pressure regulation) Mechanic	Pneumatic (manual or automatic pressure regulation) Mechanic
Maximum power supply	1 single pump/ 2 outputs - 5,000 W/ per phase 1 double pump/ 4 outputs - 5,000 W/ per phase	1 single pump/ 2 outputs - 9,900 W/ per phase 1 double pump/ 4 outputs - 11,700 W/ per phase
External functions	Temperature ok output, Empty drum output, Under maintenance input, External motor start-stop control, External motor speed control	Temperature ok output, Empty drum output, Under maintenance input, External motor start-stop control, External motor speed control
Electrical requirements	3N ~ 400V 50/60 Hz + PE 3~480V 50/60 Hz +PE	3N ~ 400V 50/60 Hz + PE 3~480V 50/60 Hz +PE
Options	Hose guide springs Adhesive Delivering Application (ADA)	Smoke extractor hood Hose guide springs Adhesive Delivering Application (ADA) Reinforced fixing for cardboard drums Wheels Hose guide springs

(*) Depending on adhesive type, melting plate type and working conditions