



STARBI 4 or 6 channels



STARBI 2 channels

PATTERN CONTROLLER STARBI

GLUING SOLUTIONS

Pattern controller for hot melt and cold glue applications at a variable speed of up to 600 meters/minute.

7" touchscreen with user friendly menu which adapts optimally to the needs of the user.

Programming for up to 6 applicators (with twin output connection) and up to 8 strokes per pattern.

High output power per channel (per pair of outputs).

Control by time or distance for three types of application: standard product, variable product or repeated product.

Security password for the stored data.

Possibility of backing up or updating software via USB port.

Features fail-safe input/output peripheral connectors (versions 4 and 6 channels).

TECHNICAL CHARACTERISTICS

Supply voltage	100-264 V / 47-63 Hz
Power	up to 25 W/channel (per pair of outputs)
Channels output voltage	24 VDC
Screen	7" Touchscreen
Output 0-10V (without insulation)	24 VDC (supply); 0 to 10 VDC (signal)
Output 0-10V (insulated)	0 to 10 VDC (signal)
Photocell/encoder	24 VDC (supply); 24 VDC PNP output (signal)
Number of Channels	2, 4 or 6
Number of Applicators per Channel	2
Number of Lines per Channel	8 (individual dotting)
Number of Photocells	up to 6 (according to number of channels)
Number of Encoder/Input 0-10 V	1/1
Number of Channel Inhibitors	1
Maximum speed of main machine	600 m/min
Minimum application speed	Programmable
Programming margin (encoder)	1-6550.0 mm
Programming margin (time)	1-6550.0 ms
Programmed tolerance	±0.1
Basic languages	German, Spanish, French, English, Italian and Portuguese
Communications (optional)	Modbus / Profibus
USB Port	For backing up and updating software (Windows app)

DIMENSIONS (*)

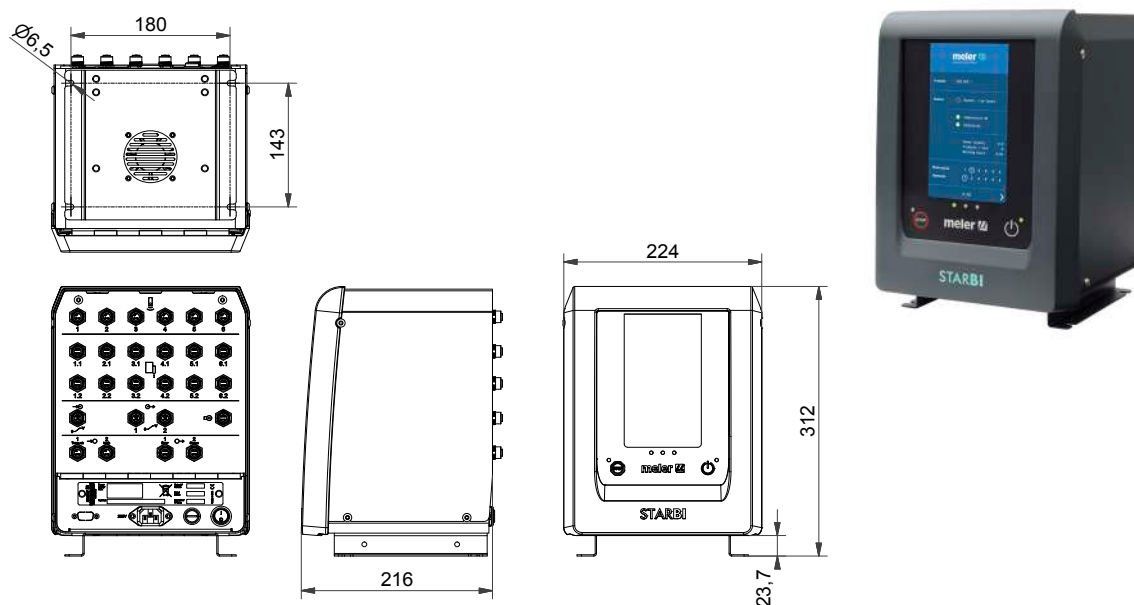

(*) For STARBI with 4 or 6 channels. For STARBI with 2 channels and other fastening accessories, inquire.

For more information speak with your Focke Meler representative:

meler 

Focke Meler Gluing Solutions, S. A.

Pol. Los Agustinos, c/G, nave D-43
E-31160 Orkoien - Navarra - Spain
Phone: +34 948 351 110
Fax: +34 948 351 130
info@meler.eu - www.meler.eu

A Focke Group Company

CE

