



INSTRUCTIONS
MANUAL

ADHESIVE MELTER **B4 VS**

Published by:

Focke Meler Gluing Solutions, S.A.

Pol. Arazuri-Orkoien, c/B, nº3 A
E-31170 Arazuri - Navarra - Spain
Phone: +34 948 351 110
info@meler.eu - www.meler.eu



Focke Group

Edition July 2021

© Copyright by Focke Meler

All rights reserved. Its reproduction, diffusion or use by electronic or other means of all or any part of this document without the express authorization of its owner is strictly prohibited.

The specifications and information contained in this manual may be modified without prior notice.

The official language of this manual is only the English language. The remaining versions of the manual in other languages are mere translations without any official value or efficacy. In case of discrepancies or contradictions between the English version of the manual and any other version of the manual written in another language, the English version will prevail.

TABLE OF CONTENTS

1. SAFETY GUIDELINES	1-1
General	1-1
Symbols	1-1
Mechanical components	1-2
Electrical components	1-2
Hydraulic components	1-2
Pneumatic components	1-2
Thermal components	1-3
Materials	1-3
Noise emission declaration	1-3
Intended use	1-4
Limited use	1-4
2. INTRODUCTION	2-1
Description	2-2
Intended use	2-2
Limited use	2-2
Operating modes	2-2
Melter identification	2-3
Main components	2-4
Optional Equipment	2-5
Control panel	2-5
Pumping control card components	2-6
3. INSTALLATION	3-1
Introduction	3-1

Installation requirements	3-1
Free space	3-1
Electrical consumption	3-2
Compressed air	3-2
Other factors	3-2
Unpacking	3-3
Contents	3-3
Mounting the equipment	3-3
Electrical power supply connection	3-3
Pneumatic connection	3-4
Hose and applicator connection	3-4
Programming parameters	3-5
Programming working temperatures	3-5
Selecting the overheating value	3-5
Keeping a component on display	3-6
External I/O connections	3-6
Temperature ok	3-7
External standby	3-7
Starting up the motor (ok ext)	3-8
Motor speed set point reference (ref ext)	3-9
Failures output in pump control card	3-9
4. MELTER OPERATION	4-1
General information	4-1
Loading the adhesive	4-2
Starting up the melter	4-2
Melter displays	4-3
Temperature display for each component	4-4
Alarm display	4-4
Temperature adjustment	4-5
Programming the melter parameters	4-6

Setting the clock	4-7
Setting the current day and time	4-7
Programming equipment activation/deactivation	4-8
Disabling the equipment activation/deactivation program	4-9
Programming the activation/deactivation of the equipment's standby function	4-9
Disabling the equipment standby function program	4-10
Special function buttons	4-11
Pump start-up	4-12
Pumping control	4-12
Starting up the pump control card	4-12
Pumping safety measures	4-13
Password security	4-13
LED indicators	4-14
Modes of operation	4-15
Mode of operation with internal pumping control and internal speed control	4-15
Mode of operation with internal pumping control and external speed control	4-16
Mode of operation with external pumping control and internal speed control	4-17
Mode of operation with external pumping control and external speed control	4-18
User configuration menu	4-19
Displaying alarms and reset function	4-20
Maximum rpm alarm	4-20
Minimum rpm alarm	4-20
Variator alarm	4-21
Configuring speed ramp	4-21
Programming speed ramp	4-22
Current Vin voltage display	4-23
Regulating the bypass valve	4-23
Adjusting the manual valve	4-24
Pneumatic valve control	4-24
Turning off the melter	4-24

5. MAINTENANCE	5-1
External cleaning	5-1
System depressurisation	5-2
Cleaning the tank	5-3
Changing adhesive type	5-3
Cleaning burnt adhesive	5-3
Emptying the tank	5-4
Filter maintenance	5-5
Pump maintenance	5-6
Leakage inspection	5-6
Gear motor maintenance	5-6
Cleaning the motor fan	5-6
Checking the lubricant	5-6
Recommended lubricant	5-6
Safety Thermostat	5-7
Removing the equipment from its base	5-7
6. TECHNICAL CHARACTERISTICS	6-1
General	6-1
Dimensions	6-2
Melting unit	6-2
Base plate	6-2
Accessories	6-3
Level control system	6-3
Air drying system for PUR adhesives	6-3
Automatic tank filling system	6-3
7. ELECTRICAL DRAWINGS	7-1

8. PNEUMATIC DRAWINGS	8-1
Components list	8-1
Pneumatic by-pass valve control system (optional)	8-1
Air drying system (optional)	8-2
9. SPARE PART LIST	9-1
A. TANK GROUP	9-3
B. DISTRIBUTOR UNIT	9-4
C. MOTOR- PUMP UNIT	9-5
D. ELECTRIC PANEL AND AUXILIARY COMPONENTS	9-6
E. WARNING LIGHT UNIT (OPTIONAL)	9-8
A1. SAFETY GUIDELINES	A-1
General	A-1
A2. INTRODUCTION	A-3
Main components	A-3
A3. INSTALLATION	A-5
Installation requirements	A-5
Free space	A-5
A4. MELTER OPERATION	A-7
Airtight lid	A-7
Configuration of air injection times	A-7
Filling the tank	A-8
A5. MAINTENANCE	A-9
Air dryer filter maintenance	A-9

A6. TECHNICAL CHARACTERISTICS	A-11
General	A-11
Dimensions	A-12
Melting unit	A-12
Accessories	A-12
Level control system	A-12
Air drying system for PUR adhesives	A-12
A7. ELECTRICAL DRAWINGS	A-13
A8. PNEUMATIC DIAGRAM	A-15
Component list	A-15
Air drying system (optional)	A-15
A9. SPARE PART LIST	A-17
A. AIR TIGHT LID	A-18
B. AIR DRYER SYSTEM	A-19
C. WARNING LIGHT UNIT (OPTIONAL)	A-20
EC DECLARATION OF CONFORMITY	10-1

1. SAFETY GUIDELINES

General

The information contained in this section applies not only to everyday equipment operation, but also to any procedure carried out on it, whether for preventive maintenance or in the case of repairs and the replacement of worn out parts.

It is very important to observe the safety warnings in this manual at all times. Failure to do so may result in personal injury and/or damage to the equipment or the rest of the installation.

Before beginning work on the equipment, read this manual carefully, and in case of any doubt, contact our Technical Service Center. We are available for any clarification that you might need.

Keep manuals in perfect condition and within reach of personnel that use the equipment and perform maintenance on it.

Also provide necessary safety material: appropriate clothing, footwear, gloves and safety glasses.

In all cases, observe local regulations regarding risk prevention and safety.



Symbols

The symbols used on both the melter/appliator equipment and in this manual always represent the type of risk we are exposed to. Failure to abide by a warning signal may result in personal injury and/or damage to the equipment or the rest of the installation.

Warning: Risk of electrical shock. Carelessness may produce injury or death.



Warning: Hot zone with high temperatures. Risk of burns. Use thermal protective equipment.



Warning: System under pressure. Risk of burns or particle projection. Use thermal protective equipment and glasses.



Warning: Important information for the correct use of the system. May include one or several of the previous hazards, and therefore must be kept in mind to avoid damage and injury.



Warning: Dangerous area. Risk of entrapment. Carelessness may produce injury or death.



Mechanical components



The hot-melt installation, which is installed to this device, requires moving parts that can cause damage. Use the equipment correctly, and do not remove the safety guards while the equipment is in operation; prevent the risk of possible entrapment due to moving mechanical parts.

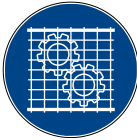

Do not use the equipment if the safety devices are not in place or appear to be inadequately installed.

For maintenance or repair operations, stop the movement of moveable parts by turning off the main switch.

The device has no moving mechanical parts, so it does not pose risks to consider in this section.



Electrical components



The system works with single-phase or three-phase current of a certain power. Never handle the equipment with the power connected, as this may result in powerful electrical shocks.

The installation must be correctly grounded.

The installation's power cable conductors must match the required electric current and voltage.

Periodically inspect the cables to check for crushing, wear and tear, as well as to prevent tripping and falls as a result of their placement.

Although the system meets EMC requirements, it is inadvisable to use devices that transmit high levels of radiation, i.e., mobile phones or soldering equipment in their vicinity.



Hydraulic components

As this is a pressurized system, precautions related to this type of equipment must be observed.

Before each operation, always make sure that the adhesive circuit is completely free of pressure. There is a high risk of hot particle projection, along with the corresponding danger of burns.

Use caution with the residual pressure that may remain in the hoses when the adhesive cools. When reheated, there is a risk of hot particle projection if the outputs are left open.

Pneumatic components



Some equipment uses compressed air to 6 bar pressure. Before any manipulation, please ensure that the circuit has lost fully air pressure. The risk of projection of particles at high speed can cause injury to a certain severity.

Extreme precautions with the residual pressure that could be contained in the circuit, before disconnecting any pneumatic feeding tube.

Thermal components

The entire system works with temperatures that can exceed 200°C (392°F). The equipment must be operated using adequate protection (clothing, footwear, gloves and protective glasses) that completely cover exposed parts of the body.

Keep in mind that, due to the high temperatures reached, the heat does not dissipate immediately, even when the power (in this case, electric) source is disconnected. Therefore, use caution, even with the adhesive itself. It may remain very hot, even in a solid state.

In case of burns:

1. If the burn is the result of contact with melted adhesive, do not try to remove the adhesive material from the skin. Do not try to remove it once it has solidified either.
2. Cool the affected area down immediately with lots of cold and clean water.
3. Seek medical attention as soon as possible either from the company's medical service or the nearest hospital. Provide the medical staff with the Safety Information Sheet of the adhesive.



Materials

Meler systems are designed for use with hot-melt adhesives. They should not be used with any other type of material, and especially not with solvents, which may cause personal injury or damage to internal system components.

Some units are specifically designed to use polyurethane reactive (PUR) hot-melt adhesives. Using PUR on a unit that is not prepared for that purpose may cause severe damage to the unit.

When using adhesive, follow the corresponding guidelines found in the Technical and Safety Sheets provided by the manufacturer. Pay special attention to the advised work temperatures in order to prevent adhesive burning and degradation.

Ventilate the work area adequately in order to remove the vapors produced. Avoid the prolonged inhalation of these vapors.

Always use original Meler components and replacement parts, which guarantee the correct system operation and service.



Noise emission declaration

The A-weighted emission sound pressure level (L_{pA}) of the unit in operation does not exceed 70 dB(A) under any circumstances.

The maximum C-weighted sound pressure level (L_{pCpeak}) and the A-weighted sound power level (L_{WA}) do not exceed values worthy of mention and thus do not represent a specific risk that must be taken into account.



Intended use

The equipment are designed to be used in the following conditions:

- Hot-melt adhesive fusion and pumping at temperatures up to 200 °C (392 °F). Consult with Meler technical service to operate with higher working temperatures.
- Use of equipment with Meler accessories.
- Installation of equipment according to the security regulations currently in force and the instructions provided in this manual (anchoring, electrical connection, hydraulic connection, etc).
- Use of equipment in non-explosive, non-chemically aggressive environments.
- Use of equipment following the safety instructions indicated in this manual, as well as on the labels accompanying the equipment, using adequate means of protection during each mode of operation.



Limited use

The equipment should never be used under the following conditions:

- Use with reactive polyurethane or any other material that might cause safety or health risks when heated.
- Use of equipment in environments where cleaning is necessary using water jets.
- Use of equipment to heat or melt food products.
- In potentially explosive atmospheres, aggressive chemical environments or outdoors.
- Use or operation without adequate safety protection.
- If the person in question does not have the necessary training to use the unit or to apply all of the necessary safety measures.



Note: Do not modify the equipment or use components that were not supplied by Meler. For any modification of a component of the equipment or part of the installation, you must firstly consult the After-Sales Service

2. INTRODUCTION

In this manual you will find information about the installation, use and maintenance of 'B4 VARIABLE SPEED' (hereinafter B4 VS), adhesive melter of Meler.

It is designed to be used commonly in manual applications with EVA based adhesives (or reactive adhesive like PUR when the air-tight lid and inner gas system is used) or simple automatic applications where a gear pump with variable speed is needed.



Description

Intended use

The B4 VS melter is designed for use in the following conditions:

- Melting and pumping hot-melt adhesives at a temperature of up to 200°C.
- Use of the melter with Meler accessories.
- Installation of the melter in accordance with the safety regulations in force and the instructions in this manual (fittings, electrical connection, hydraulic connection, etc.).
- Use of the melter in environments that are non-explosive and not chemically aggressive.
- Use of the melter in line with the safety instructions included in this manual, as well as on the labels included on the equipment, using adequate means of protection during each operating mode.

Limited use

The B4 VS melter should be used as intended and under no circumstances should it be used in the following conditions:

- Use with adhesives or any other material that could pose a safety or health risk when heated.
- Use of the melters in environments where waterjet cleaning is required.
- Use of the melters to heat or melt food products.
- Use or handling of the equipment without adequate safety protection.

Operating modes

The B4 VS melter can be used in the operating modes described below:

Operating mode_The melter keeps the hot components at the temperature indicated on the display, which has been preselected as the desired value. The pump-motor unit remains activated while it waits for a consumption request via the opening of one or two application guns.

Internal control of pumping and speed_Switches in the position ok 'int' and ref 'int'. In this mode of operation, the user has full control of pumping and the set speed of the pump rotation.

Control of internal pumping and external speed_Switches in the position ok 'int' and ref 'ext'. This mode of operation is performed through internal pumping control and speed control by means of an external 0-10 V signal sent from the main machine.

Control of external pumping and internal speed_Switches in the position ok 'ext' and ref 'int'. This mode of operation is performed through external pumping control and manual speed control.

Control of external pumping and speed_Switches in the position ok 'ext' and ref 'ext'. In this working mode, both pumping and speed are controlled from the main machine. Speed is controlled by means of an external 0-10 V signal sent from the main machine.

Standby mode_The hot-melt melter remains in a resting state, with the materials kept at (programmable) temperature values below the pre-selected value. The pump remains deactivated.

Alarm mode_The hot-melt melter detects a malfunction and warns the operator of this event. The pump remains deactivated.

Stop mode_The hot-melt melter remains off, without heating the materials and with the pump deactivated. The electrical and pneumatic supply remains activated between the network and the system, however.



Melter identification

You will need your melter model and reference when ordering spare parts or requesting support from our Technical Service Centre.

This data and other technical information can be found on the nameplate located on the side of the melter base.



Main components

- 1. Front control card.
- 2. Pumping control card.
- 3. Hose- applicator electrical connection.
- 4.Hose- applicator hydraulic connection.
- 5. General power switch and power supply
- 6. Pressure relief valve (for non-moisture curing adhesives).
- 7. Purge valve.
- 8. Filter pump.
- 9. Pump system connection switch (optional).
- 10. Warning light (optional).
- 11. Air tight lid (optional).
- 12. Air drying system (optional).

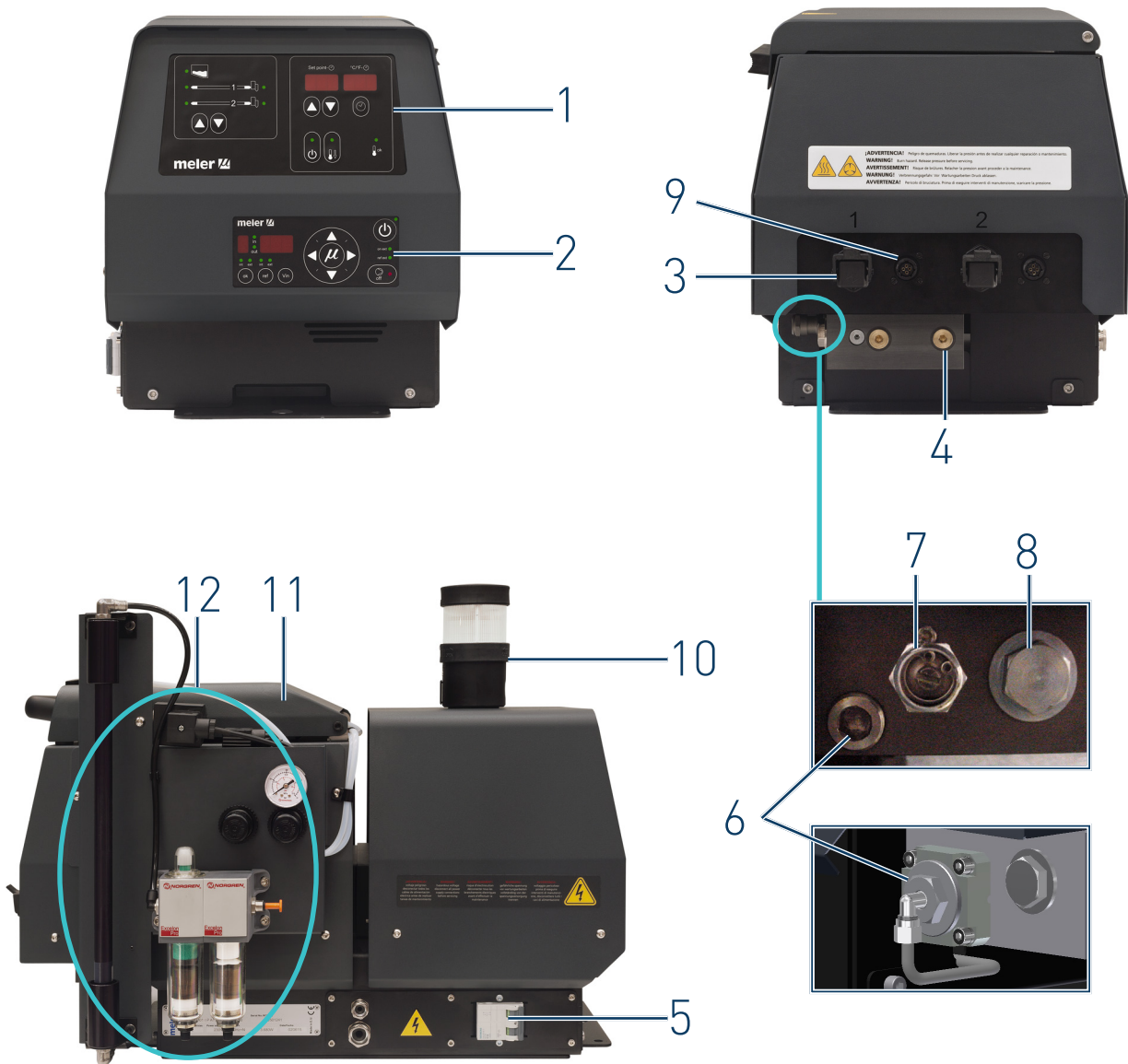

Optional Equipment

In order to provide the melting equipment with more functions, the following optional elements may be added:

- Air-tight lid.
- Air drying system for use with PUR adhesives.
- Automatic feeding system.
- Level detector with lighth tower.
- Activation pump mode by external switch (e.g. manual applicator).

Control panel

1. Tank indicator led.
2. Hose indicator led.
3. Applicator indicator led.
4. Temperature set point.
5. Actual temperature.
6. ON/OFF switch.
7. Standby function.
8. Temperatures ok led.
9. Timer programming.
10. Up/Down arrows for element selection.
11. Up/Down arrows for value modification.

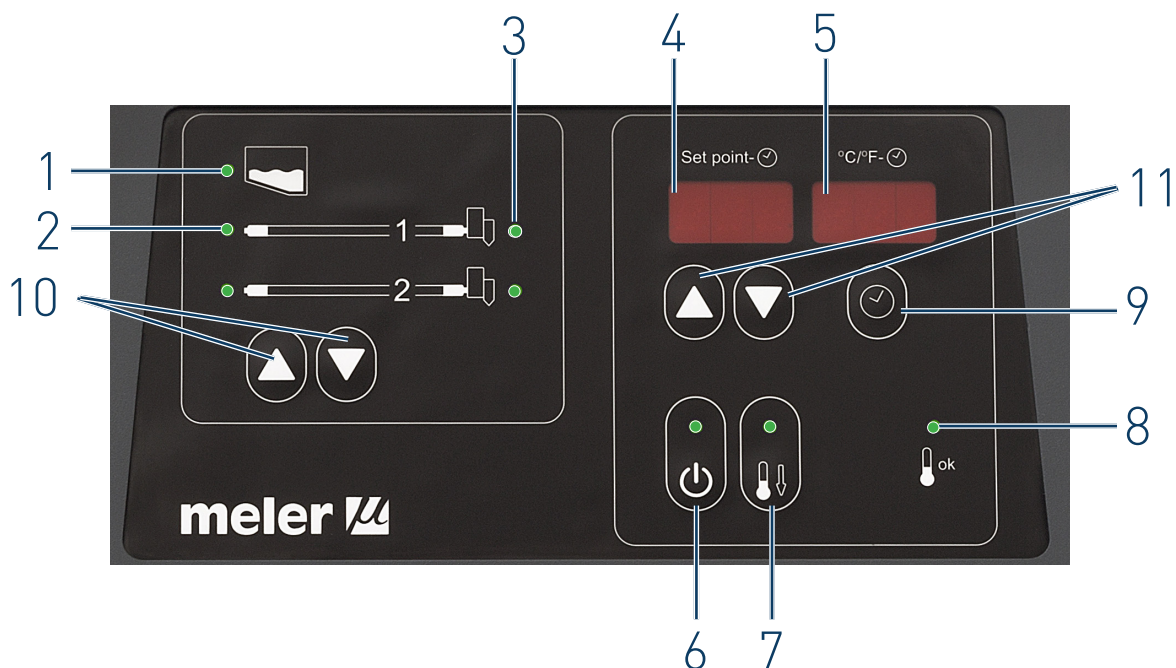

Pumping control card components

1. Main switch ON/OFF.
2. External start-stop LED.
3. External speed control LED.
4. Pumping permission LED.
5. Up/down arrow keys for selecting values.
6. Left/right arrow keys for selecting options.
7. Speed ramp steps display screen.
8. Speed ramp value selection LEDs (voltage/speed).
9. Voltage/ pump speed/ errors display screen.
10. Pumping control (internal/external) selection.
11. Pumping speed (internal/external) selection.
12. Voltage value display of the external signal of the speed control.

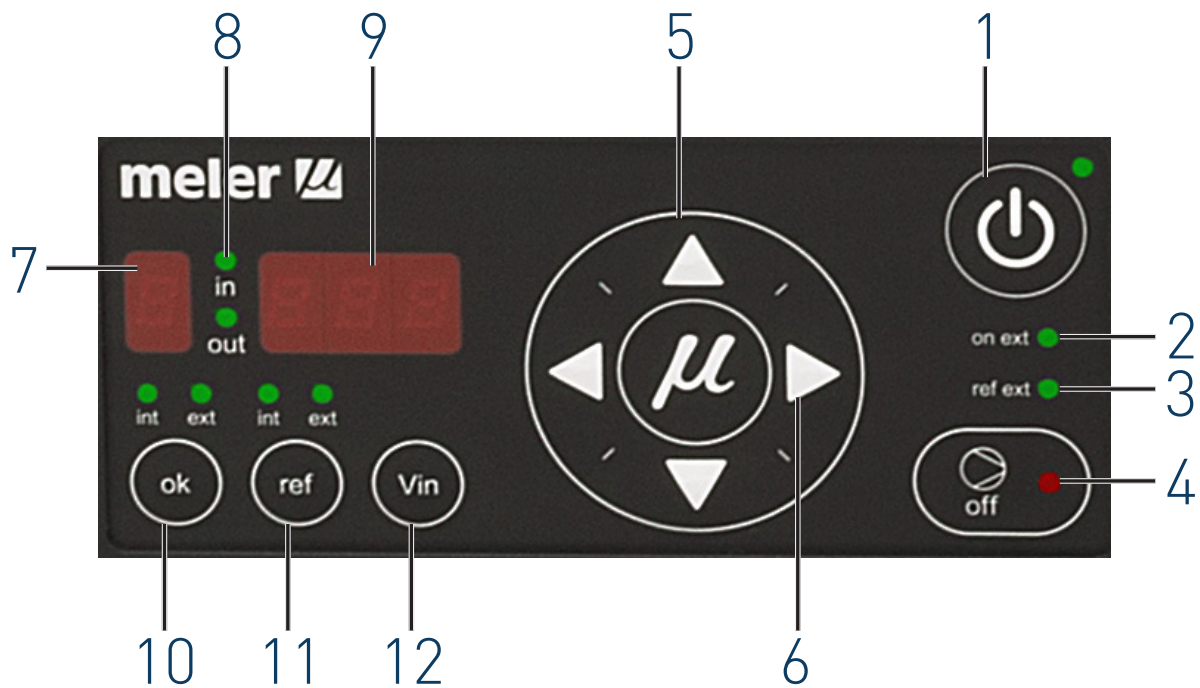

3. INSTALLATION

Warning: The melters are equipment with current technology and with certain foreseeable risks. Therefore, only allow qualified personnel with sufficient training and experience to use, install or repair this equipment.



Introduction

The B4 VS melter is supplied with all the components required for its installation. However, some components must be supplied by the user depending on the location and connections in each specific installation:

- Melter anchoring screws.
- Power cord for electrical power supply.
- Pneumatic conduct and connection to compressed air network.
- Stranded wire for external electric control functions.
- Optionally, a gas venting system.

Installation requirements

Before installing a B4 VS melter you must ensure that the space allocated is suitable for the installation, connection and use of the entire system. You must also ensure that the electrical and pneumatic supplies meet the requirements of the melter being installed.

Free space

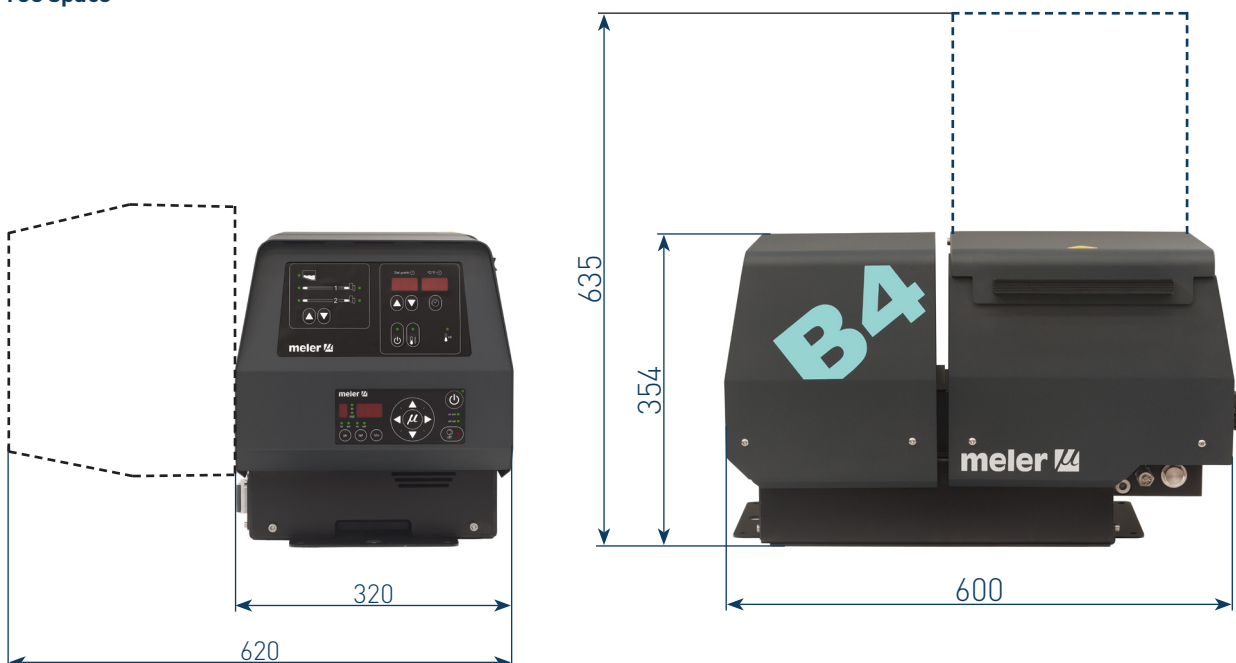



Electrical consumption

When installing a B4 VS melter, the installation's total consumption must be taken into account, including the consumption of the installed hose and applicator.

Before connecting the melter, make sure that the voltage to which it is to be connected is the same as that indicated on the equipment's nameplate.

Connect the melter and check that it is well grounded.

Warning: Risk of electrocution. Even when the melter is turned off, voltage remains in the input terminals, which could be dangerous when the equipment is handled internally.

The B4 VS melter should be installed with a power switch to disconnect it from its power supply source. A circuit breaker should be installed as personal protection against earth leakages.

The powers associated with these protections are indicated in the table in section 'Electrical power supply connection'.

Compressed air

The installation of melters from the B4 VS series requires a non-lubricated compressed air dryer system with a maximum pressure of 6 bar to supply the air drying system and the pneumatic bypass valve in case of the melter has any of them.

Other factors

Other practical considerations should be taken into account when installing the B4 VS melter:

- Make sure the load opening remains accessible to facilitate changing the adhesive block.
- Position the melter so that it is easy to see the front panel display where the temperatures and possible alarm signals are shown.
- As far as possible, try to avoid unnecessarily long hoses which consume a lot of electrical energy and result in high pressure drops.
- Do not install the melter next to powerful heat or cooling sources which may affect its operation.
- Avoid melter vibrations.
- Make sure that the melter maintenance areas (filter, purging valve, tank interior, gear motor, etc.) are easily accessible.

Unpacking

Before installing the melter, it should be removed from the pallet and inspected to detect any possible breakage or damage. Notify your Meler Representative or the Main Office of any defect, even to the outer packaging.

Contents

The B4 VS melter packing materials may contain accessories requested in the same order. Otherwise, the standard components included with the melter are as follows:

- Instruction manual
- Guarantee card

Mounting the equipment

The B4 VS melter includes an assembly base plate for easy mounting.

The base plate makes it easy to remove and position the melter. To mount the base plate, place it on the machine bench and position. Mark and drill four holes for the base plate's M8 fastening screws. The holes may be threaded or through holes depending on the bench on which they are being mounted.

Warning: Make sure the bench on which the base plate is being mounted is level, free from vibrations and able to support the weight of the equipment plus the full tank load.

Once the base plate has been secured to the bench, the melter should be mounted on top.

Fit the retaining flanges onto the base and position the four fastening screws.



Electrical power supply connection

The B4 VS melter is designed to be connected to the electrical power supply with single-phase 230 VAC and neutral, depending on the power consumption.

In any case a good ground connection is required.



The maximum consumption values are shown in the table attached:

Unit	Pump	No. Outputs	Max. connecting power	
			unit only	with outputs installed
B4 VS	gear	2	9,7A	16A

Warning: Risk of electric shock. Carelessness may cause injury or death.



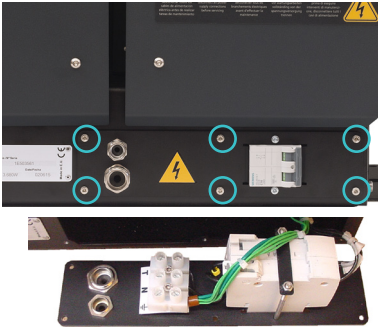

Remove the six screws fastening the connection support plate and power switch, on the left side of the equipment. Pass the power cable ($\varnothing 6-12$ mm) through the Pg13 bushing and fasten as shown in the figure, ensuring that the cable is perfectly secure and that it does not impede the mounting of the plate.

Connect each of the power cable's wires in their corresponding position in the input terminals.

Pneumatic connection

Before connecting the pneumatic supply to the air drying system or to the bypass valve (optionals), ensure that the pressure regulators are fully closed. To do this, turn both regulators control anti-clockwise.

Connect the plant's air supply (6 bar max.) to the equipment input using a flexible tube with an outer diameter of 6 mm. The melter has a quick release coupling for this purpose.

Allow the air to flow and turn the pressure regulator clockwise until the desired pressure is reached.

Hose and applicator connection

The B4 VS melter can use standard Meler components. The entire range of Meler hoses and applicators may be connected to this equipment.

The B4 VS melter has two outputs for connecting the hose-applicator for only one installed pump. These are identified on the same plate with the numbers 1 and 2. These numbers correspond to the control channels which appear on the front control panel.

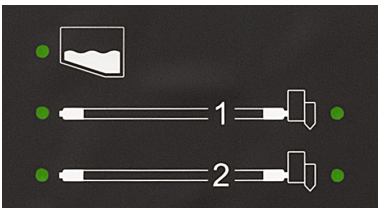

Warning: When connecting the hose-applicator outputs, check that the power connected does not exceed the maximum power allowed.

Caution:

- To identify each hose-applicator pair, electrically connect them to the connector with the same number as the output used.
- It is preferable to use couplings at 45° or 90° to minimise the space occupied by the hose. Straight couplings usually generate very small radii of curvatures that may damage the inside of the hose.
- Save the threaded cap which is removed from the distributor when connecting the hose. It may be required in the future if the hose is removed from its position.
- Electrically connect the hose and applicator when the equipment is turned off. Failing to do so may result in electrical defects in the connection and alarm messages may appear on the melter display.



Programming parameters

Once the melter and its components have been installed, the correct working parameters must be programmed for the specific application to be performed.

The B4 VS melter simplifies this task as much as possible, allowing the operator to change only those parameters which are necessarily variable for each application.

Among the different parameters, it is necessary to program the set point temperature values for each component connected and the value for the overheating warning. Other parameters (weekly start/turn off programming or the standby temperature value) are required in advanced systems, with the factory default values being perfectly valid for operational purposes.

Programming working temperatures

The melter's default set point temperature values are:

- 160°C (320°F) for the tank.
- 150 °C (302 °F) for the hoses and 160 °C (320 °F) for applicators.

The general process for changing the set point temperature value for any component is described below.

1. Use the arrows to select the component for which you wish to change the value.

The corresponding LED will blink rapidly.

2. Use the up-down arrows under the display to select the desired value for the set point temperature.
3. After ten seconds the LED will stop blinking and the display will change by default to the tank set point temperature, saving the changed data.

Repeat this step for each of the components installed in the melter.

Selecting the overheating value

1. Press simultaneously the clock and down arrow buttons, located under the display, to enter the special menu.

The choice of temperature display units (°C or °F) appear on the display.

2. Use the down arrow on the left side of the front card (component selection) to move to the next screen where the overheating symbol is displayed. **■■■■■**

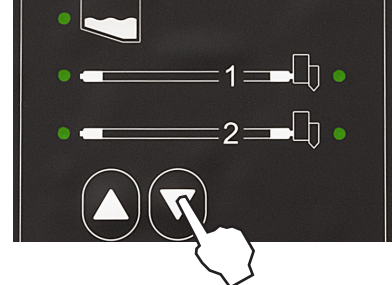
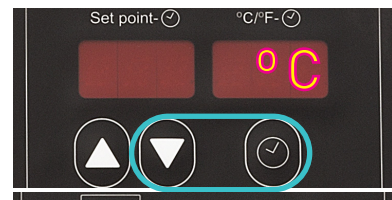
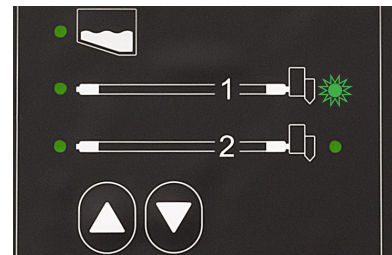

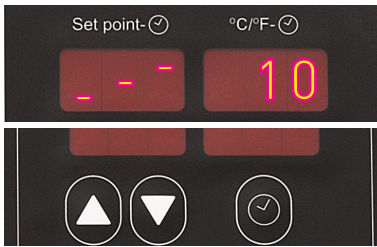

- Use the up-down arrows on the right of the front card to select the desired value.

The value displayed corresponds to the increase in real temperature over the set point temperature permitted without activating the alarm message (between 10 and 25).

- Use the down arrow on the left of the front card (component selection) to move to the next screen.
- Use the up arrow to exit the special menu; the tank's temperatures are displayed once again.

All of the values in the special menu are saved.

Keeping a component on display

By default, the main display shows the tank temperatures. However, it is possible to indefinitely display the temperature of any component for their analysis or control.

- Use the up-down arrows to permanently display the desired component.

The corresponding LED will blink rapidly.

- Hold the arrow button on the desired component for two seconds.
- The display will now remain on the selected component and will not be changed.
- Simply press the up-down buttons again to restore the default display (tank).

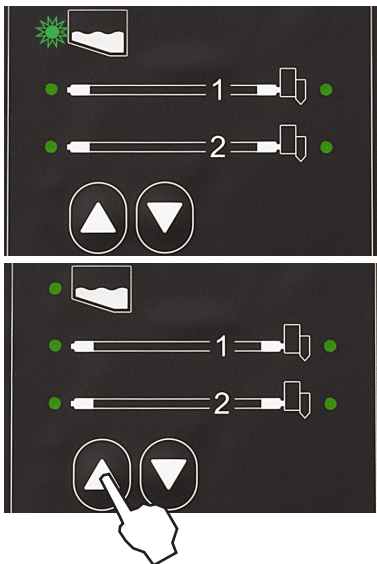

External I/O connections

The melter uses its input and output (I/O) signals to communicate with the main machine simply and directly.

There are four signals that may be used to communicate with the main machine:

- Temperature ok**_non-voltage contact output which notifies the main machine that all the system temperatures have reached a value which is 3° below the set point value (and that the time delay has elapsed), at start-up, or that the real value is not 20°C below the set point value during operation.
- External standby**_control input from the standby mode, via a non-voltage contact. When the contact is closed the standby function is connected; when the contact is open the function disconnects.

- **Motor start up**_for each pump installed, the motor start up may be controlled by closing an external non-voltage contact.
- **Motor speed set point**_for each pump installed, the rotational speed of the motor (and therefore, the pump) may be controlled by means of a 0 to 10V DC external signal.
- **Failures output in pump control card**_output from a non-voltage contact that communicates normally to a warning light beacon the failure from the pump control card.

Warning: Risk of electric shock. Carelessness may cause injury or death.



Temperature ok

1. If only this signal will be connected, use a 0.5 mm² two-wire cable.

Install a Pg9 bushing on the equipment base plate, next to the electric power supply unit.

2. Remove the six screws fastening the connection support plate and power switch, on the left side of the equipment. Pass the signal cable (Ø4-8 mm) through the Pg9 bushing and attach it to the internal fitting, ensuring that the cable reaches the control board connector at the point where it is to be installed (CN4).

3. Remove the connector from the panel and connect the two cable wires to their corresponding connector terminals:

1 contact NO

3 contact NO

4. Reconnect the connector to the panel.

5. Check that the cable is correctly connected and that its passage through the electric cabinet presents no risk of jamming, being cut or any other accidental damage.

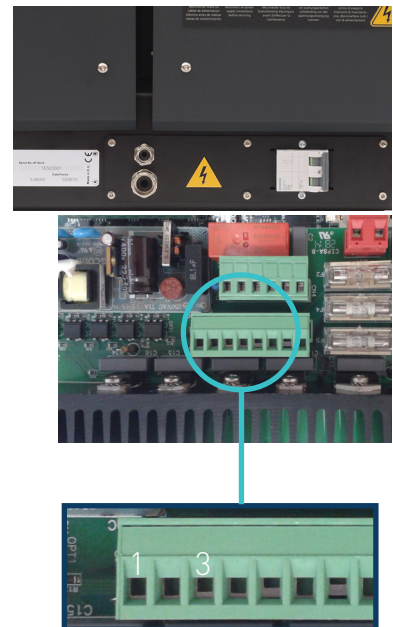

Warning: Connect to 24 V (AC or DC). If connected to 230 V the load current cannot be less than 50 mA.



Note: take into account the image of CN4 temperature ok connector, do not confused with CN4 external standby connector.



External standby

1. If only this signal will be connected, use a 0.5 mm² two-wire cable.

Install a Pg9 bushing on the equipment base plate, next to the electric power supply unit.



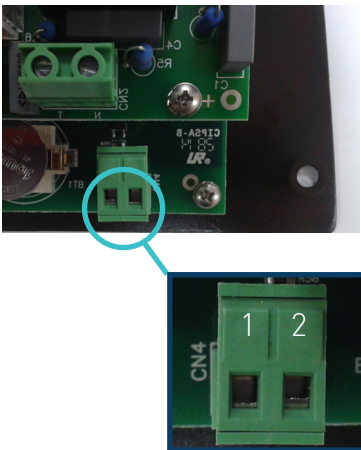

2. Remove the six screws fastening the connection support plate and power switch, on the left side of the equipment. Pass the signal cable (Ø4-8 mm) through the bushing Pg9 and attach to the internal fitting, ensuring that the cable reaches the control board connector at the point where it is to be installed (CN4).
3. Remove the connector from the panel and connect the two cable wires to their corresponding connector terminals:
 - 1 contact NO
 - 2 contact NO
4. Reconnect the connector to the panel.
5. Check that the cable is correctly connected and that its passage through the electric cabinet presents no risk of jamming, being cut or any other accidental damage.



Warning: Connect to 24 V (AC or DC). If connected to 230 V the load current cannot be less than 50 mA.

Note: take into account the image of CN4 external standby connector, do not confused with CN4 temperature ok .

Starting up the motor (ok ext)

1. If this is the only signal being connected, use 0.5 mm² two-wire cable.

Install an electrical wall bushing Pg9 next to the electrical supply input.
2. Thread the power cord (max. Ø4-8mm) through the electrical wall bushing Pg9 and fasten it to the inside anchor, making sure that the cord reaches the power card connector.
3. Connect the two wires from the start-up signal to the terminals XP1 and XP2. This is a double terminal, which makes it necessary to connect each wire in one of the two holes in the terminal. Since this contact is not under voltage, there is no connection polarity.
4. Make sure that the cables are firmly attached by the terminal screws.
5. For the signal to work, the led 'ok ext' on the control panel must be on.

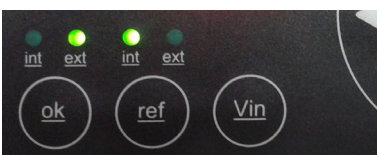
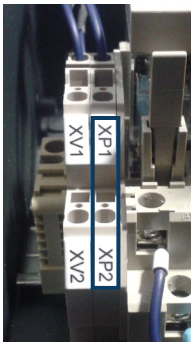

Motor speed set point reference (ref ext)

1. If this is the only signal being connected, use 0.5 mm² two-wire cable.

Install an electrical wall bushing Pg9 on the equipment base plate next to the electrical supply input.

2. Thread the power cord (max. Ø4-8mm) through the electrical wall bushing Pg9 and fasten it to the inside anchor, making sure that the cord reaches the power card connector.
3. Connect the two wires from the start-up signal to the terminals XV1 and XV2. This is a double terminal, which makes it necessary to connect each wire in one of the two holes in the terminal. The positive signal wire must be connected to point XV2 of the terminal, while the negative wire must be connected to point XV1.
4. Make sure that the cables are firmly attached by the terminal screws.
5. For the signal to work, the led 'ref ext' on the control panel must be on.

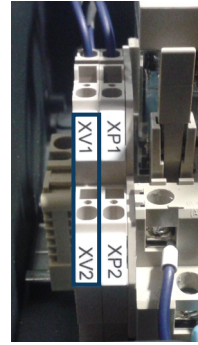

Warning: When connecting the 0-10V signal to the equipment. Make sure that the signal is not inverted or the signal applied is not excessive (more than 10 volts). Connect to inappropriate voltage or a wrong installation can result in an unpredictable behavior and even irreversible damage.



Failures output in pump control card

1. If this is the only signal being connected, use 0.5 mm² two-wire cable.

Install an electrical wall bushing Pg9 next to the electrical supply input.

2. Remove the six screws fastening the connection support plate and power switch, on the left side of the equipment. Pass the signal cable (Ø4-8 mm) through the bushing Pg9 and attach to the internal fitting, ensuring that the cable reaches the control board connector at the point where it is to be installed (S4).
3. Remove the connector from the panel and connect the two cable wires to their corresponding connector terminals:

- 1 contact NO
- 2 contact NO

4. Reconnect the connector to the panel.

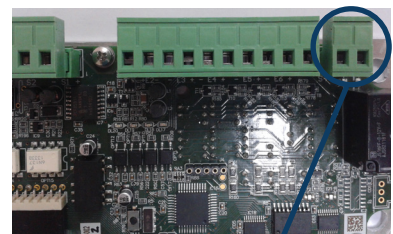

5. Check that the cable is correctly connected and that its passage through the electric cabinet presents no risk of jamming, being cut or any other accidental damage.



Warning: It must be connected to 24 AC or DC voltage with a maximum current of 1A.

4. MELTER OPERATION

This section explains how to operate the melter. Although the equipment is very easy to operate, it should not be used by untrained personnel.

Warning: Improper use may cause damage to the equipment itself or the person using it and can even result in death.



General information

There are three large groups of thermally controlled components in a hot-melt installation: the melter unit, the transport hoses and the applicators. All of these are controlled from the melter's front panel.

The first large group is the tank-distributor-pump unit. They form one single unit and have the same temperature control and set point value. Therefore, when the set point value for the cylindrical hopper is set to 170°C, for example, this same value is set for the distributor and pump.

The second group is the hose unit. These are identified on the front panel with the numbers 1 and 2 and the corresponding hose drawing. Each hose has its own set point value.

The third group is the applicator unit. These are identified on the front panel with the numbers 1 and 2 and the corresponding applicator drawing. Each applicator has its own set point value.

The hose and applicator numbers are automatically assigned to the hose/applicator channel to which they are connected via the connector on one side of the melter.

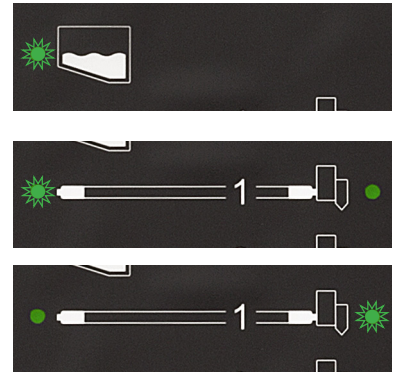



Loading the adhesive

To fill the tank:

1. Open the tank lid.
2. Use a shovel or a ladle to fill the tank with adhesive. Do not fill the tank above the loading opening level. The lid must be able to close normally.

Warning: Risk of burns. Always wear protective gloves and safety glasses when refilling.

3. Close the lid when you have finished refilling the tank.

Warning: Before refilling the tank, make sure that the adhesive is the same type as that already in the tank. Mixing different types of adhesives can cause damage to the melter/applicator equipment.

'B4 VARIABLE SPEED' melter has a tank capacity of 4 liters (4 kg for an adhesive density of 1 g/cc).

Starting up the melter

Before starting up the equipment, check that the unit is correctly installed and that all the input/output and accessory connections have been established.

Also check that the equipment has been filled with the adhesive to be used and that the working parameters have been programmed.

To start:

1. Connect the melter's power switch.

If the control board was turned off the last time the equipment was disconnected, this will remain off on restarting (time display).

If the control board was on the last time the equipment was disconnected, it will turn on again when restarted.

2. If it is not already activated, turn on the control board by pressing the ON/OFF button.

By default, the tank set point value and temperature are displayed.

The tank heating control LED (green) will light up and the tank will begin to heat. The LEDs for the hoses and applicators connected will also come on.

Once the tank has reached 3°C below the temperature set point value, a programmable delay timer is activated until a signal is given to start the pump (activation of the solenoid valve or turning of the motor) and connect to the main machine, provided that the other components have also reached 3°C below their set point temperature.

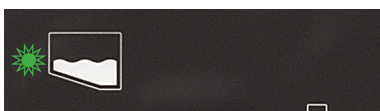
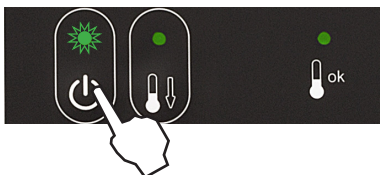

While the system counts down the delay time, the LEDs for pump activation and connection to the main machine continue to blink until the selected temperature has been reached, when the LEDs will remain on. If, after this time, any of the components has not reached 3°C below the set point value, the LEDs will turn off.

If the system is disconnected by pressing the off or standby button, by programming disconnection or activation of standby, by disconnecting the power supply or external activation of standby, when the system is restarted, the delay will only be activated if the tank temperature has fallen 20°C below the set point temperature.

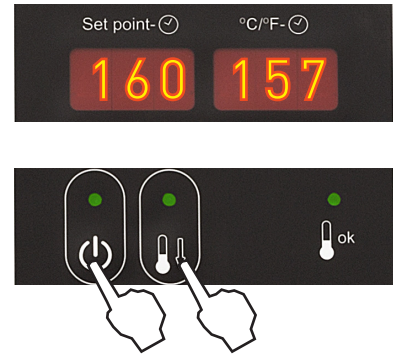

Melter displays

The control panel on the B4 VS melters have two displays, each with three sets of 7 segments to display the temperature values (set point and actual temperature), the programmable parameters and alarms.

They are equipped with LED indicators to display the heating of each component, as well as the pump activations and the main machine connection signal:

LED display	Component heating	Component status
constantly lit	constant	low temperature
blinking slowly	as need (according to PID parameters)	temperature near set point
blinking rapidly	programming or display	change in set point values
off	not heating	temperature reached

They are also equipped with LEDs indicating the programming of the equipment connection/disconnection and the connection/disconnection of the standby function:

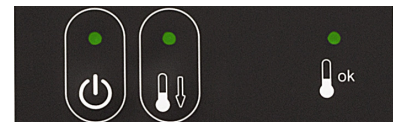

LED display	On/off	Standby
constantly lit	turned off unit	function activated
blinking slowly	deactivation programmed for the current day	activation programmed for the current day
blinking rapidly	activation/deactivation programming mode	activation/deactivation programming mode
off	unit in operation	function deactivated
simultaneous intermittence from leds of pump activation and main machine signal	timing in progress, once the tank has reached its set point temperature	

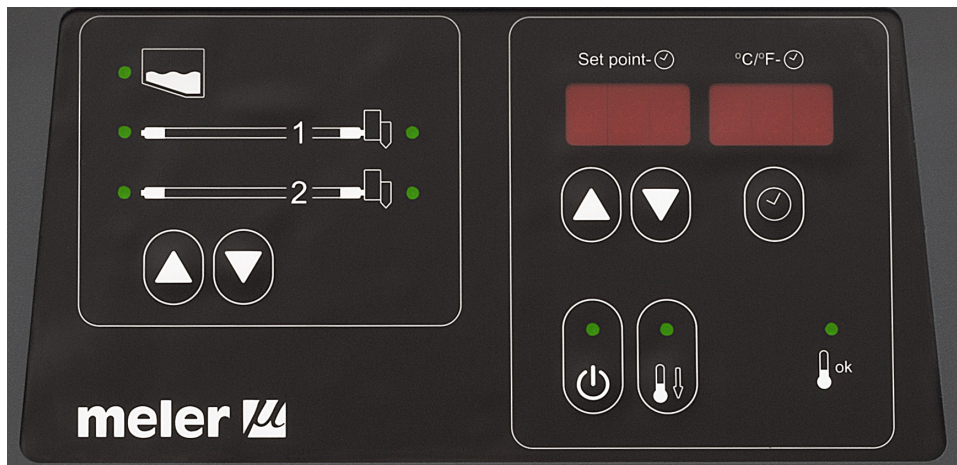

Temperature display for each component

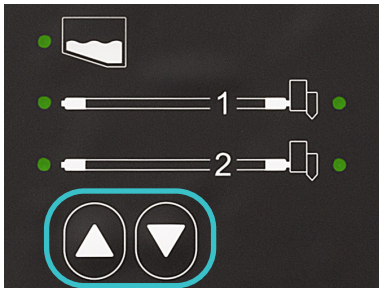

The temperature of each component (tank and each hose and applicator) can be displayed by selecting the component using the cursors.

Press the component selection up/down arrow until the desired component is displayed.

After 10 seconds the display returns to the default component (tank).

If you would like the component to be displayed permanently press the up-down button for 2 seconds on the selected component.

The display sequence is as follows:

tank←hose1←applicator1←hose2←applicator2

tank→hose1→applicator1→hose2→applicator2

To permanently remove a component from the display, simply press any of the up-down arrows.

Alarm display



The B4 VS melters inform the user when there is a malfunction in the unit, by sending messages that can be seen on the control panel display.

When an alarm appears, the control should take a series of actions to protect the unit. Simply correct the fault and the control will reactivate the equipment's functions.

Activating the standby function does not trigger any alarm.

If the sensor is broken, the system will keep all the components hot, except for the one in which the fault has occurred.

In the event of overheating, the system immediately stops heating the failed component. If after three minutes, the fault persists, the system will stop heating all components and the power relays will be disconnected. The panel will continue to display the alarm until the error has been rectified. Once resolved, the power relays will be reactivated and the system will begin to heat as normal.

Code	Cause	Actions		
		Heating	Pump	Main machine signal
Err 0	tank broken sensor	only tank off	off	off
Err 1	hose1 broken sensor	only hose1 off	off	off
Err 2	applicator1 broken sensor	only applicator1 off	off	off
Err 3	hose2 broken sensor	only hose2 off	off	off
Err 4	applicator2 broken sensor	only applicator2 off	off	off
Err 100	tank overheating	all components off	off	off
Err 101	hose1 overheating	all components off	off	off
Err 102	applicator1 overheating	all components off	off	off
Err 103	hose2 overheating	all components off	off	off
Err 104	applicator2 overheating	all components off	off	off

Temperature adjustment

By default, the melters have the following parameter values:

- Tank and distributor set point temperature: 160°C
- 150°C for hoses and 160°C for applicators
- Display in °C
- Overheating value: 20°C
- Standby value: 40%
- Delay time: 10 mins
- Time programming: ON

The general procedure for adjusting the temperature of each of the components is described below.

1. Use the up-down arrows to select the component for which you wish to change the value.

The corresponding LED will blink quickly.

2. Use the up-down arrows under the display to select the desired value for the set point temperature. Below 40°C, the temperature value displays 'OFF', cancelling the heating of this component (hoses and applicators only).

3. After ten seconds the LED will stop blinking and the display will change by default to the tank set point temperature, saving the changed data.

Repeat this simple procedure for each of the components whose set point temperature you would like to change.

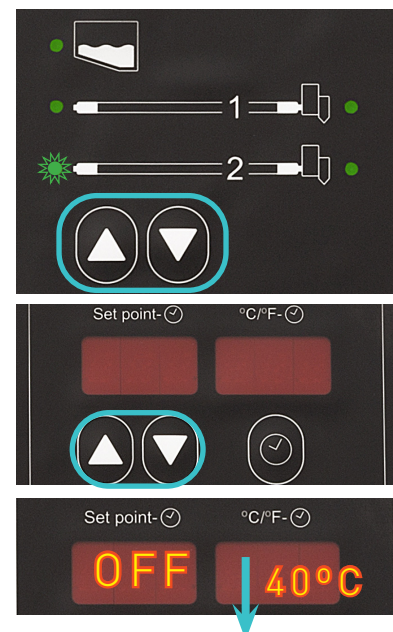

Programming the melter parameters

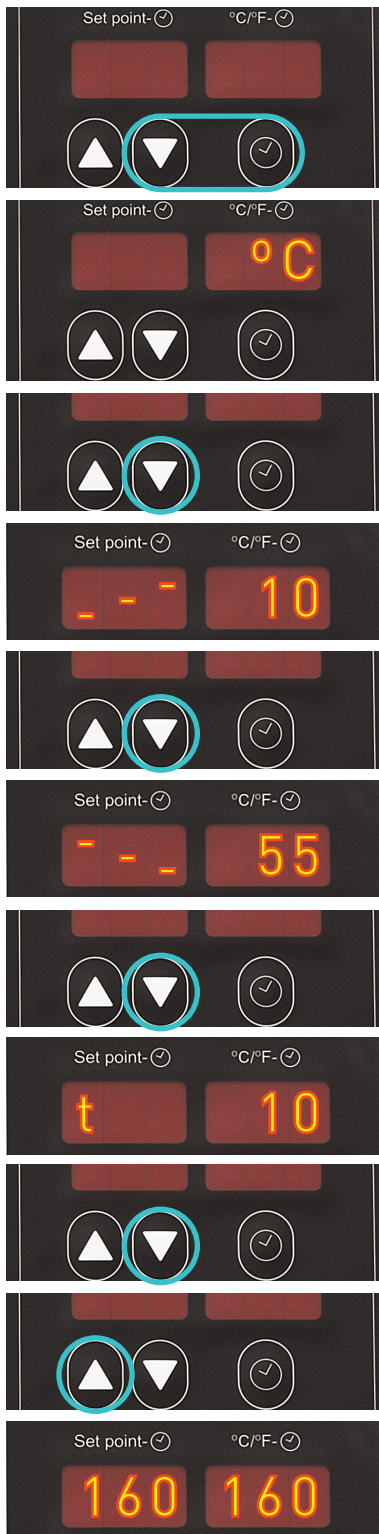

1. Simultaneously press the buttons with the clock symbol and down arrow to enter the special menu.

The choice of temperature display units (°C or °F) appear on the display.

2. Use the up-down arrows to select the desired value.
3. Use the component selection down arrow to move to the following screen where the overheating symbol appears.



4. Use the up-down arrows under the display to select the desired value (between 10 and 25).

The value displayed corresponds to the increase in real temperature over the set point temperature permitted without activating the alarm message.

5. Use the component selection down arrow to move to the following screen where the standby function symbol appears.



6. Use the up-down arrows under the display to select the desired value (between 25 and 55).

The value displayed corresponds to the percentage decrease in actual temperature below the set point temperature that will occur when this function is activated.

7. Use the component selection down arrow to move to the following screen where the delay time value appears.

8. Use the up-down arrows under the display to select the desired value (between 0 and 60 mins).

9. Use the component selection down arrow to return to the first parameter.

10. For any parameter, use the component selection up arrow to exit the special menu and display the tank's temperatures again.

To save any parameter, you must move to the next parameter using the component selection down arrow.

Setting the clock

The B4 VS melter has a weekly programmable system to control the connection and disconnection of the equipment and activate and deactivate the standby function.

Before programming these functions, the day and time the system will use to execute these programs must be entered into the control panel.

Setting the current day and time

1. Press the button with the clock symbol.

'0' will appear on the display indicating the program for setting the current day and time.

2. Press the button with the clock symbol again.

The left display shows the time with a dot, indicating that this is the value that can be changed, while the minutes are shown on the second display.

3. Use the up-down arrows under the display to select the desired value.

4. Press the button with the clock symbol again.

Now the dot appears on the display on the right.

5. Use the up-down arrows under the display to select the desired value.

6. Press the button with the clock symbol again.

A number appears indicating the day of the week (1- Monday / 7- Sunday).

7. Use the up-down arrows under the display to select the desired value.

8. Press the button with the clock symbol again.

The '0' program appears once again.

9. Press any of the up-down component selection buttons to exit this program and return to the tank temperature display.



Programming equipment activation/deactivation

An activation and deactivation time can be set for each day of the week, from Monday (1) to Sunday (7).

Time is expressed in increments of 15 minutes, starting with 10.0 (10 hours 0 minutes), then 10.1 (10 hours 15 minutes), 10.2 (10 hours 30 minutes) and 10.3 (10 hours 45 minutes).



1. Press the button with the clock symbol.

'0' will appear on the display indicating the program for setting the current day and time.

2. Use the up-down buttons under the display to select the value for the desired day of the week, Monday (1) to Sunday (7).

3. Press the button with the clock symbol again.

Two times will appear, one in each display. The display on the left shows the start time while the display on the right shows the end time.

4. The flashing dot on the start time display indicates that this value can be changed. Use the up-down arrows under the display to select the desired value.

5. Press the button with the clock symbol again.

The dot then appears on the end time display.

6. Use the up-down arrows to select the desired value.

7. Press the button with the clock symbol again.

The selected program appears once again. Use the up-down button to select other programs.

8. Press any of the arrow buttons on the left or right to exit this program and return to the tank temperature display.

The green LED next to the 'ON/OFF' button will always blink if a disconnection time has been set for the current day.

Disabling the equipment activation/deactivation program

The programmed equipment activation/deactivation can be disabled without having to cancel the daily programming. In this way the programmed data is saved but the programming has no effect on the equipment.

1. Press the button with the clock symbol.

'0' will appear on the display indicating the program for setting the current day and time.

2. Use the up-down arrow under the display to skip past the selection for the last day of the week (7).

'ON/OFF' will be displayed depending on the current status.

3. Press the button with the clock symbol again.

The status will alternate each time you press the button.

4. Press any of the up-down component selection buttons to exit this program and return to the tank temperature display.

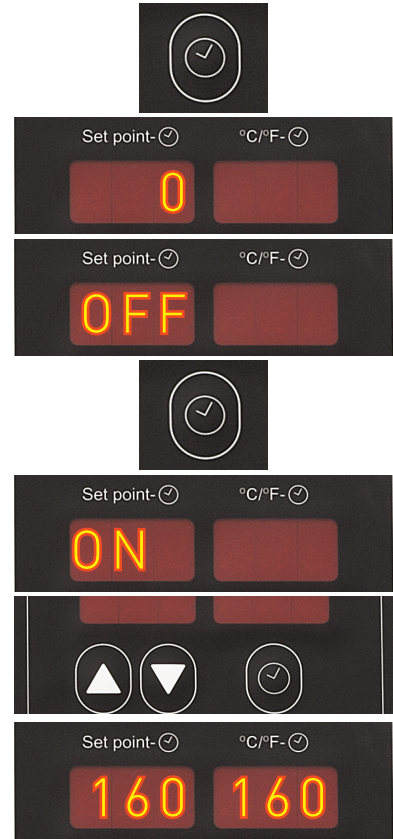

Programming the activation/deactivation of the equipment's standby function

An activation and deactivation time can be set for each day of the week, from Monday (1) to Sunday (7).

Time is expressed in increments of 15 minutes, starting with 10.0 (10 hours 0 minutes), then 10.1 (10 hours 15 minutes), 10.2 (10 hours 30 minutes) and 10.3 (10 hours 45 minutes).

1. Press the button with the clock symbol.

'0' will appear on the display indicating the program for setting the current day and time.

2. Press the standby function button.

'1' appears indicating the first day in the standby function program.

[Since the current date and time are the same for both programs, a '0' does not appear in this menu].

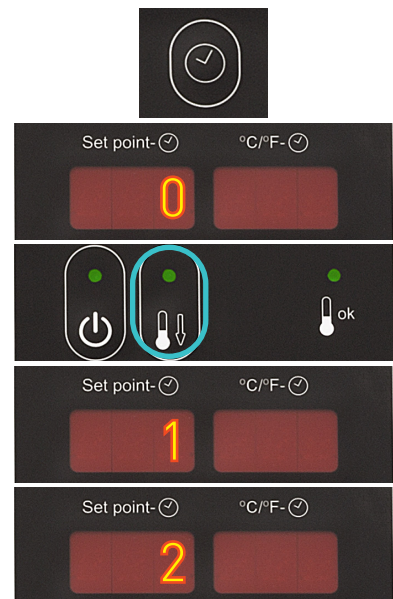

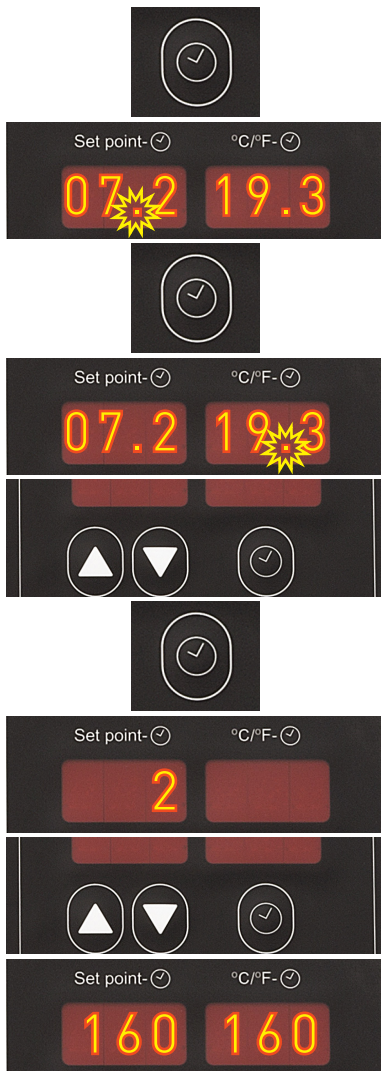

3. Use the up-down button under the display to select the value for the desired day of the week, Monday (1) to Sunday (7).

4. Press the button with the clock symbol again.

Two times will appear, one in each display. The display on the left shows the start time while the display on the right shows the end time.

5. The flashing dot on the start time display indicates that this value can be changed.

Use the up-down arrows under the display to select the desired value.

6. Press the button with the clock symbol again.

The dot then appears on the end time display.

7. Use the up-down arrows under the display to select the desired value.

8. Press the button with the clock symbol again.

The selected program appears once again. Use the up-down button under the display to select other programs.

9. Press any of the up-down component selection buttons to exit this program and return to the tank temperature display.

The green LED next to the “under maintenance” button will always blink provided that an activation time has been set for the equipment standby function for the current day.

Disabling the equipment standby function program

The programmed equipment standby function can be disabled without having to cancel the daily programming. In this way the programmed data is saved but the programming has no effect on the equipment.

1. Press the button with the clock symbol.

'0' will appear on the display indicating the program for setting the current day and time.

2. Press the standby function button.

'1' appears indicating the first day in the standby function program.

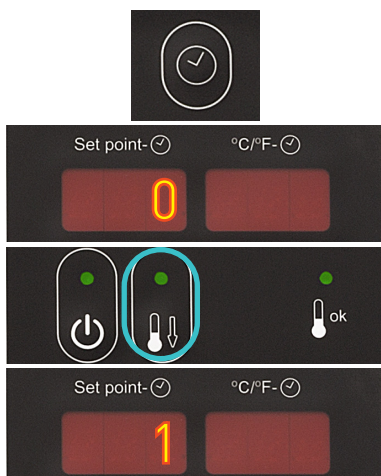

- Use the up-down arrow under the display to skip past the selection for the last day of the week (7).

'ON/OFF' will be displayed depending on the current status.

- Press the button with the clock symbol again.

The status will alternate each time you press the button.

- Press any of the up-down component selection buttons to exit this program and return to the tank temperature display.



Special function buttons

The simple programming of the B4 VS melters means that the special function buttons are only used for the standby function.

This manual function allows you to alternate between operating mode and standby mode. Using the standby function during periods of melter inactivity helps save energy and allows the heated components to return quickly to their set point temperature when you return to operating mode.

When the standby function is activated, the set point temperature for all the heated components drops to a certain value based on the programmed parameter (see 'Programming the melter parameters'). For example, if the tank set point temperature is 160°C and the standby function is set to 30 (30%), when the standby function button is pressed, the tank set point temperature will drop to 112°C (70% of 160°C).

The three systems for activating the standby function in the B4 VS melters have the following priority protocols:

- 1° Manual standby function button.
- 2° Standby function external signal.
- 3° Standby function activation/deactivation program.

Therefore, if the function is activated using any of the three systems, it can always be deactivated using the manual button. However, if the function is activated using the manual button it cannot be deactivated by either of the other two systems. The weekly programming cannot deactivate the function if it has been activated via any of the other two systems.

The following criteria is suggested for using the standby function:

- If the period of inactivity is less than 1 hour, leave the melter to heat as normal.
- If the period of inactivity is more than 1 hour but less than 2 hours, use the standby function.
- If the period of inactivity is more than 2 hours, turn off the equipment.

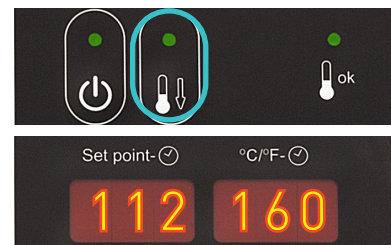

However, take into consideration that PUR adhesive undergoes moisture curing and deteriorates easily at high temperatures and therefore the more time the equipment is left on without pumping, regardless of whether it is left to heat as normal or is in standby mode, the greater the possibility that the adhesive will deteriorate.



Pump start-up

The gear pump is connected and disconnected using the switch on the pump control card placed on the front part of the equipment, provided that the start signal on the control board has been activated.

The motor can be started from an external contact, for example, using the trigger on a manual applicator, when this contact is connected to the rear round connector next to the hose connection (optional applicator switch).

In this way, the motor is activated while the external contact remains pressed down.

Pumping control

Starting up the pump control card

The pump control card (hereinafter also control card), features an ON-OFF button that allows us to turn off the displays and LEDs (leaving on only the 24 Vdc power supply LED)

The control card will turn off automatically depending on the status of pumping permission input:

- Whenever the pumping permission input is deactivated, the interface will be turned off and the control will be inoperative, unless turned on with the control card ON-OFF button.
- Should the 24 Vdc power supply to the control card be lost, on recovering the power supply the control card will remain turned off until pumping permission input is activated. If on recovering the power supply the pumping permission input is activated, it will turn on directly.
- If the power supply is available and pumping permission has not been received and the control card be turned off it must be turned on with the control card ON-OFF button.

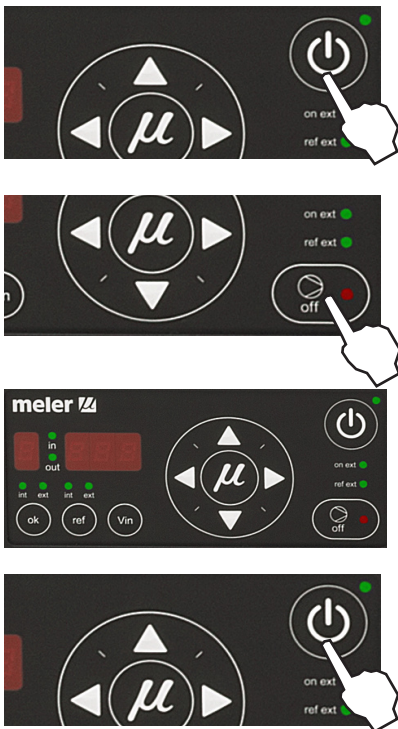

Pumping safety measures

To prevent the equipment from starting up unexpectedly, the control panel features by default a safety option that prevents pumping from commencing until enabled by pressing the ON-OFF button on the control card. This function may be disabled in the 'User configuration menu'.

For the pumping control to allow the pump to operate, the pumping ON-OFF button must be pressed, leaving it enabled (the red LED on the pumping ON-OFF button will turn off). When enabled, the control card will allow pumping as soon as all the required conditions are recovered, including pumping permission.

When pumping safety is enabled:

- In the event of loss of 24 Vdc power supply or the control panel is turned off with the control card ON-OFF button, the control will start up with pumping disabled (red ON-OFF button LED is illuminated) on recovering the power supply or turning the control card on, and prevent pump operation even if the pumping permission input is closed again, until the pumping ON-OFF button is pressed and the red LED turns off.
- Whenever the pumping permission input is deactivated, the control disables pumping (red ON-OFF button LED is illuminated) and prevents the operation of the pump even if the pumping permission input is closed again, until the pumping ON-OFF button is pressed and the red LED turns off.
- Whenever an error occurs, the control disables pumping (red ON-OFF button LED is illuminated) and prevents the operation of the pump until the error is reset, the pumping ON-OFF button is pressed again and the red LED turns off.

When pumping safety is disabled:

- In the event of loss of 24 Vdc power supply or the control is turned off with the control card ON-OFF button, on recovering the power supply or turning on the control card the control maintains the enabled status of the pumping ON-OFF button (if this was at the position ON, the unit will start up in ON and if it was at the position OFF it will start up in OFF).
- Whenever pumping permission input is deactivated, the pumping control stops the pumping operation, but does not disable it (red ON-OFF button LED turned off) and will allow pumping operation as soon as the pumping permission input is closed again.
- Whenever an error occurs, the pumping control stops the pumping operation, but does not disable it (red ON-OFF button LED turned off) and will allow pumping operation.

To deactivate pump safety see the section 'User configuration menu', paragraph 5.

Password security

If the option selected in the password security configuration is '1', security enabled, only the control card ON/OFF and pumping ON/OFF buttons will be operational. While this security option is programmed, in order to avoid the need to turn off and restart the machine to return to the 'User configuration





menu', on pressing any key (except the control card ON/OFF and pumping ON/OFF buttons) a password will be required. When the password is entered correctly, the control card can be left operational by setting it to '0'. When using this method to access the control card security configuration options, i.e., when the password has been entered, the buttons on the control card are temporarily unprotected until one minute has elapsed during which no buttons are pressed or until any key is pressed and the control panel resumes its protected status.

Whenever you are requested to enter a security password, the message P00 will appear on the displays. With the up/down arrow keys, select the 3-digit number that is your security password; as soon as the correct value for the programmed password is selected, press the right arrow key, if the password is correct, it will allow access to the selected field. The right arrow key will validate the password, provided it is the correct one; if it not the correct one, the message P00 will reappear on the screen and the process will recommence.

By default, the password is set to '000'.

LED indicators

Described below are the LED indicators on the pump control card to identify the status of the equipment:

- 1. Control card ON/OFF LED:** when the external 24 Vdc power supply is present, this LED will always be illuminated; with no power supply, it will be turned off. This LED is green in colour.
- 2. Pumping ON/OFF LED:** when pumping is enabled, this LED will be turned off, and will be illuminated when pumping is disabled. This LED is in colour.
- 3. Int and ext (ok) LEDs:** when the equipment is operating in Internal start-stop (ok) mode, the 'int' LED will be illuminated and the 'ext' LED will be turned off. When the equipment is operating in external start-stop (ok) mode, the 'ext' LED will be illuminated. And the 'int' LED will be turned off. These can never be both on or both off at the same time. These LEDs are green in colour.
- 4. Int and ext (ref) LEDs:** when the equipment is operating in internal reference mode, the 'int' LED will be illuminated and the 'ext' LED turned off. When the equipment is operating in external reference mode, the 'ext' LED will be illuminated and the 'int' LED will be turned off. These can never be both on or both off at the same time. These LEDs are green in colour.



5. Ext on LED: when the equipment is operating in external start-stop (OK) mode, and the external permission contact is closed, this LED will be illuminated; if the external contact is open, this LED is turned off. This LED is green in colour.

6. Ext ref LED: when operating in external reference mode and the external reference voltage is other than zero, this LED will be illuminated. When the external reference voltage is zero, this LED will be turned off. This LED is green in colour.

7. In/Out LED: when operating in external set point reference mode, these LEDs will be activated and deactivated as the speed ramp options are programmed. These LEDs are green in colour.

Modes of operation

First of all, we must bear in mind that when password security is enabled and the control card is not manipulated during one minute, it is blocked and you need to enter the password. To prevent this from happening, password security may be disabled following the steps in the section 'Password security'.

Mode of operation with internal pumping control and internal speed control

In this working mode the user has full control of the start/stop function and speed pump set.

Follow the steps below to use this operating mode:

1. Press the ON/OFF button to light up the control card.
2. Select 'ok' in the position 'int' and 'ref' in the position 'int'.

To activate the start-up status, all of the following conditions must be met:

- That the input for pumping permission (E4) at central control is activated, as pumping is not possible unless the equipment temperature is OK.
- That pumping is enabled with the pumping ON-OFF button (red LED is turned off).
- That the failure input is not activated (E5), in which case starting the pump would be impossible. In case of the pump be operating and this input is activated, pumping will cease immediately.

If a speed has been previously set, this value will be shown on the display and the pump will start to rotate at the speed indicated provided that all prior conditions are met. Otherwise:

3. Using the up/down arrows, select the rotation speed and/or wait for pumping permission to be enabled (red LED is turned off).

At this moment, the pump will start to rotate at the speed indicated on the display.

4. Adjust the rotation speed to the value required for the application. The selected value is set pressing the right arrow key after blinking three times.

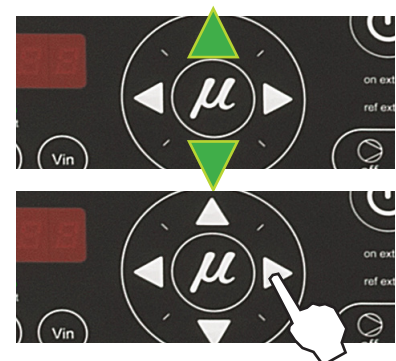

The pump will stop whenever:

- The control card is disabled with its ON/OFF button.
- The pumping ON-OFF button is pressed (red LED is illuminated).
- When a variator error signal is activated (E5).
- When the MAXIMUM RPM ALARM TIME appears.
- When the MINIMUM RPM ALARM TIME appears.

The maximum full scale for admissible revolutions is 100 (we recommend working at speeds of not less than 10 rpm and not greater than 80 rpm).

This full scale can be adjusted by reducing this value in percentage terms. To make adjustments consult the 'User configuration menu', '1. MAXIMUM RPM'.

Mode of operation with internal pumping control and external speed control

In this operating mode, pumping is controlled from the equipment and speed is controlled by a 0-10 V external signal from the main machine.

Follow the steps below to use this operating mode:

1. Press the ON/OFF button to light up the control card.
2. Select 'ok' in the position 'int' and 'ref' in the position 'ext'. The 'ref ext' LED will illuminate when voltage is received.

To activate the start-up status, all of the following conditions must be met:

- That the signal from the main machine reaches input E2 and its value is not 0.
- That the input for pumping permission (E4) at central control is activated, as pumping is not possible unless the equipment temperature is OK.
- That pumping is enabled with the pumping ON-OFF button (red LED is turned off).
- That the failure input is not activated (E5), in which case starting the pump would be impossible. In case of the pump be operating and this input is activated, pumping will cease immediately.

The system will wait for the speed signal from the main machine. When the signal has been received, if a speed has been previously set it will appear on the display and the pump will begin to rotate at the indicated speed.

If not, the rotation speed must be adjusted to the value required for the application. There are three ways to do this:

1. Change the voltage applied from the main machine.
2. Change the full scale [see section '1. MAXIMUM RPM' in the 'User configuration menu'].



3. Modify the speed ramp (see section 'Configuring speed ramp').

Keeping the 'Vin' key pressed will show the voltage sent by the main machine.

The pump will stop whenever:

- The control card is disabled with its ON/OFF button.
- The pumping ON-OFF button is pressed (red LED is illuminated).
- When the MAXIMUM RPM ALARM TIME appears.
- When the MINIMUM RPM ALARM TIME appears.
- When the voltage signal from the main machine is zero.

The maximum full scale for admissible revolutions is 100 (we recommend working at speeds of not less than 10 rpm and not greater than 80 rpm).

The full scale can be adjusted by reducing this value in percentage terms. To make adjustments consult the 'User configuration menu', '1. MAXIMUM RPM'.

Mode of operation with external pumping control and internal speed control

In this operating mode, pumping is controlled from the main machine while speed is controlled from the equipment.

Follow the steps below to use this operating mode:

1. Press the ON/OFF button to light up the control card.
2. Select 'ok' in the position 'ext' and 'ref' in the position 'int'. The 'on ext' LED will be illuminated when temperature is ok.

To activate the start-up status, all of the following conditions must be met:

- That the input for pumping permission (E4) at central control is activated, as pumping is not possible unless the equipment temperature is OK.
- That pumping is enabled with the pumping ON-OFF button (red LED is turned off).
- If the external 'ok' mode (start-stop) is selected, the external 'ok' input (E3) must be activated.
- That the failure input is not activated (E5), in which case starting the pump would be impossible. In case of the pump be operating and this input is activated, pumping will cease immediately.

The system will wait for the pumping control signal from the main machine. If a speed has been previously set, this value will be shown on the display and the pump will start to rotate at the speed indicated provided that all prior conditions are met. Otherwise:

3. Using the up/down arrows, select the rotation speed and/or wait for pumping permission to be enabled (red LED is turned off).



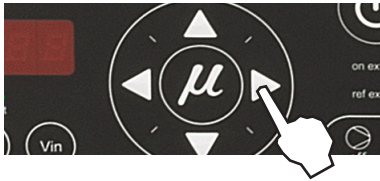

At this moment, the pump will start to rotate at the speed indicated on the display.

- Adjust the rotation speed to the value required for the application. The selected value is set pressing the right arrow key after blinking three times.

The pump will stop whenever:

- The control card is disabled with its ON/OFF button.
- The pumping ON-OFF button is pressed (red LED is illuminated).
- When the pumping permission input is deactivated (E3).
- When a variator error signal is activated (E5).
- When the MAXIMUM RPM ALARM TIME appears.
- When the MINIMUM RPM ALARM TIME appears.

The maximum full scale for admissible revolutions is 100 (we recommend working at speeds of not less than 10 rpm and not greater than 80 rpm).

The full scale can be adjusted by reducing this value in percentage terms. To make adjustments consult the 'User configuration menu', '1. MAXIMUM RPM'.

Mode of operation with external pumping control and external speed control

In this working mode, both pumping and speed are controlled from the main machine.

Follow the steps below to use this operating mode:

- Press the ON/OFF button to light up the control card.
- Select 'ok' in the position 'ext' and 'ref' in the position 'ext'. The 'on ext' and 'ref ext' LEDs will be illuminated when temperature is ok and voltage is received.



To activate the start-up status, all of the following conditions must be met:

- That the signal from the main machine reaches input E2 and its value is not 0.
- That the input for pumping permission (E4) at central control is activated, as pumping is not possible unless the equipment temperature is OK.
- That pumping is enabled with the pumping ON-OFF button (red LED is turned off).
- If the external 'ok' mode (start-stop) is selected, the external 'ok' input (E3) must be activated.
- That the field MAXIMUM RPM is not set to zero (this field is available on the control card 'User configuration menu').

- That the failure input is not activated (E5), in which case starting the pump would be impossible. In case of the pump be operating and this input is activated, pumping will cease immediately.

The system will wait for the main machine to send the pumping activation and rotation speed signals. When this signal has been received, if a speed has been previously set, this value will appear on the display and the pump will start to rotate at the indicated speed.

If not, the rotation speed must be adjusted to the value required for the application. There are three ways to do this:

1. Change the voltage applied from the main machine.
2. Change the full scale (see section '1. MAXIMUM RPM' in the 'User configuration menu').
3. Modify the speed ramp (see section 'Configuring speed ramp').

Keeping the 'Vin' key pressed will show the voltage sent by the main machine.

The pump will stop whenever:

- The control card is disabled with its ON/OFF button.
- The pumping ON-OFF button is pressed (red LED is illuminated).
- When the pumping permission input is deactivated (E3).
- When a variator error signal is activated (E5).
- When the MAXIMUM RPM ALARM TIME appears.
- When the MINIMUM RPM ALARM TIME appears.
- When the voltage signal from the main machine is zero.

The maximum full scale for admissible revolutions is 100 (we recommend working at speeds of not less than 10 rpm and not greater than 80 rpm).

The full scale can be adjusted by reducing this value in percentage terms. To make adjustments consult the 'User configuration menu', '1. MAXIMUM RPM'.

The pump control card is designed with certain parameters programmed at Meler that can be modified if necessary to meet your requirements. Modifications may be made through the user configuration and programming speed ramp menus.

User configuration menu

To open this menu, press simultaneously the left arrow key, the right arrow key, and ON/OFF button of the pump control card.

If the security password is enabled, the security password must be entered to access this menu. By default, all the equipments is set to 000 that the user may change at any time. If the security password is not enabled, direct access will be given to the following menu:

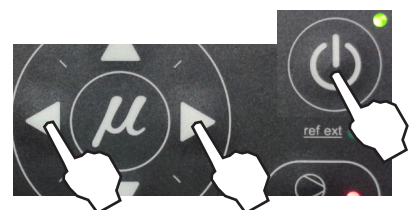

- 1. MAXIMUM RPM ALARM:** this will be a value set between 0 and the value programmed in the MAXIMUM RPM field. If we do not wish this alarm to be operational it must be programmed to the MAXIMUM RPM value. The default value is 100 (consequently, alarm not operational).
- 2. MAXIMUM RPM ALARM TIME:** this will be a period programmed between 0 and 999 (in seconds). In the event that the output RPM exceed the value programmed for MAXIMUM RPM ALARM during the period established in this field, MAXIMUM RPM error will be activated (the pump will stop, and an error message will be displayed). By default, this value is 30 seconds.
- 3. MINIMUM RPM ALARM:** this will be a value set between 0 and the value programmed in the MAXIMUM RPM field. This value may never be greater than the value programmed in the MAXIMUM RPM ALARM field. If the value programmed is '0' the error function will be disabled. By default, this value is 0 (disabled).
- 4. MINIMUM RPM ALARM TIME:** this will be a period programmed between 0 and 999 (in seconds). In the event that the output RPM are less than the programmed value for MINIMUM RPM ALARM during the period established in this field, MINIMUM RPM error will be activated (the pump will stop, and an error message will be displayed). By default, this value is 30 seconds,
- 5. PUMPING SAFETY FUNCTION:** this consists of an editable field (0 enabled – 1 disabled). By default, this is set to '0' (enabled).
- 6. SECURITY PASSWORD:** The security password may be changed in an editable field. The current password must be entered to access and edit the field. (See the section 'Password security' in this chapter).
- 7. ENABLING THE SECURITY PASSWORD:** this consists of an editable field (0 disabled, 1 enabled). The current password must be entered to access and edit the field. By default, this is set to '0'. (See the section 'Password security' in this chapter).

Displaying alarms and reset function

Maximum rpm alarm

This alarm will be triggered when the motor rotates at a speed exceeding the MAXIMUM RPM ALARM value for the period established in the MAXIMUM RPM ALARM TIME field.

- When this alarm is triggered, an 'E.H.' error is shown on the control card.
- To reset this error, you must turn off and start up the control card with its ON/OFF button.

Minimum rpm alarm

This alarm will be triggered when the motor rotates at a speed that is below the MINIMUM RPM ALARM for the period established in the MINIMUM RPM ALARM TIME field.

- When this alarm is triggered, an 'E.L.' error is shown on the control card.

- To reset this error, you must turn off and start up the control card with its ON/OFF button.

Variator alarm

This alarm is triggered when the control card input is activated by a variator error signal.

- When this alarm is triggered, an 'E.U.' error is shown on the control card.
- The error message will be maintained while the variator error input (E5) remains active. As soon as this input is deactivated the alarm will be reset.

Note: In the event that a RPM alarm and a variator ERROR alarm should coincide, alternating messages will appear on the display.



Configuring speed ramp

For equipment operating in external reference, the display will show the current pump rotation set point (input reference conversion as per the full scale and the conversion table).

The conversion table may be programmed with up to 5 points (input voltage (V) and output speed (RPM)).

By default the table is programmed (0 V = 0 rpm and 10 V = 100 rpm):

	Vin	RPMs Out
punto 1	0,0	0
punto 2	10,0	100
punto 3	10,0	100
punto 4	10,0	100
punto 5	10,0	100

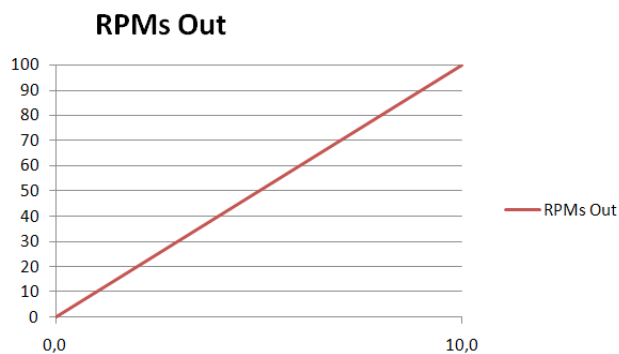

Notes on the editable values in the conversion table:

- The value for voltage must always be shown to one decimal place.
- Point 1 is the starting point for the speed ramp, and therefore the voltage will always be 0, while the value for output RPM is editable.
- The possible values for each point must be equal to or greater than the value corresponding to the previous point.
- Point 5 is the final point for the speed ramp, and therefore the voltage will always be 10, while the value for output RPM is editable.
- It is not necessary to program the value for MAXIMUM RPM in this table.

- If, at any point, the maximum value for Vin = 10 V is entered, the corresponding values for Vin and RPM at higher points will be automatically updated according to the value for this point.
- If, at any point, the maximum value is entered, that is, RPM = MAXIMUM RPM, the corresponding values for RPM at higher points will be automatically updated to MAXIMUM RPM.

	Vin	RPMs Out
punto 1	0.0	0
punto 2	2.5	25
punto 3	10.0	80
punto 4	10.0	80
punto 5	10.0	80

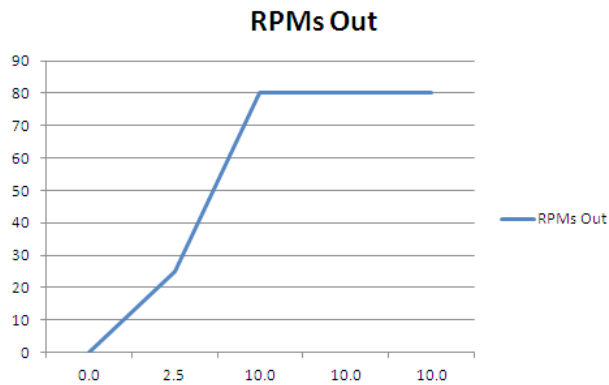

Programming speed ramp

To access this menu and program the different points corresponding to the voltage-speed ratio, you must select external reference ('ref ext' LED is illuminated) and press the right arrow key. Then the following message is displayed:



The IN LED to the position **ON** and the OUT LED to the position **OFF, 1 000, NOT EDITABLE**; press the right arrow to go to the next point:



The IN LED to the position **OFF** and the OUT LED to the position **ON, 1 XXX**, which means that the output speed is being programmed for point 1 (when the input voltage is 0 V); with the up/down arrow keys the value may be modified, within a range from 000 to MAXIMUM RPM; press the right arrow key to go to the next point:

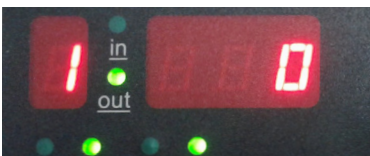

The IN LED to the position **ON** and the OUT LED to the position **OFF, 2 XXX**, which means that the input voltage value is being programmed for point 2; with the up/down arrow keys the value may be modified, within a range from 00.0 to 10.0 (to one decimal place); press the right arrow key to go to the next point:

The IN LED to the position **OFF** and the OUT LED to the position **ON, 2 XXX**, which means that the output speed value is being programmed for point 2; with the up/down arrow keys the value may be modified, within a range from 000 to MAXIMUM RPM; press the right arrow key to go to the next point:

The IN LED to the position **ON** and the OUT LED to the position **OFF, 3 XXX**, which means that the input voltage value is being programmed for point 3; with the up/down arrow keys the value may be modified, within a range from 00.0 to 10.0 (to one decimal place); press the right arrow key to go to the next point:

The IN LED to the position **OFF** and the OUT LED to the position **ON, 3 XXX**, which means that the output speed value is being programmed for point 3; with the up/down arrow keys the value may be modified, within a range from 000 to MAXIMUM RPM; press the right arrow key to go to the next point:

The IN LED to the position **ON** and the OUT LED to the position **OFF, 4 XXX**,

which means that the input voltage value is being programmed for point 4; with the up/down arrow keys the value may be modified, within a range from 00.0 to 10.0 (to one decimal place); press the right arrow key to go to the next point:

The IN LED to the position **OFF** and the OUT LED to the position **ON, 4 XXX**, which means that the output speed value is being programmed for point 4; with the up/down arrow keys the value may be modified, within a range from 000 to MAXIMUM RPM; press the right arrow key to go to the next point:

The IN LED to the position **ON** and the OUT LED to the position **OFF, 5 100**, NOT EDITABLE; press the right arrow key to go to the following message:

The IN LED to the position **OFF** and the OUT LED to the position **ON, 5 XXX**, which means that the speed value is being programmed for point 5; with the up/down arrow keys the value may be modified, within a range from 000 to MAXIMUM RPM; press the right arrow key to exit the menu.

Press the right arrow key to return to the menu, and the initial message is displayed: The IN LED to the position **ON** and the OUT LED to the position **ON, 1 000**.

To exit this menu, the equipment must be turned off and started up using the control card ON/OFF button.

To save the newly entered data, use the right and left arrow keys to go forward or backward in the menu: if any field has been modified using the up/down arrow keys, and the ON/ OFF button is pressed to turn the equipment off, the data will not be saved.

Current Vin voltage display

Whenever the Vin key is held pressed, the three digits on the right will show the input voltage reading to one decimal point.

If the values for any point in the speed ramp table is being edited, and the Vin key is held pressed for 3 seconds, the voltage value which is operating at this time it will be copied to that value on the table.

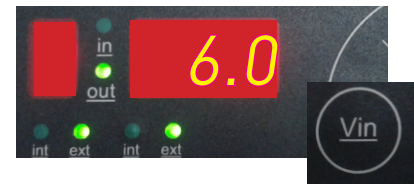

Regulating the bypass valve

The pump system with gear pump supplies a constant flow of adhesive based on the pump rotation speed.

In this type of system, the pressure generated by the pump is a result of the retentions produced in the circuit (length and diameter of the hose, elbows in the couplings, diameter of nozzle outputs, etc.) and the adhesive itself (viscosity).

For safety reasons, this pressure must be discharged when the circuit exceeds the working value -normally with the circuit closed and the pump activated- which requires the use of a discharge or bypass valve.

This valve may be a manual adjustment valve, using a threaded allen head screw, or with pneumatic control, using a pressure regulator and a pressure gauge. In the latter case, the adhesive circuit pressure has a 1:13 ratio to the pressure displayed on the pressure gauge.

Adjusting the manual valve

Follow the steps below to set the pressure using this type of valve (approximate):

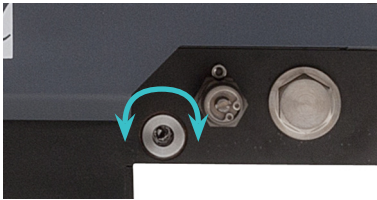

1. Screw the spindle in as far as possible in the clockwise direction. In this position, the maximum pressure is 81,5 kg/cm² (80 bar).
2. Gradually loosen anti-clockwise until the desired pressure is reached. Each millimetre the spindle sticks out corresponds -approximately- to a reduction of 9 kg/cm² (8,82 bar).

By default, the equipment is calibrated with a hydraulic pressure of approximately 40 bar.

Pneumatic valve control

To adjust the pressure with this valve model, follow these steps:

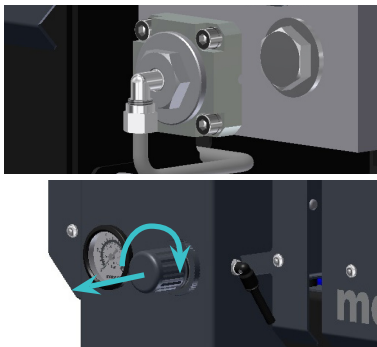

1. Unlock the pressure regulator control by pulling on it gently.
2. Turn it clockwise to increase the pressure. This will be seen reflected on the pressure gauge located next to it.

Warning: Do not exceed 6 bar of pressure. This corresponds to 80 bar on the hydraulic circuit.

Turning off the melter

If it is necessary to disconnect the melter:

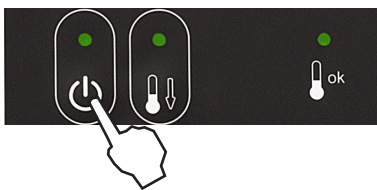

1. Press the control card ON/OFF button to switch off the card.
2. Disconnect the equipment's power switch located on the side, next to the power supply input.
3. Disconnect the applicators' pneumatic power supply and the electric supply to the control programmer if applicable.

5. MAINTENANCE

Warning: The melter equipment is equipped with current technology, but has certain foreseeable risks. Therefore, only allow qualified personnel with enough training and experience to operate install or repair this equipment.



The following table briefly summarizes the indications for adequate melter equipment maintenance. Always read the corresponding section carefully.

Operation	Frecuency	Refer to
External cleaning	Daily	Equipment cleaning
Despresurización del sistema	Before performing maintenance tasks and repairing the hydraulic system	Depressurizing the system
Emptying and cleaning the tank	- When burnt adhesive is present - With each adhesive change	Tank cleaning
Filter cleaning or changing	- As needed (once a year minimum) - With each adhesive change	Filter maintenance
Check for pump leaks	Depending on the hours of operation and the temperature and speed parameters(min. once per month)	Pump maintenance
Check the lubrication (motor and gear)	Depending on the temperature and conditions of use (max. 8000 hours)	Motor gear maintenance
Check thermostat operating	- Checking while working	Safety thermostat
Equipment change	- Equipment change or repair	Detaching equipment from base

If the equipment does not work or works incorrectly, called to your Meler Technical Assistance Service or to the Main Office.

External cleaning

To continue to take advantage of the melters benefits and to ensure the perfect mobility of its components, it is necessary to keep all its parts clean, especially the ventilation grates on the of the machine.

Warning: Risk of electric shock. Carelessness may result in injury or death. Clean the exterior using a cloth moistened with water. Do not use flammable liquids or solvents.



External cleaning:

- Use cleaning products compatible with painted surfaces.
- Apply the cleaning product with a soft cloth.
- Do not use sharp tools or scrapers with sharp edges.



Removing the rear covers from the tank:

1. Disconnect the melter equipment using the circuit breaker.
2. Disconnect the compressed air from the equipment intake (in case of air drying system or pneumatic bypass valve).
3. Remove the four screws fastening the tank cover.
4. Remove the cover sliding it in the direction shown in the figure.
5. To reposition the covers, follow steps 1 to 4 in reverse order.

Removing the control box cover:



1. Disconnect the melter using the circuit breaker.
2. Remove the four screws fastening the cover to the equipment's control box.
3. Remove the cover, sliding it upwards in the direction shown in the figure.
4. To replace the cover follow steps 1 to 3 in reverse order.

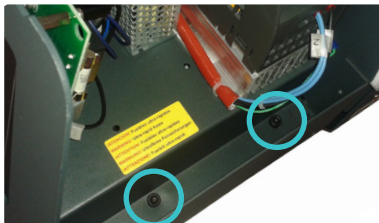

Opening the control box to access the components inside:

1. Perform steps 1 to 3 to remove the control box cover.
2. Remove the two screws fastening the control panel to the frame of the melter.
3. Tilt the control panel to the left.
4. Follow steps 1 to 3 in reverse order to close the control panel.

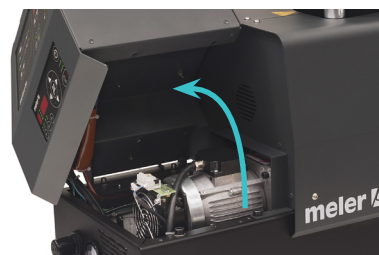

System depressurisation

The B4 VS melter is a pressurised application system with the corresponding risks that such a system entails. This equipment includes a safety valve (bypass valve) which limits the maximum pressure in the system, particularly during continuous pumping with closed application applicators.

However, in this last case, even with the motor stopped, residual pressure may remain in the circuit. This should be taken into account when carrying out any work on the hydraulic circuit.

Before disconnecting any hydraulic component or opening any distributor outlet, the following steps must be performed:

1. Disconnect the equipment's power switch located on the side, next to the power supply input.
2. Manually purge (or using the corresponding programmer control) the applicator used.
3. Open the purge valve (in case of the equipment has one), located on the distributor next to the filter turning it anti-clockwise. To do so, use a slotted screwdriver. When the adhesive exits without pressure, close the valve by turning it clockwise.

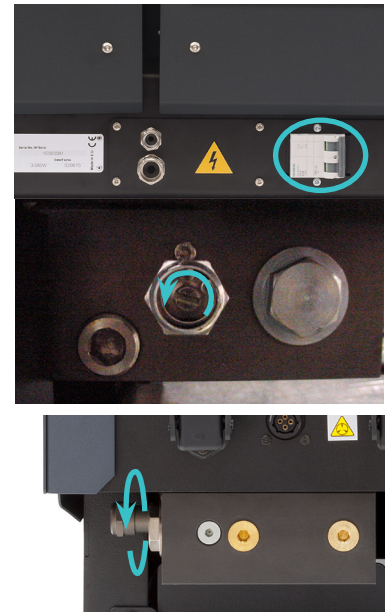

Cleaning the tank

Both the cylindrical hopper and hot-melt tank will need cleaning occasionally to maintain their melting and anti-adherence properties. The tank interior is covered in PTFE and sufficiently slanted to help the unloading of the hot-melt adhesive and prevent it from remaining inside which would result in burning.

Also, when adhesives are mixed, reactions may occur between them, causing degeneration and problems unloading to the pump.

It is therefore recommended that the tank is cleaned each time:

- A different hot-melt adhesive is used.
- Too much carbon deposit is generated inside.

Changing adhesive type

1. Use up as much of the adhesive as possible.

If you need to unload the adhesive before it has been used up, follow the instructions in the section 'Emptying the tank'.

2. Clean the remains of the hot-melt adhesive from inside the tank.

Warning: Use the appropriate protective equipment for high temperatures.



3. Add the appropriate type and quantity of the new adhesive, wait for it to melt and pump at least one full tank through the system (hose and applicator).

Cleaning burnt adhesive

1. Empty the tank directly (see the section 'Emptying the tank') to prevent the burnt material from passing through the pump circuit.



- Clean the adhesive remains and burnt material inside the tank. Do not use sharp objects that might damage the inside coating.

Warning: Use appropriate protective equipment for high temperatures.

- Add the appropriate type and quantity of adhesive and wait for it to melt.
- Remove the filter cartridge and clean it, if necessary (see the section 'Filter maintenance').
- Reassemble the filter without the cartridge.
- Pump a minimum of one tank through the distributor output.
- Remove the filter and attach it to the corresponding cartridge. Reinstall it in the distributor.
- Refill the tank with adhesive, wait for it to melt and continue working as usual.



Warning: Whenever you handle the filter or any other element subject to pressure, you must always perform a system depressurization first (see the corresponding section)

Emptying the tank

During normal maintenance work it is recommended, and sometimes necessary, to empty the tank.

To do so, follow the instructions below:

- Maintain the melter unit at the working temperature.
- Place a container under the purge valve to collect the adhesive.

Note: in case of pneumatic bypass valve, purge manually using the applicator used.

- Open the purge valve anti-clockwise using a screwdriver.
- Set the pump to maximum speed.
- After emptying the tank, close the purge valve, remove the container and clean the valve output for future operations.

Warning: Use the appropriate protective equipment for high temperatures.



Filter maintenance

B4 VS melter equipment is equipped with a 100 mesh pump filter. The filter prevents impurities and burnt adhesive remains from being pushed out from the tank by the pump.

When the filter is removed from its housing, all the impurities remain inside so that the inside of the distributor stays perfectly clean. The filter can be cleaned or replaced with a new one.

No rule exists for determining when the filter should be changed. Several factors influence this decision:

- The type and purity of the adhesives used.
- The working temperatures of the adhesive.
- Adhesive consumption in relation to the time in the tank.
- Changes to the type of adhesive used.

In any case, we recommend that the filter is checked and cleaned at least every 1000 hours of operation (melter turned on).

Warning: Always wear protective gloves and safety glasses. Risk of burns.

To change the filter:

1. Depressurise the system.
2. Using a 22 mm wrench, unscrew the hexagonal filter cap turning left and remove it.
3. Unscrew the filter nut (1) and remove the mesh (2) from the filter body (3).
4. Depending on how dirty the mesh (2) is, clean or replace it, following any waste regulations in force.
5. Screw the nut (1) back in place and place the filter inside the distributor.
6. Replace the filter cap screw if damaged.
7. Screw the filter cap turning right and tighten as far as possible.
8. Continue to work as normal.

Warning: Use the appropriate protective equipment for high temperatures.

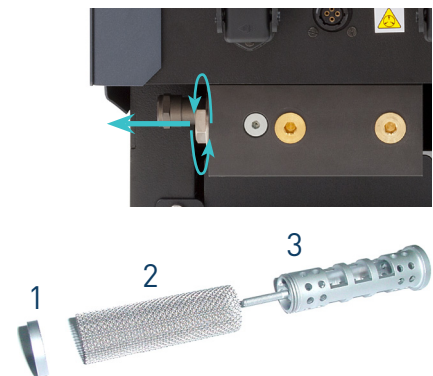
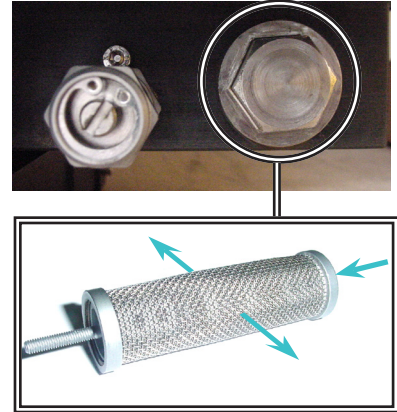

Pump maintenance

Leakage inspection

The pump is equipped with a gasket system in the shaft and gaskets in the seating pump to prevent adhesive leaks through it. Some adhesive can sometimes leak out and therefore the gasket system in the shaft or the gaskets in the seating pump must be changed. Before making any changes, make sure the position of the leak.

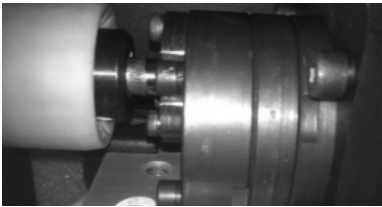

Warning: Change the gasket when the pump is hot.

Remove the shaft coupling from the pump. Remove the screws fastening the gasket. Replace the gasket system in the shaft or the gaskets in the seating pump and reassemble.

However, before making any changes and in case of doubt should check with the Technical Assistance Service of Meler.

Warning: Always wear protective gloves and safety glasses. Risk of burns.

Gear motor maintenance

Cleaning the motor fan

Regularly check the condition of the motor fan and its vent grid.

If dust has accumulated, blow gently with air to clean (remove the protective cover if necessary).

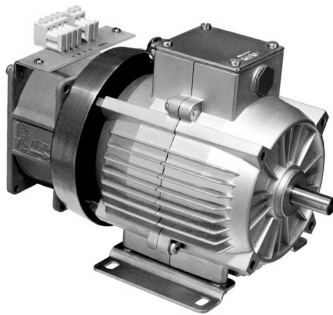

Checking the lubricant

The gears are delivered filled with synthetic grease for lubrication -free from external contamination- 'for life'. Room temperature 0 ÷ 40°C with peaks of up to -20°C and +50°C.

Only use lubricants recommended by the manufacturer. Other types of lubricants may cause premature wear or damage the gear.

Approximately 0.10 kg of lubricating grease fits into the gear model used.

Recommended lubricant

Grasa Kluber, Staburags NBU 12/300.

Safety Thermostat

If there is a deactivation of the thermostat, dismantle the tank casing with the cover and slide the electrical cabinet along. When you can see the thermostat, press the button indicated to reset it.

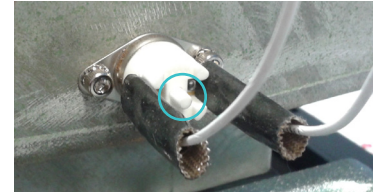

Removing the equipment from its base

For more thorough maintenance of the equipment, the melter needs to be removed from its location so that it can be handled with greater ease and accessibility.

To do this, remove it from its base as follows:

1. Disconnect the equipment from the mains using the power switch on the side.
2. Depressurise the system.
3. Disconnect the hoses connected to the distributor outputs both electrically and hydraulically.
4. Disconnect the input power supply and ground connection.
5. Remove the screws fastening the equipment to the base.
6. Raise the equipment upwards to remove from its base.

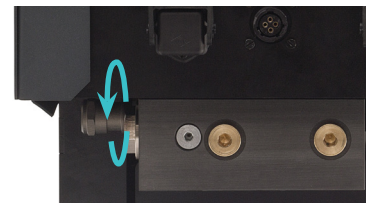

This page is intentionally left blank.

6. TECHNICAL CHARACTERISTICS

General

Tank volume	4 litres
Maximum pump flow rate (*)	between 1,2 and 15,6 Kg/hr with 2 cc/rev pump
Maximum melting rate (*)	6,0 kg/h
Number of pumps	1
Number of electrical outputs	2
Number of hydraulic outputs	2
Gear motor	three-phase 179W two-pole forced ventilation
Pump	2 cc/rev
Pump rotation speed	0-100 rpm (recommended 10-80 rpm continuously)
Maximum working pressure	80 bar max. (1160 psi)
	mechanical or pneumatic bypass valve (adjustable)
Total equipment output	3680W 16A
External functions	Temperature output ok
	External standby
	Starting up the motor
	Motor speed set point reference
	Failures output in pump control card
Options	Air-tight lid
	Activation pump mode by external switch
	Level control system
	Air drying system for PUR adhesives
	Automatic tank filling system
Electrical requirements	LN~ 230V 50Hz + PE / 16A
Room temperature	0 to 40°C
Temperature range	40 to 200°C (100 to 392°F)
Temperature control	RTD $\pm 0.5^{\circ}\text{C}$ ($\pm 1^{\circ}\text{F}$) Pt100 and Ni120
Dimensions	see diagram on following page
Weight	40 kg without load (approx)

(*) Under normal conditions

Dimensions

Melting unit

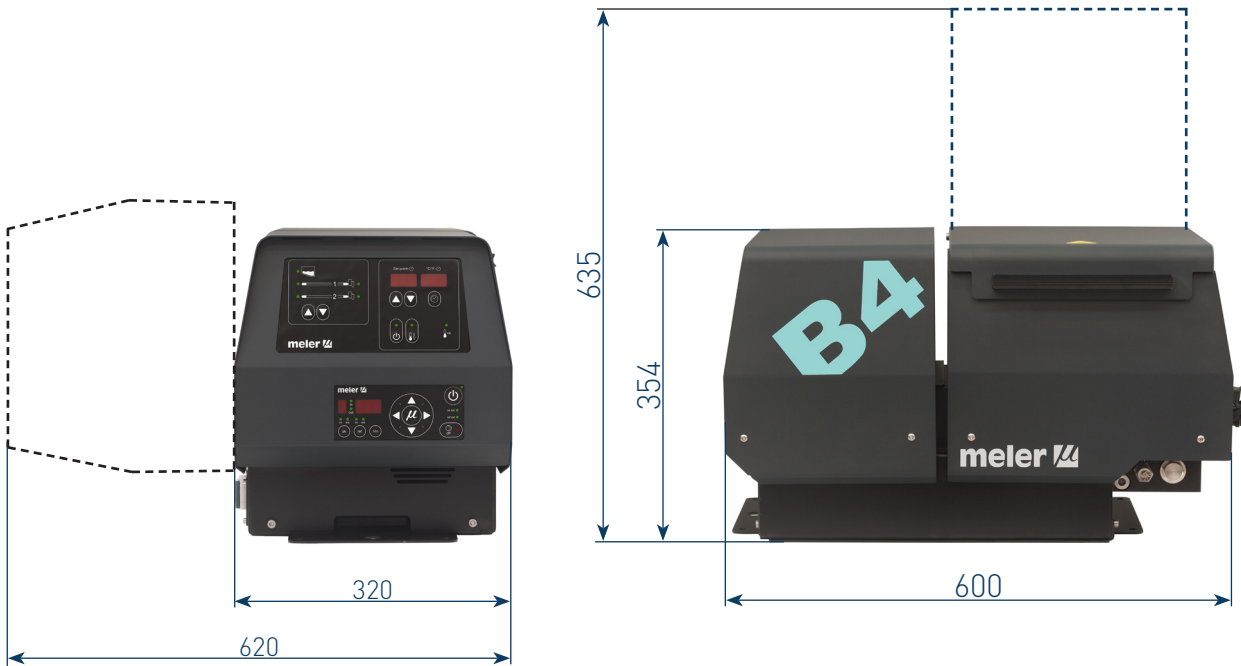

Base plate

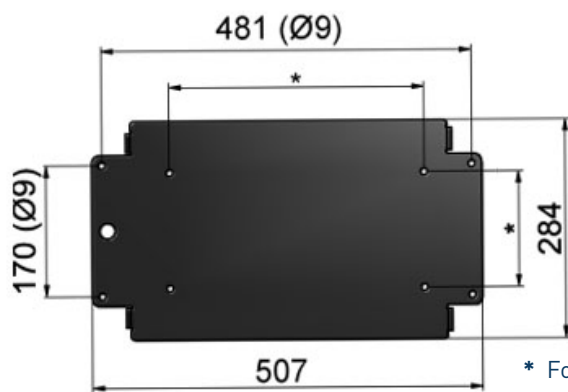

* For ML-240-ST series replacement.

Accessories

Level control system

The level of the hot-melt is done with an capacitive detector and the warning is through a light tower.

Air drying system for PUR adhesives

Polyurethane-based reactive adhesives, known as P.U.R. (reactive polyurethanes), require a completely dry environment before they can be applied, since when they come in contact with atmospheric humidity, they reticulate, hardening quickly.

The 'B4 VARIABLE SPEED' melting equipment ensures a dry environment thanks to the addition of an air-drying system to these models, which provides a level of dehumidification above 99.98%. This guarantees that the adhesive is preserved without premature reticulations inside the applicator unit. The installation of the electro-pneumatic control is a standard in all versions. You can choose if you want to order the air-dryer assembly (two filters and the dryer membrane) or not.

If not, you can use your own air-dryer system or another inert gas like nitrogen (N₂). Ask you adhesive supplier for more information.

Automatic tank filling system

Meler pellet loaders ensure a continuous level of adhesive inside the tanks of the melting units, eliminating the need for manual loading by the user.

Each time the tank detector detects a low level of adhesive, it sends a signal to the suction system, which transfers a load of pellets to the melting tank from the adhesive container (or directly from the bag it comes in).

This page is intentionally left blank.

7. ELECTRICAL DRAWINGS

This page is intentionally left blank.

8. PNEUMATIC DRAWINGS

Components list

Pneumatic by-pass valve control system (optional)

- 1 Pressure regulator 1-10 bar
- 2 Pressure gauge 0-10 bar
- 3 Pneumatic limit control valve

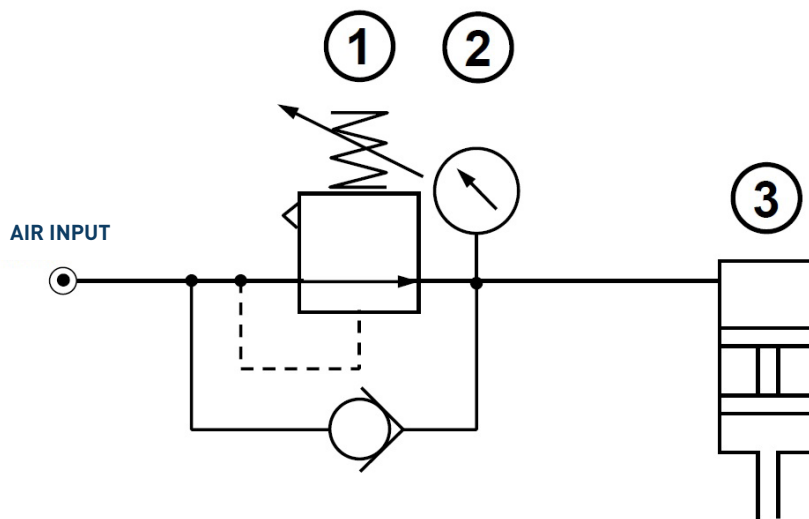

Air drying system (optional)

- 1 Filter- 1st stage
Solids/ Oil $5\mu < 1\text{ppm}$
- 2 Filter - 2nd stage
Solids/ Oil $0,01\mu < 0,01\text{ppm}$
- 3 Membrane dryer (Dry air 99,98%)
- 4 3/2 solenoid valve
- 5 Pressure regulator 1-10 bar
- 6 Pneumatic relief valve 0,5 bar
- 7 Pressure regulator 0.1- 0.7 bar
- 8 Pneumatic gauge 0-1.6 bar
- 9 Input pipe
- 10 2/2 output solenoid valve
- 11 Non-return valve 0,5 bar

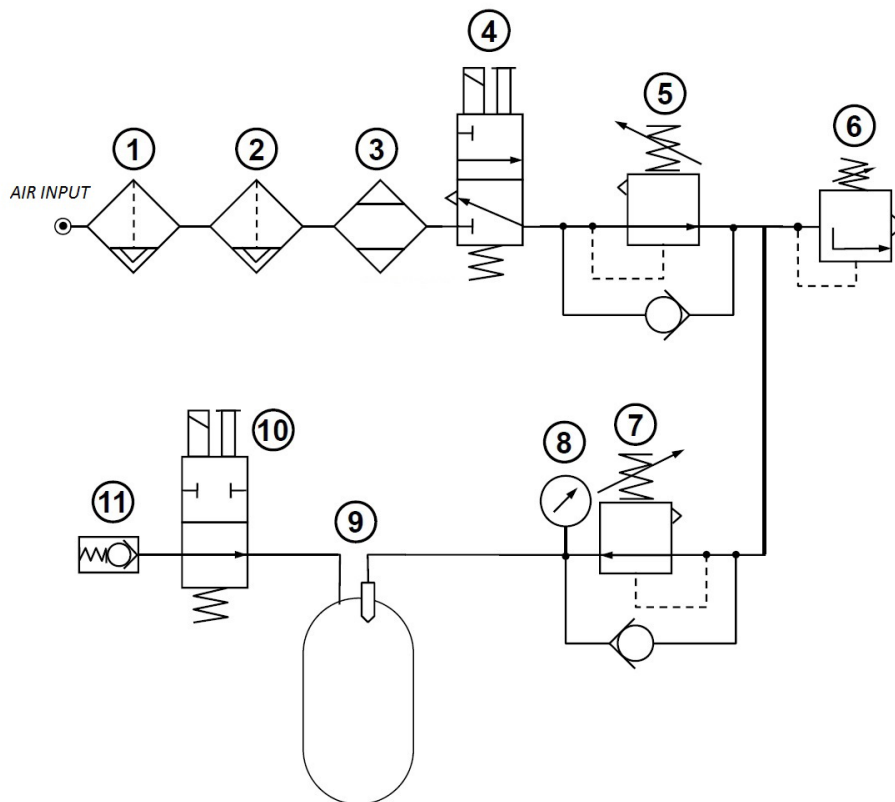

9. SPARE PART LIST

The most common spare parts list of the B4 VS adhesive melters is shown in this chapter to give you a quick and sure guideline to choose them.

The spare parts are listed by groups in a natural order as they are located on the units.

As a visual help the manual includes drawings of the components with a drawing number to easy find them through the list.

The list includes the reference and description of the spare part.



This page is intentionally left blank.

A. TANK GROUP

N°	Ref.	Description
1	150112110	Complete tank assembly
1.1	150026180	PTFE coated tank
2	150028970	Insulation mantle
3	150112090	Tank port housing
4	150024650	Tank gasket
5	150115280	Tank grid
6	150021790	Plug with o-ring
7	10030007	Current connection strip
8	150114620	Safety thermostat 200°C
9	150022640	Sonde Pt-100
10	150022650	Sonde Ni-120

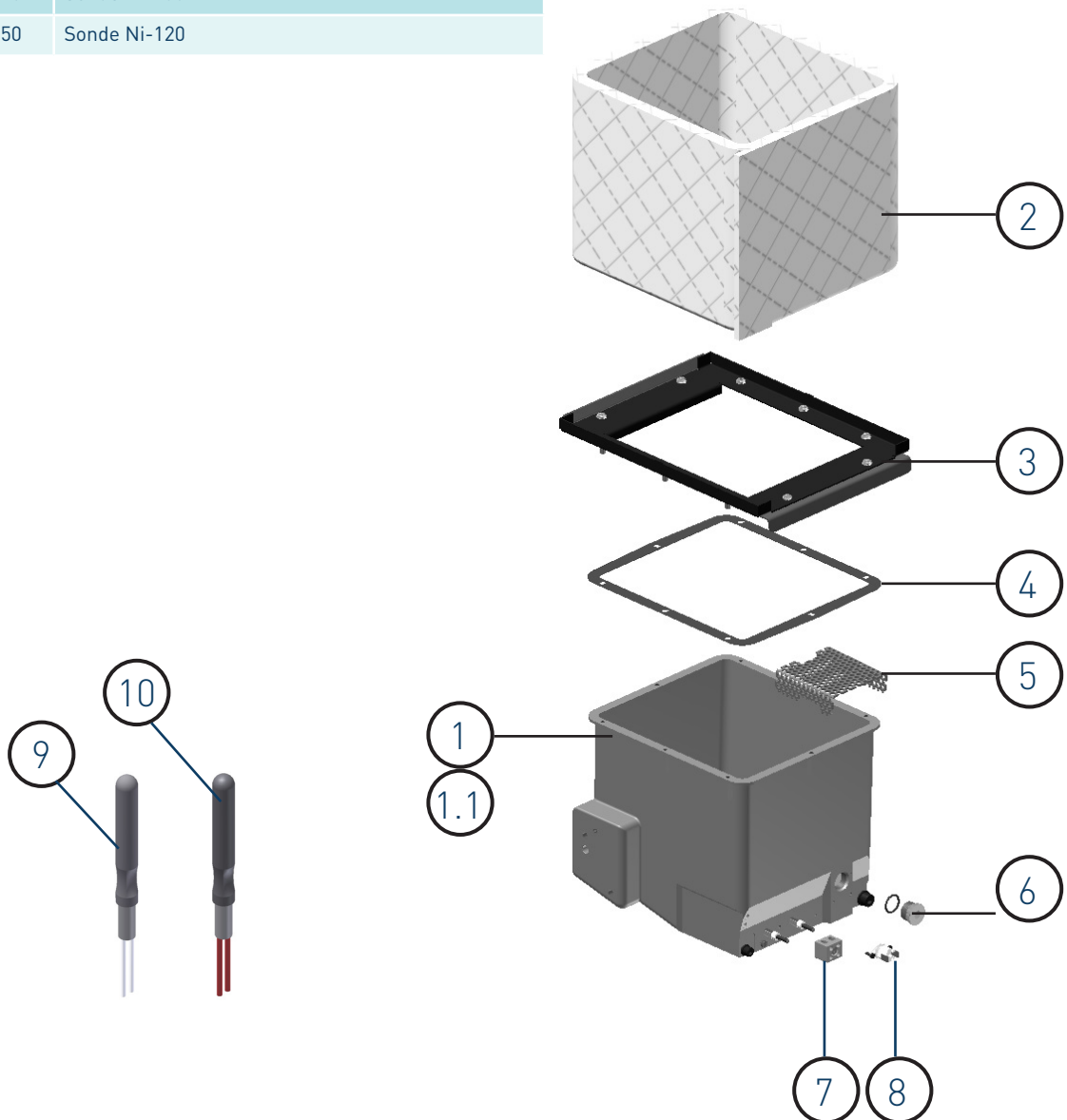

B. DISTRIBUTOR UNIT

N°	Ref.	Descriptionn
1	150113810	Relief valve assembly
1.1	12330087	Relief valve assembly o-ring
1.2	150112820	Relief valve red spring
1.3	150026060	Relief valve closing needle
1.4	150090390	Relief valve seeger ring
2	150090360	Tank-distributor seating o-ring
3	10100082	Pump plug with o-ring
3.1	10100083	Pump plug o-ring
4	10120095	Plug with balancing valve o-ring
4.1	10120096	Balancing valve plug o-ring
5	150029000	Filter plug with o-ring
5.1	10100053	Filter plug o-ring
6	10100090	Pump filter unit
6.1	10100051	Pump filter 100 mesh
7	150026330	Complete purge valve
7.1	150026340	Purge valve o-ring

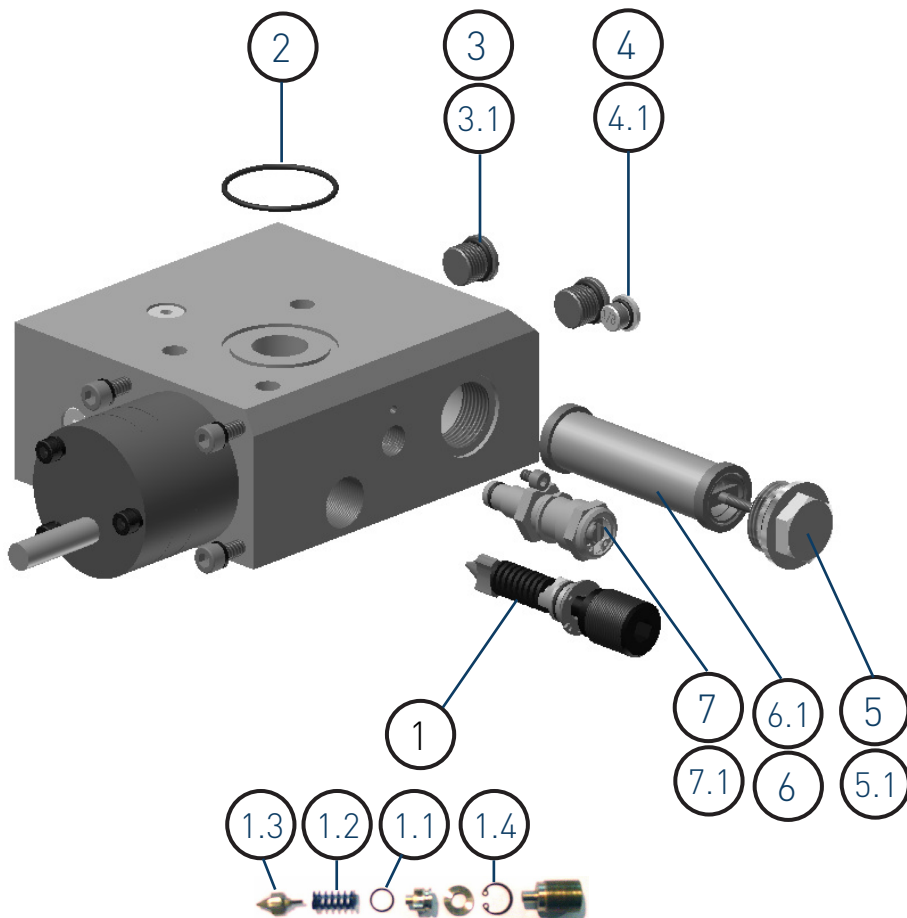

C. MOTOR- PUMP UNIT

N°	Ref.	Description
1	150026110	2cc/rev gear pump
1.1	150090410	Pump seating o-rings
1.2	R0007984	Gasket system in the shaft
2	150026090	Motor coupling
3	150130350	Geared motor 0,12kW+K450
4	150026100	Geared motor support

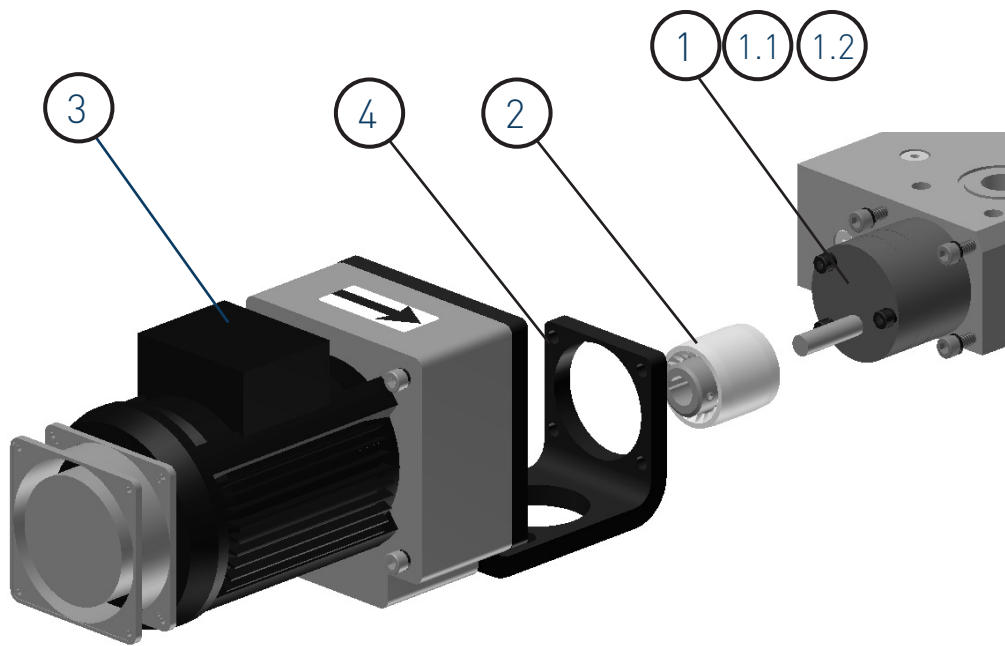

D. ELECTRIC PANEL AND AUXILIARY COMPONENTS

N°	Ref.	Description
1	10000204	Control card
1.1	150112410	Fuse 6,3A 5x20 ultra fast
1.2	150115650	Fuse 10A 6x32 ultra fast
1.3	10010401	Fuse 1A 5x20
2	150117100	Pumping control card
3	16010003	8-pin female connector (base housing)
4	150020720	12-pin female connector (base housing)
5	150021010	Circuit breaker 16A 2-pole
6	10140040	Cable gland Pg 13.5
7	150021590	Cable gland Pg 9
8	150117110	Inverter Siemens G110 0,55kW
9	150117120	Power supply 24V 2,2A
10	150126410	Inverter Siemens V20 0,55kW

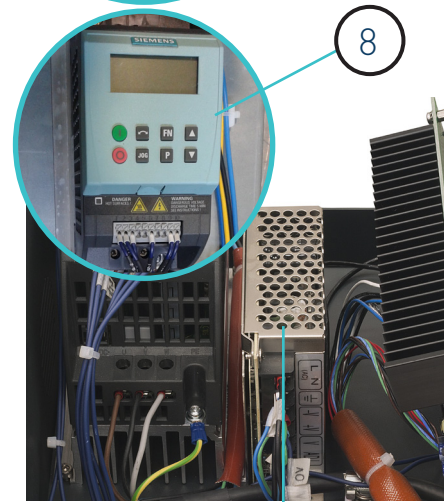
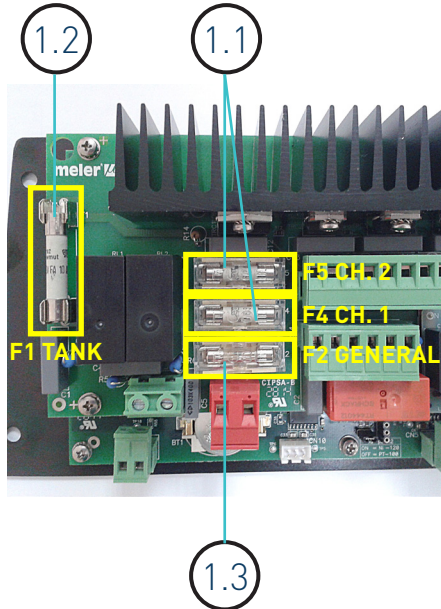

E. WARNING LIGHT UNIT (OPTIONAL)

N°	Ref.	Description
1	150113710	Colourless warning light
1.1	R0006220	Lamp 24V
2	150110140	Capacitive detector
3	150110150	Rechner amplifier
4	150090430	24V AC 2- contact relay

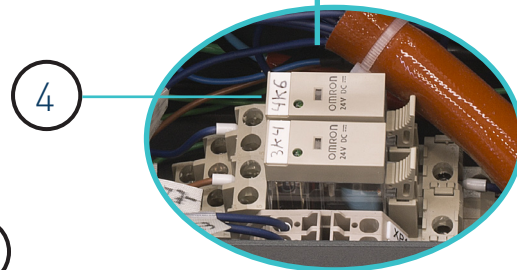

A1. SAFETY GUIDELINES

General

This appendix belongs to 'B4 VARIABLE SPEED' version but its operation and working process are identical to this B4 VS series (see chapter '1. Safety guidelines' in this manual).

The information contained in this section applies not only to everyday machine operation, but also to any procedure carried out on it, whether for preventive maintenance or in the case of repairs and the replacement of worn out parts.

It is very important to observe the safety warnings in this manual at all times. Failure to do so may result in personal injury and/or damage to the machine or the rest of the installation.

Before beginning work on the machine, read this manual carefully, and in case of any doubt, contact our Technical Service Center. We are available for any clarification that you might need.

Keep manuals in perfect condition and within reach of personnel that use the machine and perform maintenance on it.

Also provide necessary safety material: appropriate clothing, footwear, gloves and safety glasses.

In all cases, observe local regulations regarding risk prevention and safety.



This page is intentionally left blank.

A2. INTRODUCTION

This appendix belongs to B4 VS version and it will find information about the installation, use and maintenance of the hot-melt adhesive melter B4 VS WITH AIR-TIGHT LID to get more information see chapter '2. Introduction' in this manual.

This hot-melt equipment is designed to hot-melt adhesive fusion and pumping at temperature up to 200°C. To use higher working temperatures ask for Meler technical department.

Main components

1. Front control card.
2. Pumping control card.
3. Electrical hose-applicator connection.
4. Hydraulic hose-applicator connection.
5. Power switch and input power supply.
6. Pressure relief valve (for non-moisture curing adhesives).
7. Purge valve.
8. Filter pump.
9. Pump system connection switch (optional).
10. Warning light (optional with level detector).
11. Air tight lid.
12. Air drying system (optional).

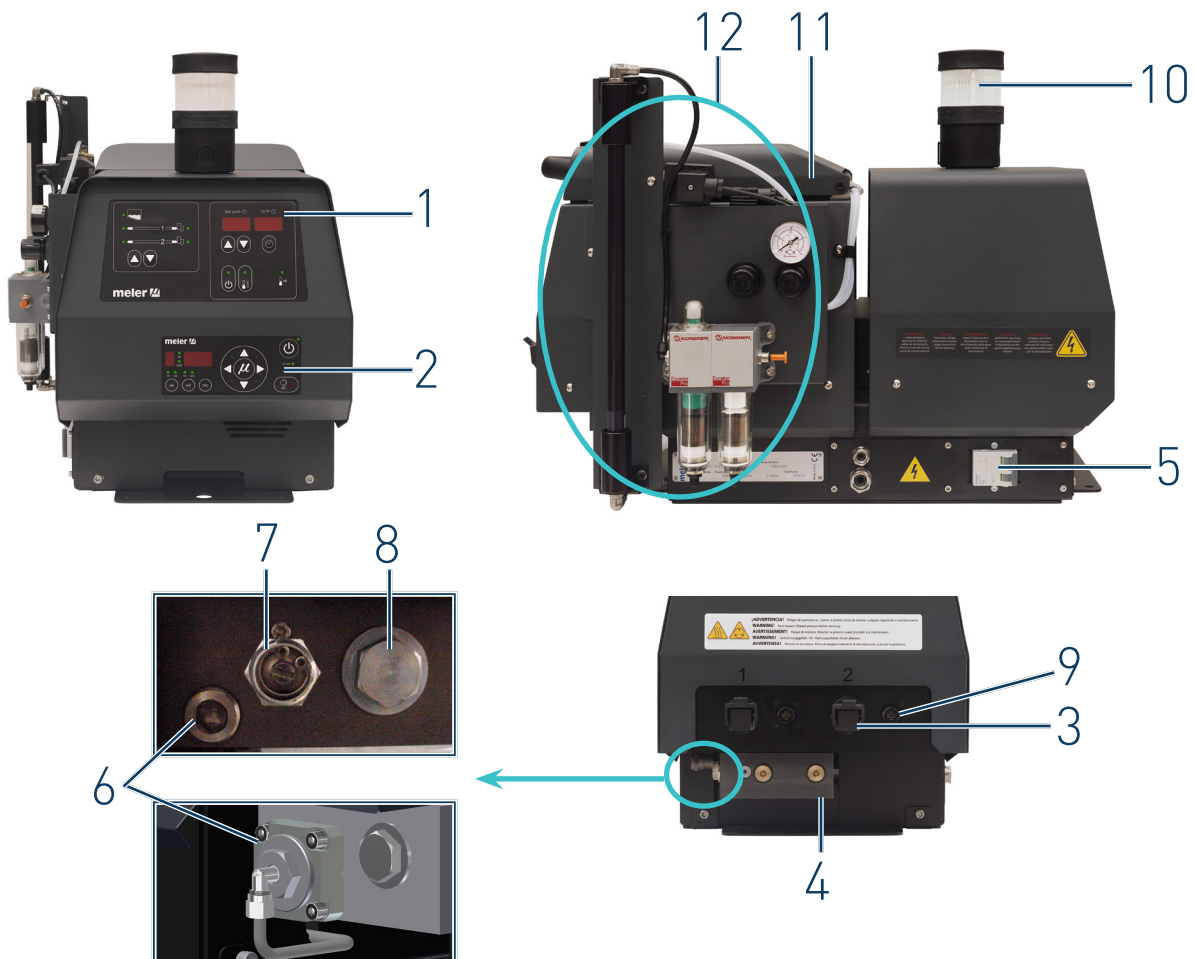

This page is intentionally left blank.

A3. INSTALLATION

Warning: The melters are equipment with current technology and with certain foreseeable risks. Therefore, only allow qualified personnel with sufficient training and experience to use, install or repair this equipment.



Installation requirements

Before installing B4 VS WITH AIR-TIGHT LID series melter equipment, we must make sure that the space assigned to it permits installing, connecting and using the entire system. Similarly, we must check to see that the electrical and pneumatic supplies meet the necessary requirements of the melter equipment being installed see chapter '3. Installation' in this manual.

Free space

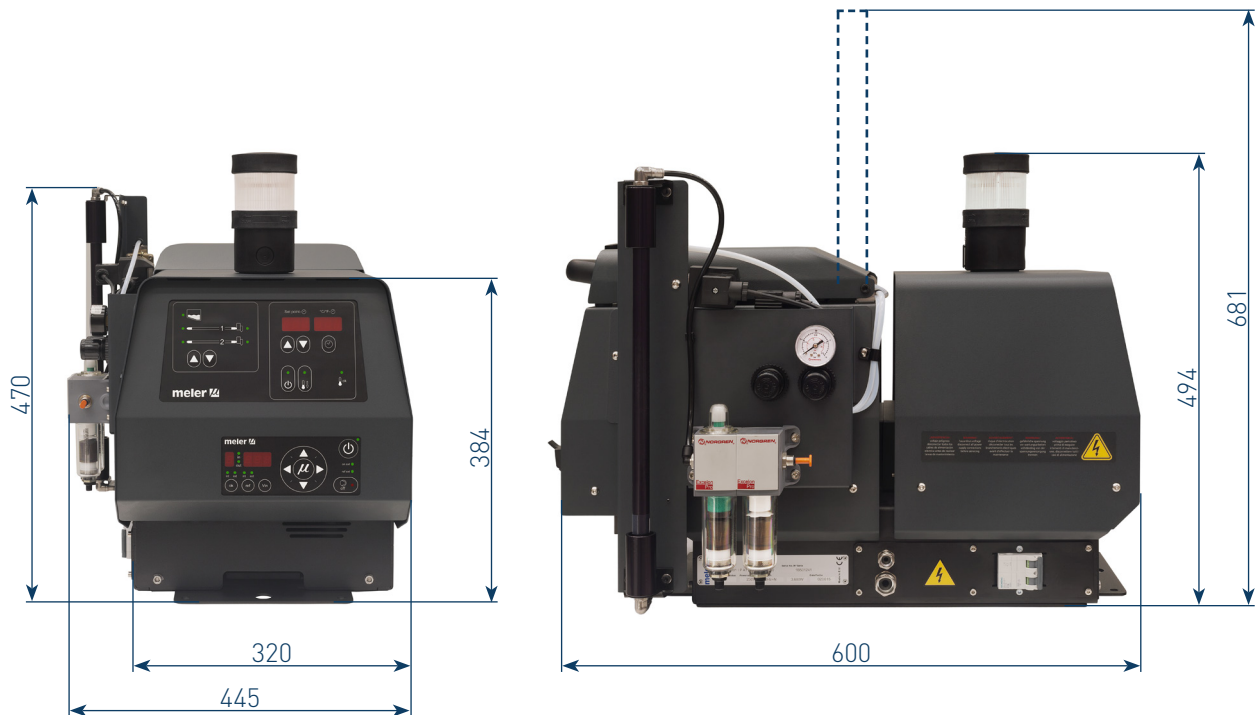

This page is intentionally left blank.

A4. MELTER OPERATION

Airtight lid

An airtight lid is incorporate to close the tank. This option is appropriate when the equipment is going to be used with PUR adhesives. PUR adhesives need a totally dry environment before being applied, since in touch with the dampness of the environment they go hard.

The dry environment is achieved thanks to the incorporation of an air dryer that make possible to extract humidity in a 99.98 % degree. In this way a conservation of the adhesive is guaranteed without hardening premature inside the system of application of the unit.

The dosing system consists in a main pressure regulator, regulated to 0.4 bar, a second pressure regulator, regulated to 0.2 bar, an inlet valve, an exhaust valve that allows to extract the air of the tank, and a programmable relay that drives the valves.

This system uses a programmable relay that enables the programming of two times: a wait time between one air injection and the next (T OFF); and an air injection or air renewal time (T ON). The factory-calibrated values are 5 minutes for (T OFF) and 10 seconds for (T ON). We recommend using a pneumatic pressure of 0.5 kg/cm².

For safety measures the system incorporates an magnetic detector that detects if the top cover is opened or closed. When this top cover gets up or when there is a cut in the electrical supply the exhaust valve opens, consequently pressure inside tank becomes the atmospheric one. The connections of the system can consult in the corresponding chapter 'Electrical drawings'.

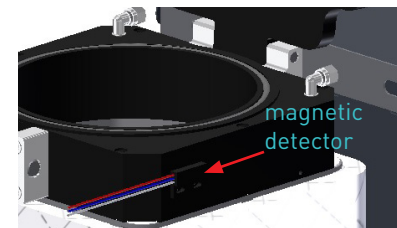
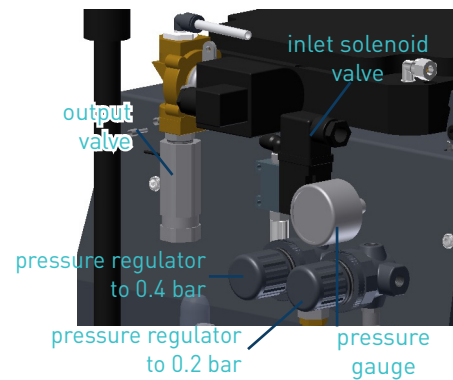

Configuration of air injection times

When you want to change the value of the times programmed into the relay, proceed as follows:

1. Press the ESC key for several seconds until the cursor appears under the first digit of (T.OFF).
2. Use the left-right arrows to move to the value you want to change. Click OK and you will see the digit in negative (light digit over a dark background).
3. Change the value with the up-down arrows.
4. Use the left-right arrow keys to move to a different digit.
5. Once finished, click the OK key to validate the changes and exit editing mode by pushing ESC. The change is now in operation.



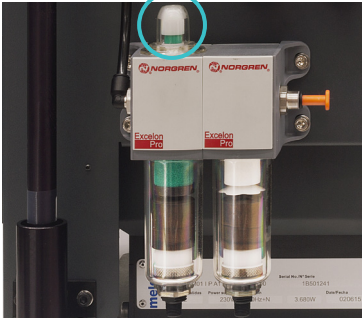

After loading new adhesive or each time that the unit's tank cover is opened, we recommend using the manual injection method for approximately 60 s. To do this, activate the button on the system's electrovalve.

To maintain the air drying system in perfect condition, we recommend periodically observing the green indicator for filter saturation control. If this indicator turns red, it is necessary to replace the filter cartridges. See the corresponding chapter for replacement parts.

Filling the tank

The tank can be equipped with a low level detector that warns when the adhesive is down to one-third of its capacity, approximately.

The unit will activate the external signal and, if it is connected, the corresponding warning device.



Warning: Before refilling the tank, make sure that the adhesive is the same type as that already in the tank. Mixing different types of adhesives can cause damage to the melter equipment.

To fill the tank:

1. Open the top cover and turn the cam handle left up taking it to position that the image shows (1).
2. Take the handle and open the lid until fix the retractable positioner (2).
3. Fill the tank with PUR adhesive block of 2 kg.
4. To close the air-tight, unlock the fixing mechanism, holding the lid with the other hand. Turn the handle in clockwise sense to fix it.
5. Finally close the top cover.

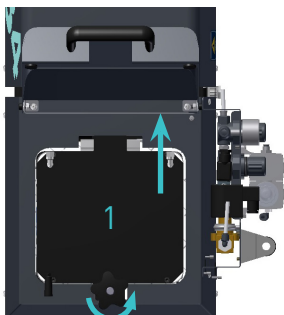

Warning: Risk of burns. Always refill using protective gloves and glasses.

A5. MAINTENANCE

This part of the appendix refers to B4 VS WITH AIR TIGHT LID. To carry out the maintenance in other parts of the equipment, follow the steps in section 'Maintenance' of the B4 VS manual.

Air dryer filter maintenance

The filtering elements prior to the air dryer device on the melting equipment are equipped with a filter saturation indicator, which indicates the best time to change the filter cartridge:

- **Green colour:** Low level of cartridge contamination.
- **Red colour:** The cartridge is contaminated. Replace immediately, otherwise equipment performance cannot be guaranteed.

We recommend installing new cartridges once a year, regardless of the indicator reading (differential pressure).

Follow these steps to change the cartridge:

1. Close the air valve.
2. Release the drainage hose from the reservoir, if connected.
3. Slowly turn the knurled screw clockwise. This will purge the air from the filter.
4. Push the reservoir towards the head of the filter.
5. Slowly turn the reservoir clockwise as far as possible (1/8 of a turn) and remove it, pulling down.
6. Remove the cartridge and replace it with a new one (do not touch the filter screen with your hands).
7. Mount the reservoir, following these instructions in reverse order.
8. Pressurize the filter, opening the by-pass valve slowly.

Warning: It is necessary to keep the power connected to the unit in order to keep the air dryer system operational. The system may operate even with cold adhesive, in order to keep the internal environment moisture-free.

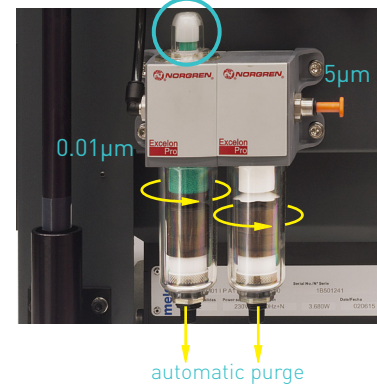
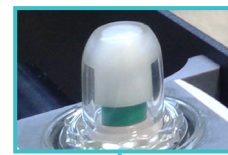

This page is intentionally left blank.

A6. TECHNICAL CHARACTERISTICS

General

Tank volume	4 litres
Maximum pump flow rate (*)	between 1,2 and 15,6 Kg/hr with 2 cc/rev pump
Maximum melting rate (*)	6,0 kg/h
Number of pumps	1
Number of outputs	2
Gear motor	three-phase 179 W two-pole forced ventilation
Pump	2cc/rev
Pump rotation speed	0-100 rpm (recommended 10-80 rpm continuously)
Maximum working pressure	80 bar max. (1160 psi)
	mechanical or pneumatic bypass valve (adjustable)
Total equipment output	3680 W_16 A
External functions	Temperature output ok External standby Starting up the motor Motor speed set point reference Failures output in pump control card
Options	Level control system Air drying system for PUR adhesives
Electrical requirements	LN~ 230 V 50 Hz + PE/ 16A
Room temperature	0 to 40°C
Temperature range	40 to 200°C (100 to 392°F)
Temperature control	RTD $\pm 0.5^{\circ}\text{C}$ ($\pm 1^{\circ}\text{F}$) Pt100 and Ni120
Dimensions	see diagram on following page
Weight	51,5 kg without load (approx)

(*) Under normal conditions

Dimensions

Melting unit

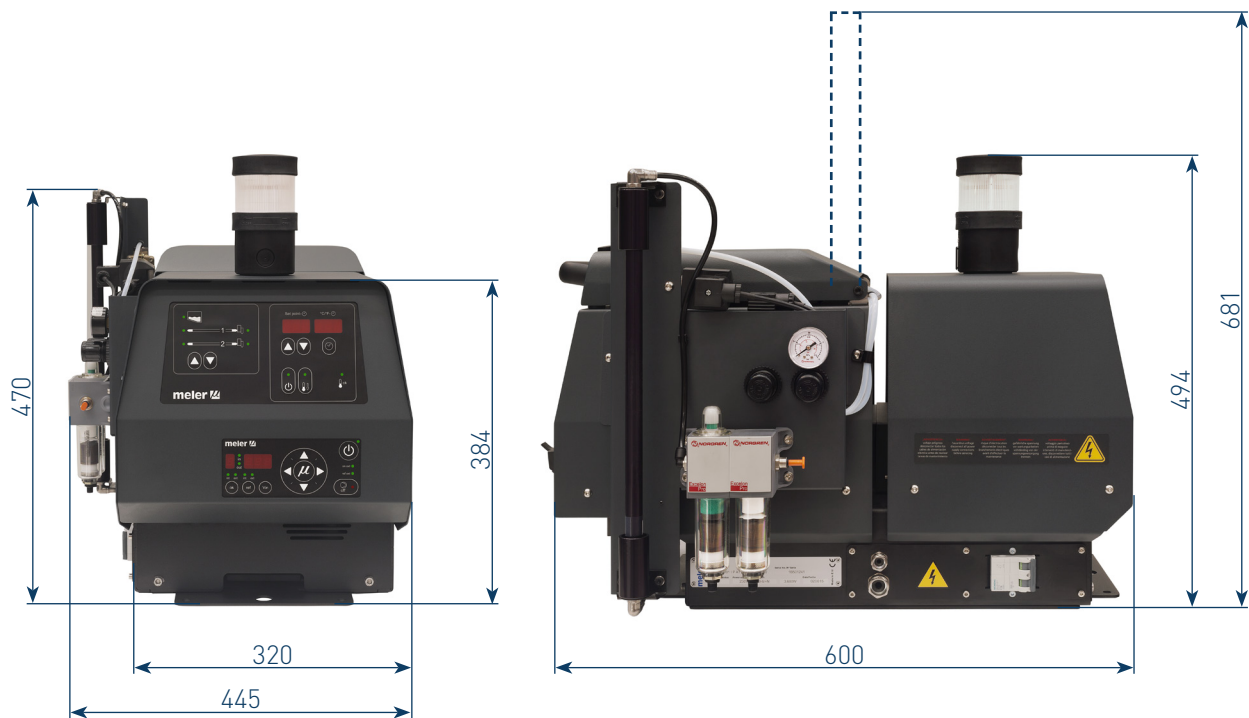

Accessories

Level control system

The level of the hot-melt is done with a capacitive detector and the warning is through a light tower.

Air drying system for PUR adhesives

Polyurethane-based reactive adhesives, known as P.U.R. (reactive polyurethanes), require a completely dry environment before they can be applied, since when they come in contact with atmospheric humidity, they reticulate, hardening quickly.

The B4 VS WITH AIR TIGHT LID melting equipment ensures a dry environment thanks to the addition of an air-drying system to these models, which provides a level of dehumidification above 99.98%. This guarantees that the adhesive is preserved without premature reticulations inside the applicator unit. The installation of the electro-pneumatic control is a standard in all versions. You can choose if you want to order the air-dryer assembly (two filters and the dryer membrane) or not.

A7. ELECTRICAL DRAWINGS

This page is intentionally left blank.

A8. PNEUMATIC DIAGRAM

Component list

Air drying system (optional)

- 1 Filter- 1st stage
Solids/ Oil $5\mu < 1\text{ppm}$
- 2 Filter - 2nd stage
Solids/ Oil $0,01\mu < 0,01\text{ppm}$
- 3 Membrane dryer (Dry air 99,98%)
- 4 3/2 solenoid valve
- 5 Pressure regulator 1-10 bar
- 6 Pneumatic relief valve 0,5 bar
- 7 Pressure regulator 0.1- 0.7 bar
- 8 Pneumatic gauge 0-1.6 bar
- 9 Input pipe
- 10 2/2 output solenoid valve
- 11 Non-return valve 0,5 bar

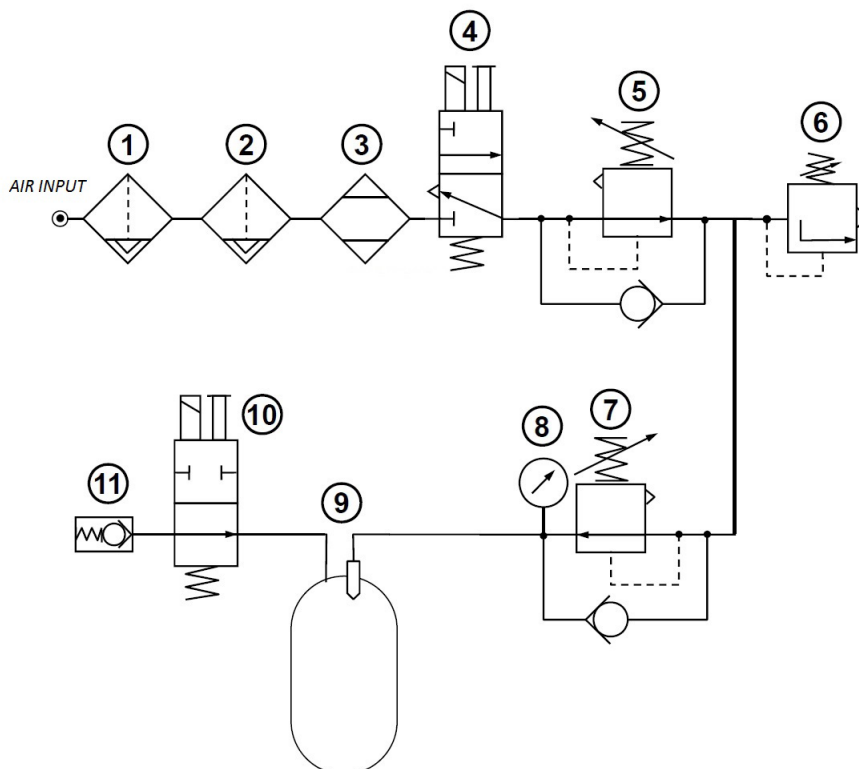

This page is intentionally left blank.

A9. SPARE PART LIST

The most common spare parts list of the B4 VS WITH AIR TIGHT LID adhesive melters is shown in this chapter to give you a quick and sure guideline to choose them.

The spare parts are listed by groups in a natural order as they are located on the units.

As a visual help the manual includes drawings of the components with a drawing number to easy find them through the list.

The list includes the reference and description of the spare part.



A. AIR TIGHT LID

N°	Ref.	Description
1	150113880	PTFE coated tank
2	150028970	Insulation mantle
3	150114550	Tank gasket
4	150113870	Lid gasket
5	150117410	Magnetic detector (cover tank)

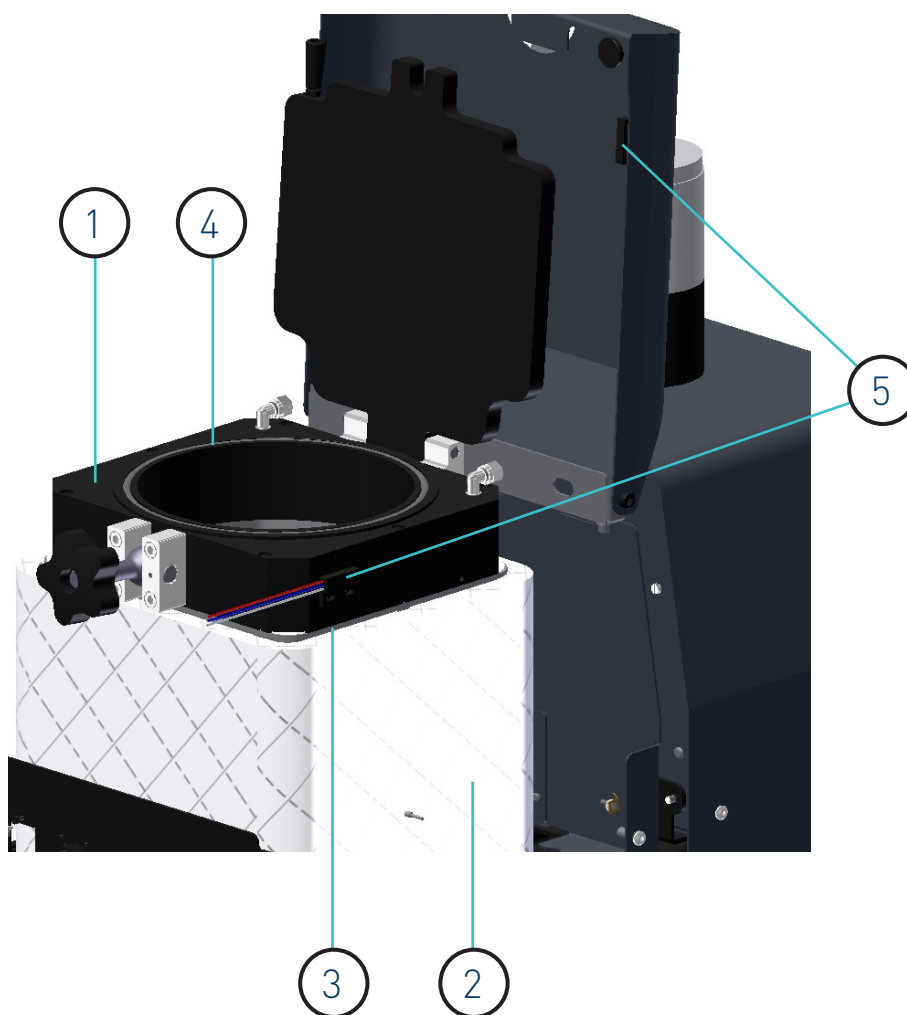

B. AIR DRYER SYSTEM

N°	Ref.	Description
1	150110060	Air dryer cartridge W07M
2	150110400	Air filter Norgren F92G-NNN-AT1 (G1/4)
3	150110390	Air filter Norgren F92C-NND-AT0 (G1/4)
4	10110031	Pressure regulator
5	150029540	Pressure regulator 0,1-0,7 bar
6	150029550	Pressure gauge 0-1,6 bar
7	150028420	Solenoid valve 3/2 1/8 24V DC 5.4W
8	150028400	Solenoid valve 2/2 NA 24V DC 18W
9	150028410	Non-return valve H/H 3/8" 0.5 bar
10	150028380	Pneumatic valve 0.5 bar 1/4"
11	150117130	Programmable relay LOGO

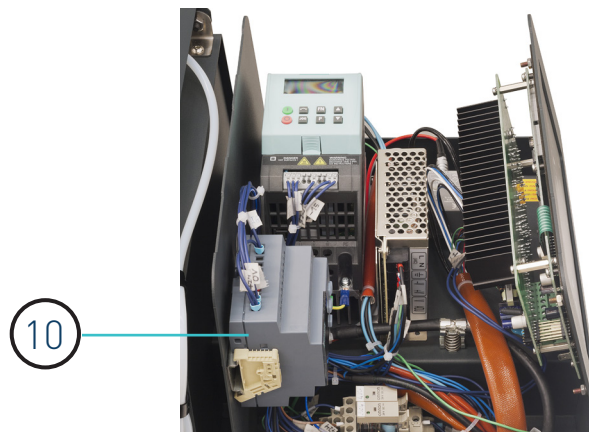
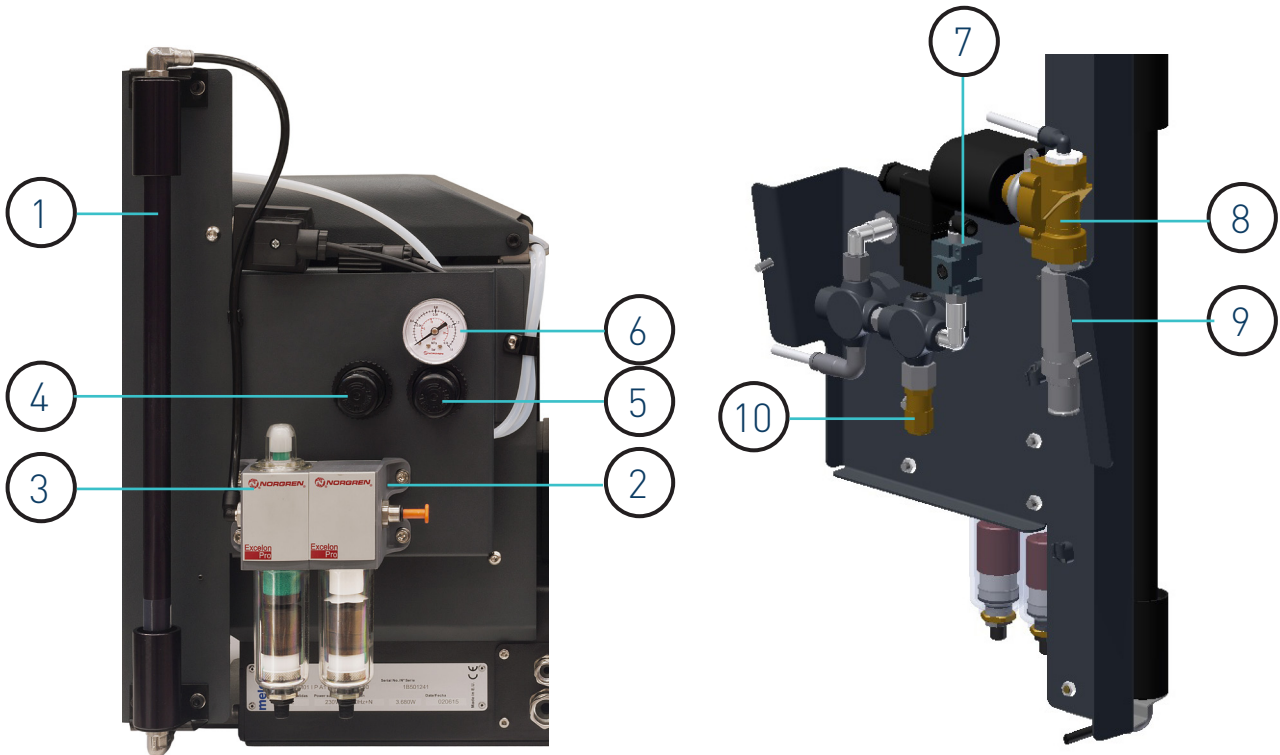

C. WARNING LIGHT UNIT (OPTIONAL)

N°	Ref.	Description
1	150113710	Colourless warning light
1.1	R0006220	Lamp 24V
2	150110140	Capacitive detector
3	150110150	Rechner amplifier
4	150090430	24V AC 2- contact relay

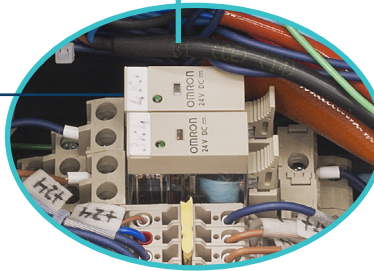

EC DECLARATION OF CONFORMITY

Original Declaration

The manufacturer,

Focke Meler Gluing Solutions, S.A.
Pol. Los Agustinos, c/G, nave D-43
E-31160 Orkoien, Navarra - Spain
— Focke Group —

declaring that the machinery, Type:

Model:

Serial Number:

fulfils all the relevant provisions of the Directive 2006/42/EC on machinery,

and the object of the declaration described above is in conformity with the relevant Union harmonisation legislation:

- Directiva 2014/30/EU on the harmonisation of the laws of the Member States relating to electromagnetic compatibility .
- Directiva 2011/65/EU and its amendments on the restriction of the use of certain hazardous substances in electrical and electronic equipment.

In reference to the harmonised standards:

- EN ISO 12100:2010. Safety of machinery - General principles for design - Risk assessment and risk reduction.
- EN ISO 13732-1:2008. Ergonomics of the thermal environment - Methods for the assessment of human responses to contact with surfaces - Part 1: Hot surfaces.
- EN ISO 13849-1:2015. Safety of machinery - Safety-related parts of control systems - Part 1: General principles for design.
- EN ISO 14120:2015. Safety of machinery - Guards - General requirements for the design and construction of fixed and movable guards.
- EN 60204-1:2018. Safety of machinery - Electrical equipment of machines - Part 1: General requirements.
- EN 61000-6-2:2005, +/AC:2005. Electromagnetic compatibility (EMC) - Part 6-2: Generic standards - Immunity for industrial environments.
- EN 61000-6-4:2007, +/A1:2011. Electromagnetic compatibility (EMC) - Part 6-4: Generic standards - Emission standard for industrial environments.
- EN 50581:2012. Technical documentation for the assessment of electrical and electronic products with respect to the restriction of hazardous substances.

This declaration of conformity is issued under the sole responsibility of the manufacturer.

The person authorised to compile the technical file is the manufacturer established at the above address in this declaration.

Signed in Orkoien, to date:



Javier Aranguren
Managing Director

For more information speak with your Focke Meler representative:



Focke Meler Gluing Solutions, S.A.
Pol. Arazuri-Orkoién, c/B, nº3 A
E-31170 Arazuri - Navarra - Spain
Phone: +34 948 351 110
info@meler.eu - www.meler.eu

Focke Group