

Instructions manual

ADHESIVE MELTER MICRON SERIES

Geat



meler 

MA-5050-E 280512



Published by:

meler Aplicadores de Hot-melt S.A.
P.I. Los Agustinos, calle G, nave D-43
E - 31160 ORCOYEN Navarra (Spain)

Phone.: + 34 948 351 110

Fax: + 34 948 351 130

e-mail: info@meler.es

web site: www.meler.eu

Edition May 2012

© Copyright by meler

All rights reserved. Its reproduction, diffusion or use by electronic or other means of all or any part of this document without the express authorization of its owner is strictly prohibited.

The specifications and information contained in this manual may be modified without prior notice.

TABLE OF CONTENTS

1. SAFETY GUIDELINES	1-1
<i>General</i>	1-1
<i>Symbols</i>	1-1
<i>Mechanical components</i>	1-2
<i>Electrical components</i>	1-2
<i>Hydraulic components</i>	1-2
<i>Thermal components</i>	1-3
<i>Noise</i>	1-3
<i>Materials</i>	1-3
2. INTRODUCTION	2-1
<i>Description</i>	2-2
Intended use	2-2
Limited use	2-3
Modes of operation	2-3
Hot-melt melter/applicator identification	2-4
<i>Main components</i>	2-4
<i>Optional Equipment</i>	2-7
3. INSTALLATION	3-1
<i>Introduction</i>	3-1
<i>Installation requirements</i>	3-1
Free space	3-1
Electrical consumption	3-2
Compressed air	3-2
Other factors	3-3
<i>Unpacking</i>	3-3
Contents	3-3
<i>Mounting the equipment</i>	3-4
<i>Electrical power connection</i>	3-4
<i>Pneumatic connection</i>	3-5
<i>Hose and gun connection</i>	3-6
<i>Parameter Programming</i>	3-6
Programming working temperatures	3-7
Selecting the overheating value	3-7
Keeping a component on display	3-8

External I/O connections	3-8
Temperature ok	3-9
External standby	3-10
Low level (optional)	3-10
Output inhibitor	3-11
Starting up the motor	3-12
Motor speed set point reference	3-12
4. MELTER OPERATION	4-1
General information	4-1
Filling the tank	4-2
Starting up the melter/applicator equipment	4-2
Melter/applicator equipment displays	4-3
Displaying the temperature for each component	4-4
Alarm displays	4-5
Hot-melt display level (optional)	4-6
Operating speed display and adjustment	4-7
Temperature adjustment	4-7
Programming the applicator parameters	4-8
Setting the clock	4-9
Programming the current day and hour	4-9
Programming equipment activation/deactivation	4-10
Disabling the equipment activation/deactivation program	4-11
Programming the equipment's standby function activation/deactivation	4-11
Disabling the equipment standby function programming	4-12
Special function buttons	4-13
Pump speed control	4-14
Manual mode	4-14
Automatic mode with an internal set point signal	4-15
Automatic mode with an external set point signal	4-15
By-pass valve regulation	4-16
Manual valve control	4-17
Pneumatic valve control	4-17
Turning off the melting equipment	4-17
Using the air drying system	4-18
5. MAINTENANCE	5-1
Equipment cleaning	5-1
System depressurization	5-2
Filter maintenance	5-2

<i>Cleaning the tank</i>	5-4
Changing adhesive type.	5-4
Cleaning burnt adhesive.	5-4
Emptying the tank	5-5
<i>Pump maintenance</i>	5-6
Inspecting for leaks	5-6
<i>Motor-gear maintenance</i>	5-6
Cleaning the motor fan	5-6
Checking the lubricant	5-6
<i>Air drier filter maintenance</i>	5-7
6. TECHNICAL CHARACTERISTICS	6-1
<i>General</i>	6-1
<i>Dimensions</i>	6-2
<i>Accessories</i>	6-3
7. ELECTRICAL DRAWINGS	7-1
<i>Components list version Pt-100</i>	7-1
Version with a single pump installed	7-1
Version with two pumps installed	7-2
<i>Components list version Ni-120</i>	7-3
Version with a single pump installed	7-3
Version with two pumps installed	7-4
8. PNEUMATIC DIAGRAM	8-1
<i>Components list</i>	8-1
Pneumatic by-pass valve control system	8-1
Air drying system	8-1
9. SPARE PARTS LIST	9-1
<i>A. TANK GROUP</i>	9-4
<i>B. DISTRIBUTOR GROUP</i>	9-5
<i>C. TANK-DISTRIBUTOR ASSEMBLY GROUP</i>	9-6
<i>D. MOTOR-PUMP GROUP</i>	9-7
<i>E. CHASSIS GROUP</i>	9-8
<i>F. ELECTRICAL CABINET</i>	9-9
<i>G. AUXILIARY ELECTRICAL COMPONENTS</i>	9-10
<i>H. AIR DRYER GROUP (OPTIONAL)</i>	9-11

This page is intentionally left blank.

1. SAFETY GUIDELINES

General

The information contained in this section applies not only to every-day machine operation, but also to any procedure carried out on it, whether for preventive maintenance or in the case of repairs and the replacement of worn out parts.

It is very important to observe the safety warnings in this manual at all times. Failure to do so may result in personal injury and/or damage to the machine or the rest of the installation.

Before beginning work on the machine, read this manual carefully, and in case of any doubt, contact our Technical Service Center. We are available for any clarification that you might need.

Keep manuals in perfect condition and within reach of personnel that use the machine and perform maintenance on it.

Also provide necessary safety material: appropriate clothing, footwear, gloves and safety glasses.

In all cases, observe local regulations regarding risk prevention and safety.

Symbols

The symbols used on both the melter/appliator equipment and in this manual always represent the type of risk we are exposed to. Failure to abide by a warning signal may result in personal injury and/or damage to the machine or the rest of the installation.



WARNING: Risk of electrical shock. Carelessness may produce injury or death.



WARNING: Hot zone with high temperatures. Risk of burns. Use thermal protective equipment.



WARNING: System under pressure. Risk of burns or particle projection. Use thermal protective equipment and glasses.

WARNING: Important information for the correct use of the system. May include one or several of the previous hazards, and therefore must be kept in mind to avoid damage and injury.



Mechanical components

The melter/applicator equipment installation uses moveable parts that may cause damage or injury. Use the equipment correctly, and do not remove the safety guards while the equipment is in operation; prevent the risk of possible entrapment due to moving mechanical parts.

Do not use the machine if the safety devices are not in place or appear to be inadequately installed.

For maintenance or repair operations, stop the movement of moveable parts by turning off the main switch.

Electrical components

The system operates with a one-phase current (230 V / 50 Hz) or a three-phase current (3x400 V + N / 50 Hz) at a certain rated power. Never handle the equipment with the power connected, as this may result in powerful electrical shocks.

The installation must be correctly grounded.

The installation's power cable conductors must match the required electric current and voltage.

Periodically inspect the cables to check for crushing, wear and tear, as well as to prevent tripping and falls as a result of their placement.

Although the system meets *EMC* requirements, it is inadvisable to use devices that transmit high levels of radiation, i.e., mobile phones or soldering equipment in their vicinity.

Hydraulic components

As this is a pressurized system, precautions related to this type of equipment must be observed.

Before each operation, always make sure that the adhesive circuit is completely free of pressure. There is a high risk of hot particle projection, along with the corresponding danger of burns.

Use caution with the residual pressure that may remain in the hoses when the adhesive cools. When reheated, there is a risk of hot particle projection if the outputs are left open.

Thermal components

The entire system operates with temperatures reaching up to 230 °C (446 °F). The equipment must be operated using adequate protection (clothing, footwear, gloves and protective glasses) that completely cover exposed parts of the body.

Keep in mind that, due to the high temperatures reached, the heat does not dissipate immediately, even when the power (in this case, electric) source is disconnected. Therefore, use caution, even with the adhesive itself. It may remain very hot, even in a solid state.

In case of burns, immediately cool the affected area with clean, cold water. Seek medical attention as soon as possible from the company's medical service or the nearest hospital. Do not try to remove the adhesive material from the skin.

Noise

The noise level of the system is well below allowable levels, and therefore does not present a specific risk to be taken into consideration.

Materials

'meler' systems are designed for use with hot-melt adhesives. They should not be used with any other type of material, and especially not with solvents, which may cause personal injury or damage to internal system components.

Always use original 'meler' components and replacement parts, which guarantee the correct system operation and service.

When using adhesive, follow the corresponding guidelines found in the *Technical and Safety Sheets* provided by the manufacturer. Pay special attention to the advised work temperatures in order to prevent adhesive burning and degradation.

Ventilate the work area adequately in order to remove the vapors produced. Avoid the prolonged inhalation of these vapors.



This page is intentionally left blank.

2. INTRODUCTION

In this manual you will find information about the installation, use and maintenance of the hot-melt adhesive melter/appliator in *meler's micron gear* series.

The '*micron gear*' series includes the 4, 8, 16 and 32 liter range of hot-melt adhesive melters/appliators.

Most of the photographs and illustrations that appear in this manual refer to the 8-liter '*micron gear*' melter/appliator. This model has been used as a reference for writing this manual as its main characteristics, with the exception of the tank capacity and the connection outputs are the same as those in the rest of the '*micron gear*' series.





Description

The '*micron gear*' are designed for use with '*meler*' hoses and guns in hot-melt adhesive applications. Their different variations – line, coating or swirl-spray – cover a wide range of applications, being very versatile in all markets where they are used.

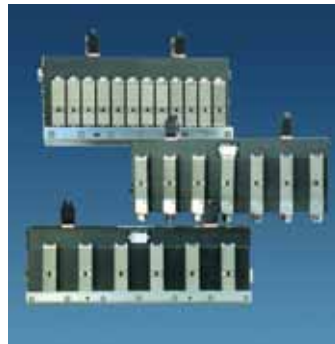

Intended use

The hot-melt melters/applicators in the '*micron gear*' series are designed to be used in the following conditions:

- Hot-melt adhesive fusion and pumping at temperatures up to 200°C (230°C in option)
- Use of hot-melt melters/applicators with '*meler*' accessories
- Installation of hot-melt melters/applicators according to the security regulations currently in force and the instructions provided in this manual (anchoring, electrical connection, hydraulic connection, etc)
- Use of hot-melt melters/applicators in non-explosive, non-chemically aggressive environments
- Use of hot-melt melters/applicators following the safety instructions indicated in this manual, as well as on the labels accompanying the equipment, using adequate means of protection during each mode of operation.

Limited use

The '*micron gear*' series hot-melt melters/applicators must be used for their intended uses and never in the following conditions:

- Use with adhesives or any other material that might cause safety or health risks when heated.
- Use of hot-melt melters/applicators in environments where cleaning is necessary using water jets.
- Use of hot-melt melters/applicators to heat or melt food products.
- Use or operation without adequate safety protection.

Modes of operation

The '*micron gear*' series hot-melt melters/applicators may be used in all of the following modes:

Work mode_The melting equipment keeps the hot elements at the temperature indicated on the display, which has been preselected to the desired value. The pump-motor set remains active, on standby to receive the consumption request by the opening of one or more applicator guns.

manual control_The pump motor is started by means of the switch in 'MANUAL' position. The rotational speed of the motor is selected by turning the 'R.P.M.' control.

automatic internal set point control_ Switches are in 'AUTO' and 'REF INT' position. The pump motor is started by means of an external signal contact. The rotational speed of the motor is selected by turning the 'R.P.M.' control.

automatic external set point control_ Switches are in 'AUTO' and 'REF EXT' position. The pump motor is started by means of an external signal contact. The rotational speed of the motor is selected by means of a 0-10V external control signal.

Standby mode_The melting equipment remains on standby status, with the temperatures of the elements at a value (which may be programmed) that is below the preselected value. The pump-motor remains deactivated.

Alarm mode_The melting equipment detects a malfunction and warns the operator about the event. The pump-motor remains deactivated.

Stop mode_The melting equipment remains off, no elements are heated and the pump-motor assembly is deactivated. However, the electrical and pneumatic power from the grid, if any, are still supplied to the equipment.



Hot-melt melter/appliator identification

When placing orders for replacement parts or requesting help from our service center, you should know the model and reference number of your hot-melt melter/appliator.

This and other technical information will be found on the identification plate located on the side of the lower part of the hot-melt melter/appliator.

Main components



1. Front control card
2. Access door to the electronic section and connections.
3. Tank access cover
4. Air pressure gauge
5. By-pass valve pressure regulator (optional system)
6. Motor control panel
7. Unit transport wheels (optional)
8. Hose output distributor (up to 2 hydraulic connections per motor-pump assembly)
9. Hose-gun electrical connections
10. Main switch and electrical connection
11. Optional air drying system for PUR adhesives

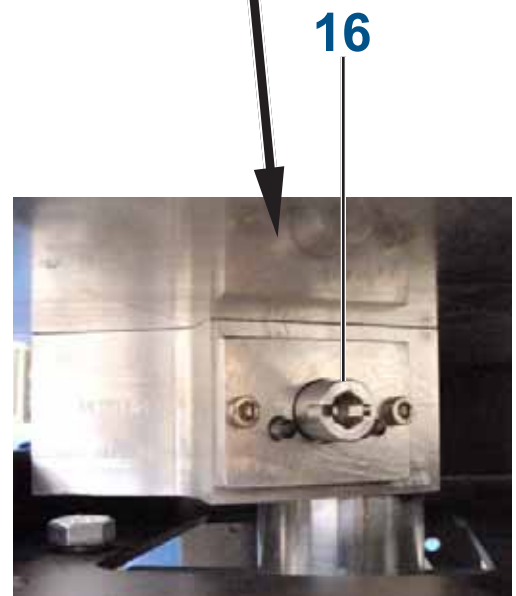
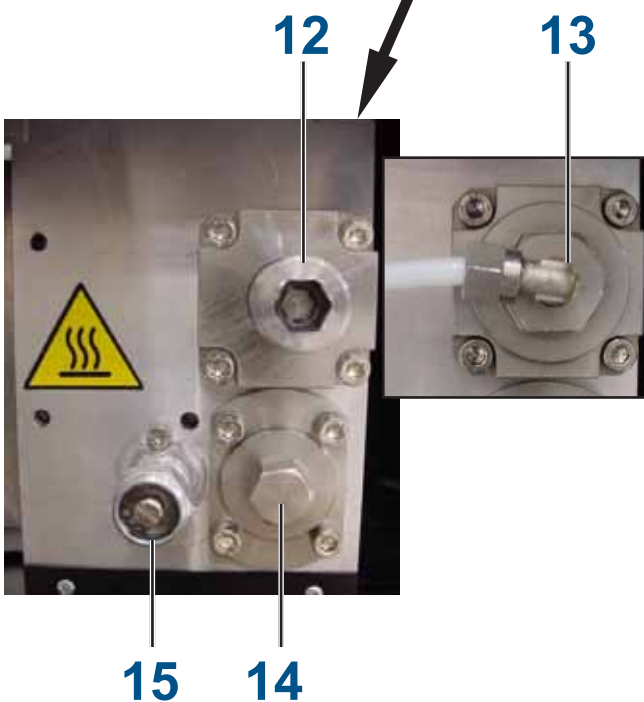

12. Mechanical by-pass valve pressure control
13. Pneumatic by-pass valve pressure control (optional system)
14. Pump filter
15. Purge valve
16. Tank-distributor shut off valve

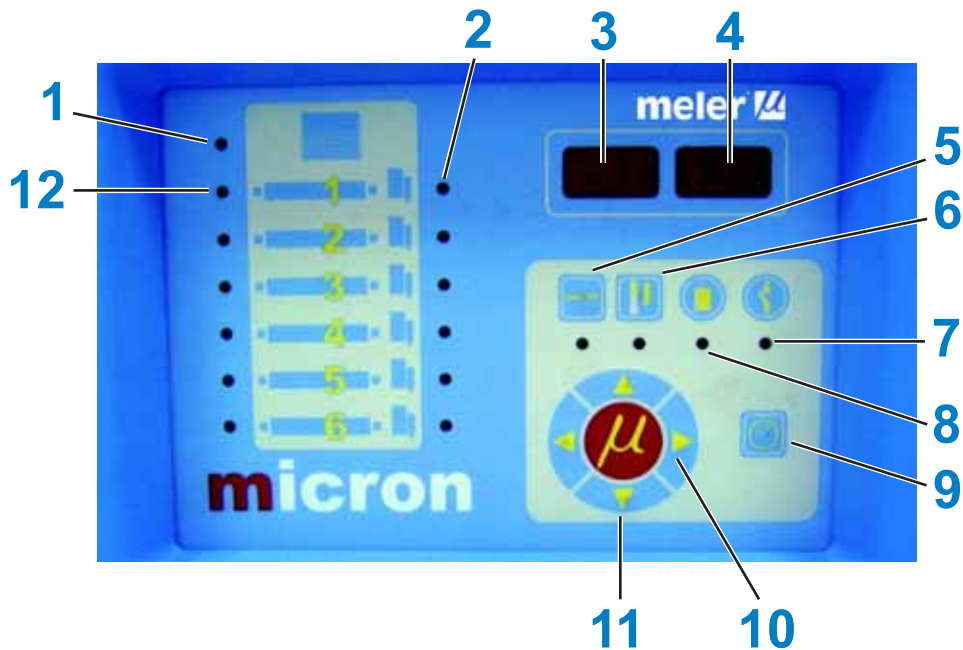

- 1. Tank indicator LED
- 2. Gun indicator LED
- 3. Temperature set point
- 4. Actual Temperature
- 5. ON/OFF switch
- 6. Standby function
- 7. Temperature OK LED
- 8. Pump operation LED
- 9. Time scheduling
- 10. Left/right button - channel selection
- 11. Up/down button - temperature modification
- 12. Hose indicator LED



For each motor-pump assembly installed:

- 13. Pump speed display
- 14. 'MANUAL / 0 / AUTO' mode switch
- 15. INTERNAL / EXTERNAL set point switch
- 16. Maximum 'RATIO' speed control
- 17. Motor 'R.P.M.' speed regulation

Main components 'micron gear' two motor-pumps

Marking of the micron gear components are the same for all models. In this chapter the photographs refer to the 32-liter 'micron gear' melter/applcator.



For each motor-pump assembly installed:

1. Pressure regulator 1
2. Pressure regulator 2
3. Hoses outlet 1
4. Hoses outlet 2
5. Gear motor 1
6. Gear motor 2



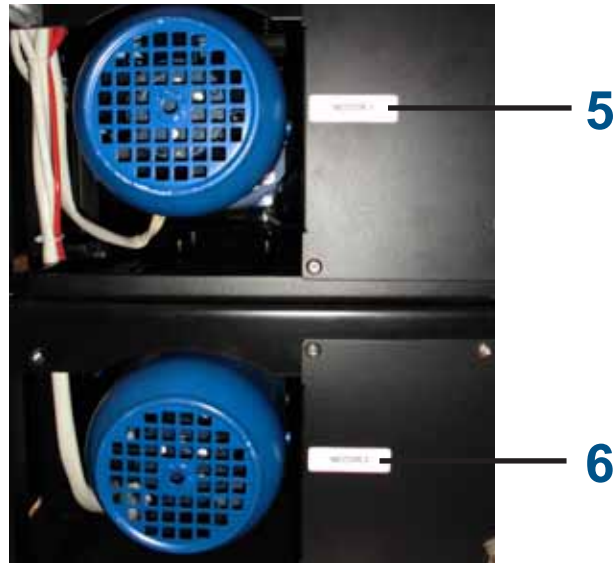

Optional Equipment

In order to provide the melting equipment with more functions, the following optional elements may be added:

- Pneumatic by-pass valve pressure control system. The pressure on the valve has a 15 to 1 ratio to the pressure shown on the pressure gauge.
- Air drying system for use with PUR adhesives.
- Low melted adhesive level detection system.
- Automatic tank filling system.

3. INSTALLATION



Warning: The melters/applicators are equipment with current technology and with certain foreseeable risks. Therefore, only allow qualified personnel with sufficient training and experience to use, install or repair this equipment.

Introduction

The 'micron gear' series melters/applicators are delivered with all the materials necessary for their installation. However, some components must be provided by the user himself, according to the location and connections in each particular installation:

- Anchoring screws for the melter/applicator equipment
- Power cord and plug for electrical power
- Pneumatic conduct and connection to the compressed air system
- Multicore cable for external electrical control
- Optionally, a gas ventilation system

Installation requirements

Before installing 'micron gear' series melter/applicator equipment, we must make sure that the space assigned to it permits installing, connecting and using the entire system. Similarly, we must check to see that the electrical and pneumatic supplies meet the necessary requirements of the melter/applicator equipment being installed.

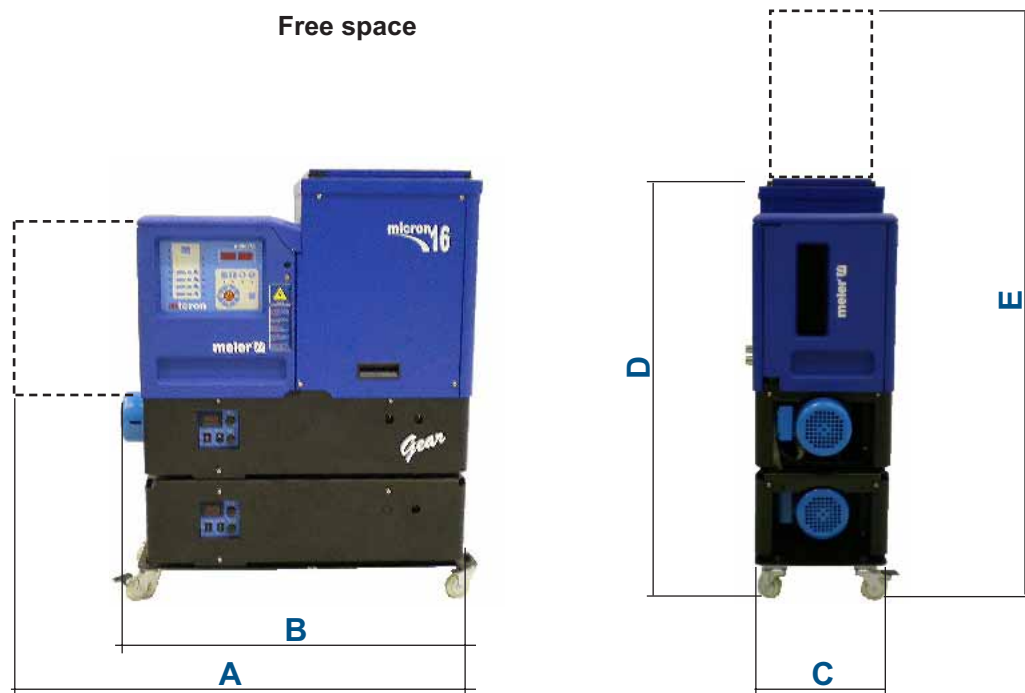

item	description	dimension			
		single pump		two pumps	
A	EQUIPMENT LENGTH WITH DOOR OPEN	4L	810 mm		
		8L	886 mm		
		16L	968 mm		
B	EQUIPMENT LENGTH	4L	650 mm		
		8L	726 mm		
		16L	809 mm		
C	EQUIPMENT WIDTH	4L	308 mm		
		8L	308 mm		
		16L	308 mm		
D	EQUIPMENT HEIGHT	4L	660 mm	4L	860 mm
		8L	660 mm	8L	860 mm
		16L	760 mm	16L	960 mm
E	EQUIPMENT HEIGHT WITH LID OPEN	4L	794 mm	4L	994 mm
		8L	830 mm	8L	1030 mm
		16L	1089 mm	16L	1289 mm

Electrical Consumption

In order to install a '*micron gear*' series melter/applicator, we should take into consideration the total consumption of the installation, including the consumption of the installed hoses and guns.

Before connecting, make sure that the voltage that is being connected to the melter/applicator is the correct one appearing on the equipment's characteristics plate.

Connect the machine and check to see if it is well grounded.

Warning: Risk of electrocution. Even when the equipment is turned off, voltage remains in the intake terminals, which may be dangerous during internal equipment manipulations.



Install a power switch for disconnecting the melter/applicator equipment from the electrical network.

Compressed air

As an option, a pneumatically activated by-pass valve or an air drying system may be installed. If these are added to the system, a dry, unlubricated compressed air network must be available, with a maximum pressure of 6 bar.

The by-pass valve consumes next to no air, given that this is a pressurized closed circuit. In the case of the air drier, this depends on the frequency of application, and therefore consumption must be estimated for each case. Generally speaking, we can give a maximum consumption value of 4.5 l/min for a pressure of 0.5 bar

with a standard cycle setting (10 min standby / 10 s application).

Other factors

While installing '*micron gear*' series melters/applicators, other practical considerations should be kept in mind:

- Keep the load opening accessible for comfortable melter/ applicator filling
- Position the melter/applicator equipment in such a way that you can easily see the front panel display where temperatures and possible alarm signals are shown
- As much as possible, try to avoid unnecessarily long hoses that result in elevated electrical energy consumption levels and pressure drops
- Do not install the melter/applicator equipment beside powerful heat or cooling sources that may have distortional effects upon its operation
- Avoid melter/applicator vibrations
- Make sure that the melter/applicator maintenance areas (filter, purging valve, tank interior, etc.) are easily accessible

Unpacking

Before proceeding with the installation of the melter/applicator, it should be removed from its location on a pallet and examined in order to detect any possible breakage or deterioration. Communicate any defect, even to the outer packing materials, to your '*meler*' Representative or to the Main Office.

Contents

The '*micron gear*' series packing materials may contain accessories that form part of the same order. If this is not the case, the following are the standard components that accompany the melter/applicator:

- Instruction manual
- Guarantee card
- Hose couplings
- Electrical wall bushing Pg
- Connector for external I/O (included on the power card)

Mounting the equipment

The 'micron gear' series melting equipment are equipped (optional) with wheels for their easy transport and positioning near the main machine.

The four wheels turn 360°, and two are equipped with brakes. To move the unit, unlock the two wheels by lifting the lever.

Slide the unit to its final position. Lock the wheels once again, lowering the levers.

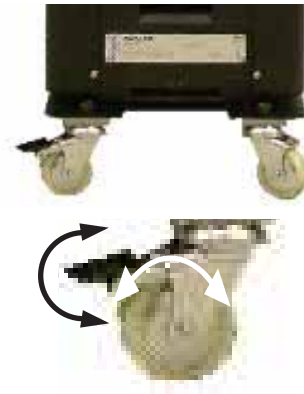

Electrical power connection

'micron gear' series melters/applicators are designed to be connected to the electrical power supply in three possible ways, depending on their power consumption:

- 1-phase 230 VAC
- 3-phase 400 VAC with neutral

A good ground connection is required in all cases.

Consumption figures, according to melter/applicator and output configuration, are included in the table.

UNIT	No. OUTPUTS	1 PHASE		3 PHASES	
		1 PUMP	2 PUMPS	1 PUMP	2 PUMPS
micron 4	2	26.3 A	31.3 A	14.0 A	12.2 A
	4	36.8 A	41.8 A	14.0 A	17.4 A
	6	47.2 A	-	17.6 A	-
micron 8	2	30.7 A	35.6 A	18.3 A	13.1 A
	4	41.1 A	46.1 A	18.3 A	17.4 A
	6	51,6 A	-	18.3 A	-
micron 16	2	32.9 A	37.9 A	20.5 A	15.3 A
	4	43.3 A	48.3 A	20.5 A	17.4 A
	6	53,7 A	-	20.5 A	-

Warning: Risk of electrical shock. Carelessness may cause injury or death.

Install the electrical wall bushing Pg 13.5 in the area reserved for them, fastening them to the plate with the appropriate nut.



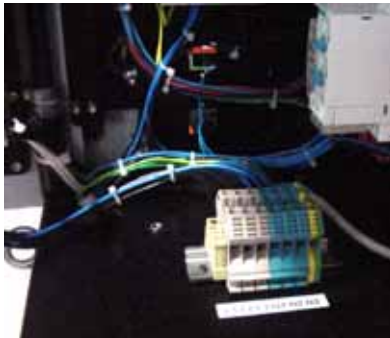

Open the electric cabinet door as far as possible. Thread the power cord (Ø6-12 mm) through the electrical wall bushing Pg 13.5 and fasten it to the inside anchor, making sure that the cord reaches the power terminal block at the position where it will be installed.

Connect each wire in the power cord to its corresponding place on the power terminal block in the unit



L1 L2 L3 N1 N2 N3



1 x 230V + N



3 x 400V + N

Pneumatic connection



If a pneumatically controlled by-pass pressure control valve is installed, the equipment must have a compressed air supply.

Before connecting the pneumatic power to the melter/applicator, make sure the pressure regulator is completely closed. To do this, turn the regulator handle located on the equipment base next to the pressure gauge counterclockwise as far as it will go.



Connect the plant air supply (max. 6 bar) to the melter/applicator intake using flexible tubing with an outside diameter of 6 mm. The equipment is provided with a quick coupling for this purpose.

Activate the air supply to pass and turn the pressure regulator clockwise. The ratio between the pneumatic pressure and the hydraulic pressure on the circuit is 1 to 15 bar.



Warning: A 6 bar on the grid, the maximum pressure on the hydraulic circuit reaches 90 bar. There is a risk of burns or particle projection. Use thermal protective gear and goggles.

Hose and gun connection

'micron gear' series melters/applicators use standard 'meler' components. The entire range of 'MD/MDR', 'MS/MSR', 'ND' and 'NDS' hoses and guns may be connected to this equipment.

Up to six hose-gun outputs may be connected to 4, 8 and 16L 'micron gear' melters/applicators, depending on the number of pumps installed.

Warning: When connecting hose-gun outputs, verify that the connected power is not above the maximum allowable power for each output.

The 'micron gear' series melting equipment is equipped with a hydraulic distributor for each pump, with 3 possible outputs, depending on the connections that will be used. Connect the hoses to the distributor according to the needs of the installation and the ease of connection.

Caution:

- In order to identify each hose-gun, electrically connect them to the connector with the same number as the output they use.
- It is preferable to use couplings at a 90° angle to minimize the space the hoses occupy. Using straight couplings usually results in curves with very small radii that may damage the inside of the hose.
- Save the screw-on caps that are removed from the distributor in order to connect a hose. They may be necessary in the future if a hose is removed from its location.
- Perform the electrical hose and gun connections with the equipment turned off. Failing to do so may result in electrical defects in the connection and the appearance of alarm messages on the melter/applicator display.

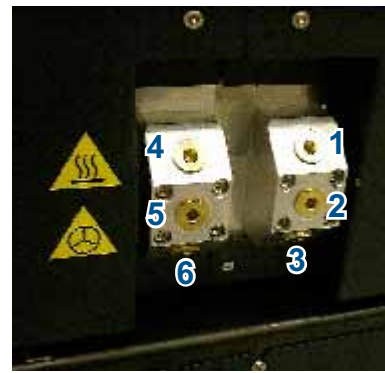

Parameter Programming

Once the melter/applicator and its components are installed, you will need to program the operational parameters appropriate for the specific application that will be performed.

'micron gear' series melters/applicators simplify this task as much as possible, allowing the operator to modify only those parameters that are necessarily variable for each application.

Among the various parameters, it is necessary to program the set point temperature values for each component connected and the value for overheating warnings. There are two other parameters (weekly start-up and shut-down programming and the standby temperature value) left to program in advanced systems, although the factory default values are perfectly valid for operational purposes.

Programming working temperatures

The melters/applicators leave the factory with the following set point temperatures:

- 160 °C (320 °F) for the tank and the distributor
- Disconnected (OFF) for hoses and guns

The general process for modifying set up temperature values for any component is described below.

1. Select the component for which you wish to modify the value with the left-right arrow.

The corresponding LED will blink quickly.

2. Using the up-down arrow, select the desired value for the set point temperature.
3. After ten seconds, the LED will stop blinking and the display will change by default to the set point temperature, saving the changed data.

This simple process must be repeated for each one of the components installed on the melter/applicator.

Selecting the overheating value

1. Press the buttons with the clock symbol and the down arrow at the same time to enter the special menu

The choice of display units (°C or °F) will appear on the display.

2. Using the right arrow, we advance to the next screen where the overheating symbol appears. **— — —**
3. Select the desired value with the up-down arrow.

The value displayed corresponds to the increase in real temperature over the set point temperature permitted without activating the alarm message.



4. Use the right arrow to advance to the next screen.
5. Exit the special menu using the left arrow and the tank temperatures will once again be displayed.

All the special menu values will be saved.

Keeping a component on display

By default, the main display shows the tank temperatures. However, it is possible to display indefinitely the temperatures of any component for analysis or tracking.

1. Select the component you wish to see permanently with the left-right arrow.

The corresponding LED will blink rapidly.

2. Hold the arrow button down for two seconds, selecting the desired component.
3. The display will now remain on the selected component, without changing.
4. Simple press any left-right arrow button again to restore the default display (tank).



External I/O connections

The melter/appliator's input and output signals (I/O) allow it to communicate with the main machine simply and directly.

There are four signals that may be used to communicate with the main machine:

- **Temperatures ok**_an output from a non-voltage contact that communicated to the main machine (or to a warning light beacon) that all the system temperatures have reached 3° below their set point value (and the delay time have finished) during start-up, or that their real value is not 20°C below their set point value during operation.
- **External Standby**_control input from the standby mode, via a non-voltage contact. The standby function is connected with a closed contact; an open contact disconnects it.
- **Low level**_an output from a non-voltage contact that communicates to the main machine (or to a warning light

beacon) that the adhesive fluid level in the tank has reached the minimum level established (optional)

- **Output inhibitor_inhibitor** tracking inputs for each hose-gun output via a non-voltage contact. With a closed contact, the output remains activated; with an open contact, it is deactivated.
- **Motor start up**_for each pump installed, the motor start up may be controlled by closing an external non-voltage contact.
- **Motor speed set point**_for each pump installed, the rotational speed of the motor (and therefore, the pump) may be controlled by means of a 0 to 10V DC external signal.



Warning: Risk of electric shock. Carelessness may cause injuries or death.

Temperature ok



1. If only this signal will be connected, use a 0.5 mm² two-wire cable.

Install an electrical wall bushing Pg9 on the equipment base plate next to the electrical supply input.



2. Open the door to the electrical cabinet as far as possible. Thread the power cord (Ø4-8 mm) through the electrical wall bushing Pg9 and fasten it to the inside anchor, making sure that the cord reaches the power card connector at the position where it will be installed.

3. Remove the connector from the card and connect the two cable wires to their corresponding connector terminals:

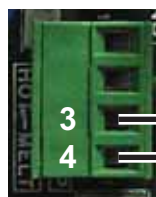

3 contact NO
4 contact NO



4. Reconnect the card connector
5. Make sure that the cable is well connected and that its path through the electrical cabinet presents no risks of snagging, being cut or any other accidental deterioration.



Warning: It must be connected to 24 AC or DC voltage. If you connect this signal to 230V load current cannot be less than 50mA.

External Standby

1. If this is the only signal being connected, use 0.5 mm² two-wire cable.

Install an electrical wall bushing Pg9 on the equipment base plate next to the electrical supply input.



2. Open the door to the electrical cabinet as far as possible. Thread the power cord (Ø4-8 mm) through the electrical wall bushing Pg9 and fasten it to the inside anchor, making sure that the cord reaches the power card connector at the position where it will be installed.



3. Remove the connector from the card and connect the two cable wires to their corresponding connector terminals:

- 1 contact NO
- 2 contact NO

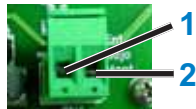

4. Reconnect the card connector

5. Make sure that the cable is well connected and that its path through the electrical cabinet presents no risks of snagging, being cut or any other accidental deterioration.

Low level (optional)

1. If this is the only signal being connected, use 0.5 mm² two-wire cable.

Install an electrical wall bushing Pg9 on the equipment base plate next to the electrical supply input.



2. Open the door to the electrical cabinet as far as possible. Thread the power cord (Ø4-8 mm) through the electrical wall bushing Pg9 and fasten it to the inside anchor, making sure that the cord reaches the power card connector at the position where it will be installed.



3. Remove the connector from the card and connect the two cable wires to their corresponding connector terminals:

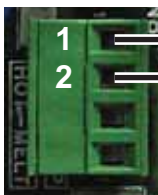

- 1 contact NO
- 2 contact NO



4. Reconnect the card connector

5. Make sure that the cable is well connected and that its path through the electrical cabinet presents no risks of snagging, being cut or any other accidental deterioration.



Warning: It must be connected to 24 AC or DC voltage. If you connect this signal to 230V load current cannot be less than 50mA.

Output inhibitor

1. If this is the only signal being connected, use a seven-wire cable no smaller than 0.22 mm².

Install an electrical wall bushing Pg9 on the equipment base plate next to the electrical supply input.

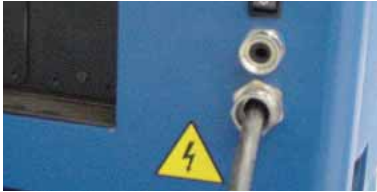

2. Open the door to the electrical cabinet as far as possible. Thread the power cord (Ø4-8 mm) through the electrical wall bushing Pg9 and fasten it to the inside anchor, making sure that the cord reaches the power card connector at the position where it will be installed.



3. Remove the connector from the card and connect the two cable wires to their corresponding connector terminals:

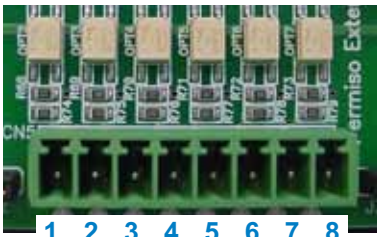

- 1 common + voltage output
- 2 input for inhibitor output 1
- 3 input for inhibitor output 2
- 4 input for inhibitor output 3
- 5 input for inhibitor output 4
- 6 input for inhibitor output 5
- 7 input for inhibitor output 6
- 8 without connection

4. Reconnect the card connector

5. Make sure that the cable is well connected and that its path through the electrical cabinet presents no risks of snagging, being cut or any other accidental deterioration.

It is possible to select the channels that you want to control from the outside using the small switches located above the connector. Switches 1 through 6 control each of the channels, so that the switch in the 'ON' position means heating from the equipment, without any external control.



When the switch is in the 'OFF' position, the corresponding channel does not heat unless activated from the outside, through a non-voltage contact between pin 1 (the common pin) and the pin that corresponds to the channel.

Starting up the motor

1. If only this signal is going to be wired, use a two-wire 0.5 mm² section cable.

Install a Pg9 electrical wall bushing in the plate at the base of the equipment, next to the electrical power intake.

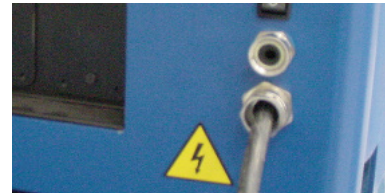

2. Open the door to the electrical cabinet as far as possible. Run the signal cable (Ø4-8 mm) through the Pg9 bushing and attach it to the inside anchor, making sure that the cable reaches the terminals on the inside, next to the motor variator.

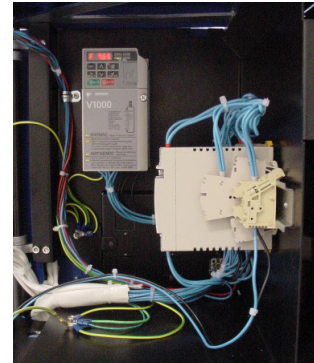

3. Connect the two wires from the start-up signal to the terminals XC1 and XC2. This is a double terminal, which makes it necessary to connect each wire in one of the two holes in the terminal. Since this contact is not under voltage, there is no connection polarity.

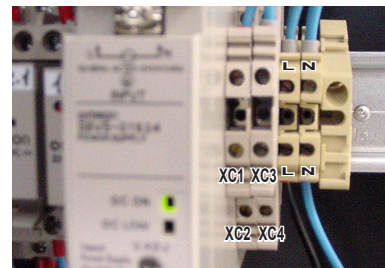

4. Make sure that the cables are firmly attached by the terminal screws.
5. For the signal to work, the switch on the control panel must be in the 'AUTO' position.

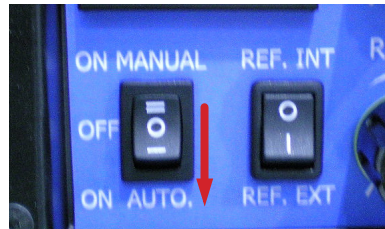

Motor speed set point reference

1. If only this signal is going to be wired, use a two-wire 0.5 mm² section cable.

Install a Pg9 electrical wall bushing in the plate at the base of the equipment, next to the electrical power intake.

2. Open the door to the electrical cabinet as far as possible. Run the signal cable (Ø4-8 mm) through the Pg9 bushing and attach it to the inside anchor, making sure that the cable reaches the terminals on the inside, next to the motor variator.



3. Connect the two wires from the start-up signal to the terminals

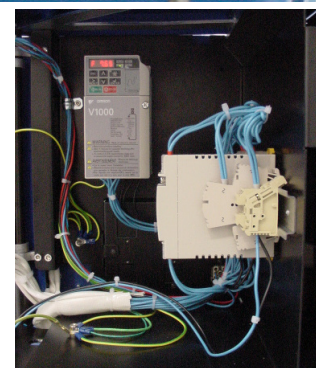

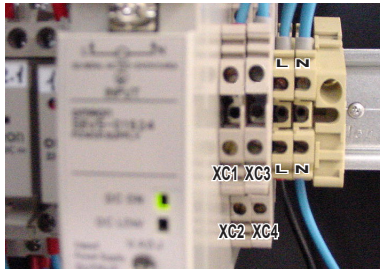

XC3 and XC4. This is a double terminal, which makes it necessary to connect each wire in one of the two holes in the terminal. The positive signal wire must be connected to point XC4 of the terminal, while the negative wire must be connected to point XC3.

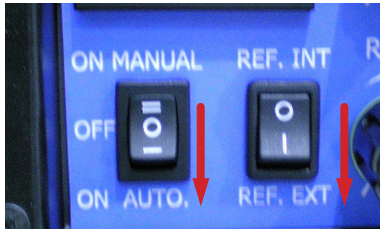

4. Make sure that the cables are firmly attached by the terminal screws.
5. For the signal to work, the switches on the control panel must be in the 'AUTO' and 'EXT' positions.



This page is intentionally left blank.

4. MELTER OPERATION

In this section we will introduce the method for using the melter/ applicator. Although its operation is very simple, it should not be used by untrained personnel.



Warning: Improper use may cause damage to the machine or injury and even death to the person using it.

General information

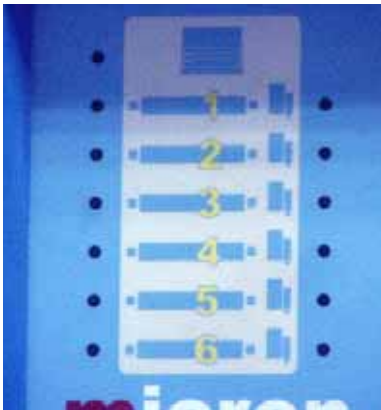

There are three large groups of components with thermal control in a hot-melt installation: the fusion unit, the transport hoses and the melter/applicator guns. All of these are controlled from the front panel of the melter/applicator equipment.

The first large group is the tank-distributor assembly. For a single installed pump, they form a single unit, with separate controls, even though their set point value is the same. Therefore, when you program a value for the tank, for example 170°C, the distributor takes on this same value. If two pumps are installed, the distributors occupy channels 1 and 2 with set point values and control that are independent to the tank and to each other.

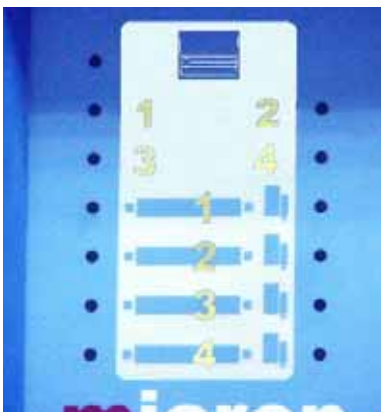

The second group is the hose group. These are identified on the front panel from No. 1 to No. 6, depending on the model, for a single installed pump (No. 1 to No. 4 for two pumps), and by a picture of the corresponding hose. Each has its own set point value.

The third group is the gun group. These are identified on the front panel from No. 1 to No. 6, depending on the model, for a single installed pump (No. 1 to No. 4 for two pumps), and by a picture of the corresponding gun. Each has its own set point value.

The hose and gun numbers are automatically assigned to the hose/ gun channel they are connected to on the rear part of the melter/ applicator.

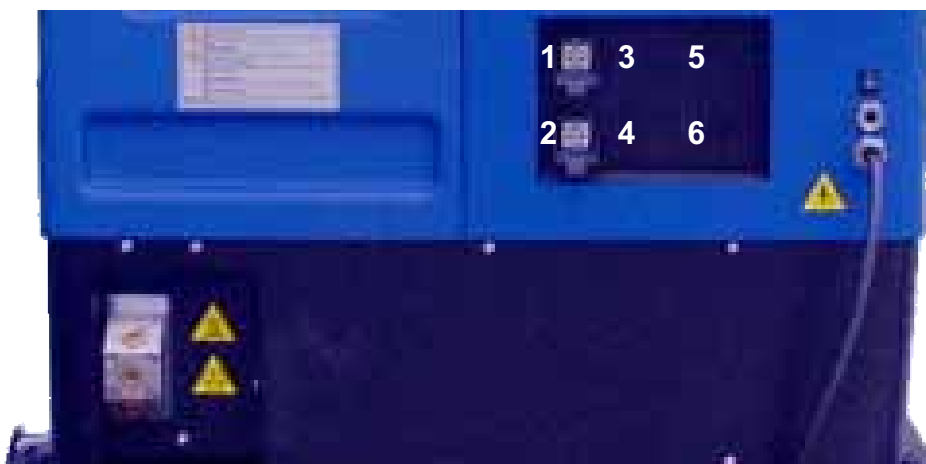

Filling the tank

The tank can be equipped with a floating-type low level sensor (optional) that warns when the level of hot-melt adhesive drops below a third of the tank's capacity.

The unit will activate the external signal and, if it is connected, the corresponding warning device.

Warning: Before refilling the tank, make sure that the adhesive is the same type as that already in the tank. Mixing different types of adhesives can cause damage to the melter/appliator equipment.



To fill the tank:

1. Open the tank lid
2. Use a shovel or a ladle to fill the tank with adhesive. Do not fill the tank above the loading opening level. The lid must be able to close normally.

Warning: Risk of burns. Always refill using protective gloves and glasses.



3. Close the lid when you have finished refilling the tank.

MODEL	CAPACITY	
micron4	4 L	4 kg
micron8	8 L	8 kg
micron16	16 L	16 kg

For a density of 1g/cc



Starting up the melter/appliator equipment

Before starting up the melter/appliator equipment, it is necessary to check to see if the unit has been correctly installed and all its input/output and accessory connections are correctly established.

It is also necessary to make sure that the equipment has been filled with adhesive and that the operational parameters have been programmed.



To start:

1. Connect the melter/appliator's switch.

If the control card was turned off the last time the machine was disconnected, it will remain tuned off when the machine is started up again (time display).

If the control card was on the last time that the machine was disconnected, it will turn on when the machine is started up again.



2. Press the ON/OFF button on the control card to turn it on, if it not already activated.

By default, the set point and real temperature values shown are those corresponding to the tank.

The tank heating control LED (green) will light up and the tank will begin to heat.



Once it has reached 3° below the programmed temperature (set point) of the tank, a programmable delay timer starts until, guaranteeing fusion, the pump receives permission to operate and the signal will be sent to the main machine, indicated by the two corresponding (green) LEDs.



While the system is running the delay timer both LEDs remains blinking until the programmed time value has been reached. If then, any other element has not reached 3° below its temperature setting point, the LEDs turn off.

If the system is shut down, for any possible mode, when it is turning on the delay timer only starts again if the tank temperature is 20° below setting point.



3. Make sure that the control switches for each of the motors installed is in the correct position (see Chapter '2. Introduction. Operating modes').

Melter/appliator equipment displays

'micron gear' series melters/appliators have two displays built into their control panel, with three sets of 7 segments each for displaying the temperature values (set point and real temperature), programmable parameters and alarms.



They are equipped with LED indicators to display the heating of each component, as well as the pump activations and the main machine connection signal.

LED display	Component heating	Component status
constantly lit	constant	low temperature
blinking slowly	as needed (according to PID parameters)	temperature near set point
blinking rapidly	programming or display	change in set point values
off	not heating	temperature reached

They are also equipped with LEDs indicating equipment connection/disconnection and standby function connection/disconnection:

Led display	On/off	Standby
constantly lit	turned off unit	function activated
blinking slowly	deactivation programmed for the current day	activation programmed for the current day
blinking rapidly	activation/deactivation programming mode	activation/deactivation programming mode
off	unit in operation	function deactivated
simultaneous intermittence from both leds	timing in progress, once the tank has reached its set point temperature	



Displaying the temperature for each component

The temperature may be displayed for each component (tank, distributor and each hose and gun) by selecting the component with the cursor.

Press the left-right arrow until the desired component is displayed.

After 10 seconds, the display will return to the default component (the tank).

If you wish to keep the component displayed permanently, press and hold the left-right arrow for 2 seconds while selecting the chosen element.

For units that have one pump installed, the display sequence is the following:

distributor←tank←hose1←gun1←...←hose6←gun6
 distributor→tank→hose1→gun1→...→hose6→gun6



For units that have two pumps installed, the display sequence is the following:

```

null<—tank<—distributor1<—Off<—distributor2<—Off<—hose 1
      <—gun1<—...<—hose4<—gun4
null—>tank—>distributor1—>Off—>distributor2—>Off—>hose 1
      —>gun1—>...—>hose4—>gun4
    
```

To remove a component from permanent display, simply press either of the left-right arrows.



Alarm displays

'micron' series melter/appliator equipment tell the user when a malfunction has occurred in the unit, sending warning messages that may be seen on the control panel display.

code	source	actions			
		heating	pump	main machine signal	
Err 0	tank broken sensor	only tank off	off	off	One pump installed
Err 1	hose1 broken sensor	only hose1 off	off	off	
Err 2	gun1 broken sensor	only gun1 off	off	off	
Err 3	hose2 broken sensor	only hose2 off	off	off	
Err 4	gun2 broken sensor	only gun2 off	off	off	
Err 5	hose3 broken sensor	only hose3 off	off	off	
Err 6	gun3 broken sensor	only gun3 off	off	off	
Err 7	hose4 broken sensor	only hose4 off	off	off	
Err 8	gun4 broken sensor	only gun4 off	off	off	
Err 9	hose5 broken sensor	only hose5 off	off	off	
Err 10	gun5 broken sensor	only gun5 off	off	off	
Err 11	hose6 broken sensor	only hose6 off	off	off	
Err 12	gun6 broken sensor	only gun 6 off	off	off	
Err 13	distributor broken sensor	only distributor off	off	off	
Err 100	tank overheating	all components off	off	off	
Err 101	hose1 overheating	all components off	off	off	
Err 102	gun1 overheating	all components off	off	off	
Err 103	hose2 overheating	all components off	off	off	
Err 104	gun2 overheating	all components off	off	off	
Err 105	hose3 overheating	all components off	off	off	
Err 106	gun3 overheating	all components off	off	off	
Err 107	hose4 overheating	all components off	off	off	
Err 108	gun4 overheating	all components off	off	off	
Err 109	hose5 overheating	all components off	off	off	
Err 110	gun5 overheating	all components off	off	off	
Err 111	hose6 overheating	all components off	off	off	
Err 112	gun6 overheating	all components off	off	off	
Err 113	distributor overheating	all components off	off	off	

When an alarm appears, the control unit takes a series of steps to protect the unit. Simply correct that malfunction and the control unit will reactivate the equipment functions.

code	source	actions			
		heating	pump	main machine signal	
Err 0	tank broken sensor	only tank off	off	off	Two pumps installed
Err 1	distributor1 broken sensor	only distributor1 off	off	off	
Err 2	null				
Err 3	distributor2 broken sensor	only distributor2 off	off	off	
Err 4	null				
Err 5	hose1 broken sensor	only hose1 off	off	off	
Err 6	gun1 broken sensor	only gun1 off	off	off	
Err 7	hose2 broken sensor	only hose2 off	off	off	
Err 8	gun2 broken sensor	only gun2 off	off	off	
Err 9	hose3 broken sensor	only hose3 off	off	off	
Err 10	gun3 broken sensor	only gun3 off	off	off	
Err 11	hose4 broken sensor	only hose4 off	off	off	
Err 12	gun4 broken sensor	only gun4 off	off	off	
Err 13	tank2 broken sensor				
Err 100	tank overheating	all components off	off	off	
Err 101	distributor1 overheating	all components off	off	off	
Err 102	null				
Err 103	distributor2 overheating	all components off	off	off	
Err 104	null				
Err 105	hose1 overheating	all components off	off	off	
Err 106	gun1 overheating	all components off	off	off	
Err 107	hose2 overheating	all components off	off	off	
Err 108	gun2 overheating	all components off	off	off	
Err 109	hose3 overheating	all components off	off	off	
Err 110	gun3 overheating	all components off	off	off	
Err 111	hose4 overheating	all components off	off	off	
Err 112	gun4 overheating	all components off	off	off	
Err 113	tank2 overheating				

Standby function does not generate any alarm.

If a temperature sensor is broken, the system heats all the elements except the one where the failure is located.

In case of overheating the system cuts off immediately the damaged element. After three minutes if the failure continues all the system will be shut down. After repairing the failure the system starts heating normally.

Hot-melt display level (optional)

When the level of hot-melt drops below 1/3 of the tank capacity, the level detector sends a signal to the melter/applicator control unit, which takes the following actions:

On-screen display (if the function is activated)





It closes a non-voltage output contact where the user will install the required device (horn, light or PLC input).

Simply refill the tank and wait for the adhesive to melt enough that the sensor sends the message that the correct level has been reached.

Operating speed display and adjustment



The speed at which the pump turns (in revolutions per minute) is shown on the control display for each motor in the unit. These revolutions may be adjusted using the potentiometer labeled 'R.P.M.' Turning clockwise increases the revolutions, while turning counterclockwise reduces the revolutions. La velocidad de giro de la bomba debe ser ajustada a las necesidades de la aplicación.



Warning: Even though the control allows you to select rotational speeds between 0 and 100 rpm, it is not recommended to work at speeds below than 10 rpm (the flow might not be constant, depending on the motor load) or above 80 rpm (with the pump operating at maximum revolutions).



Under the rotational speed adjustment potentiometer, we find the maximum speed control, labeled as 'RATIO.' This potentiometer allows us to adjust the full scale of the speed adjustment as a percentage, so that the maximum adjusted speed is 100 rpm (100%) or lower. This regulation affects both the manual speed adjustment and the external set point value for automatic adjustments.

Temperature adjustment

The melters/applicators leave the factory with the following set point temperature values:

- 160 °C (320 °F) for the tank and distributor
- Disconnected (OFF) for the hoses and guns
- °C displayed
- Overheating value: 25°C
- Standby value: 55%
- Delay time: 10 min
- On/off and stanby programming: OFF
- Low level detector: OFF

The general process for adjusting the temperatures of each components is described below.



1. Select the component whose value you wish to modify using the left-right arrow. The tank and the distributor have the same set point value.

The corresponding LED will blink rapidly.

2. Select the desired set point temperature value with the up-down arrow. Below 40°C the set point value displays 'OFF' canceling the heating of that element.
3. After ten seconds, the LED will stop blinking and the display will show the tank's set point temperature value by default, saving the modified data.

This simple procedure should be repeated for each of the components whose set point temperature value you wish to modify.

Programming the applicator parameters

1. Simultaneously press the buttons with the clock symbol and the down arrow to enter the special menu.

The choice of temperature display units (°C or °F) will appear on the display.

2. Select the desired value using the up-down arrow.
3. Use the right arrow to move to the next display where the overheating symbol appears. **— — —**
4. Select the desired value (between 10 and 25) using the up-down arrow.

The value shown corresponds to the increase in real temperature allowed over the set point temperature without activating the alarm message.

5. Use the right arrow to go to the next display where the standby function symbol appears. **— — —**
6. Use the up-down arrow to select the desired value (between 25 and 55).

The value shown corresponds to the percent decrease in the real temperature compared to the set point temperature that will occur when this function is activated.

7. Use the right arrow to go to the next display where delay time value appears.
8. Use the up-down arrow to select the desired value (between 0 and 60 min).
9. Use the right arrow to advance to the next screen, where the

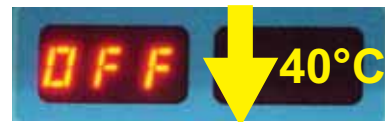



level detector activation/deactivation is found.

10. Use the up-down arrow to select the desired value (ON/OFF). When OFF is selected, neither the on-screen display nor the external signal activation will be operational. If ON is selected, when the level of hot-melt is low the alarm (n - - -) will be displayed on the screen and the external signal contact will be activated.
11. Use the right arrow to return to the initial parameter.
12. For any parameter, the left arrow may be used to exit the special menu and display the tank temperatures once again.

To record any parameter, you must always move to the next parameter, using the right arrow.

Setting the clock

'micron gear' series melters/applicators are equipped with a weekly programmable system controlling equipment connection and disconnection and activating and deactivating the standby function.

Before programming these functions, it is necessary to introduce into the control unit data corresponding to the day and hour used to execute these programs.



Programming the current day and hour

1. Press the button with the clock symbol.

A '0' will appear on the display, indicating the program for current day and hour information.

2. Press the button with the clock symbol once again.

On the left display, you will see the time with a dot, indicating that this is the value that may be modified, while the minutes appear on the second display.

3. Use the up-down arrow to select the desired value.
4. Press the button with the clock symbol once again.

Now the dot will appear on the right display.

5. Use the up-down arrow to select the desired value.
6. Press the button with the clock symbol once again.

A number appears, indicating the day of the week (1- Monday / 7- Sunday).

7. Use the up-down arrow to select the desired value.
8. Press the button with the clock symbol once again.

The '0' program appears once again.

9. Pressing either the left or the right arrow button will exit this program and return to the tank temperature display.



Programming equipment activation/deactivation

You may program an activation and a deactivation time for every day of the week, from Monday (1) to Sunday (7).

Time is expressed in 15 minute increments, so we cycle from 10.0 (10 hours and 0 minutes) to 10.1 (10 hours and 15 minutes) to 10.2 (10 hours and 30 minutes) to 10.3 (10 hours and 45 minutes).

1. Press the button with the clock symbol

A '0' will appear on the display, indicating the program for current day and hour information.

2. Use the up-down arrow to select the value for the desired day of the week, from Monday (1) to Sunday (7).

3. Press the button with the clock symbol once again.

Two times will appear, one in each display. The display on the left shows the start time, while the display on the right shows the finish time.

4. The blinking dot next to the start time indicates that this is the value that may be modified. Use the up-down arrow to select the desired value.

5. Press the button with the clock symbol once again.

The dot changes to the finish time.

6. Use the up-down arrow to select the desired value.
7. Press the button with the clock symbol once again.



The selected program will appear once again. Use the up-down arrow to select other programs.

- Pressing either the left or the right arrow button will exit this program and return to the tank temperature display.

The green LED next to the 'ON/OFF' button will remain blinking as long as there is an equipment disconnection time programmed for the current day.



Disabling the equipment activation/deactivation program

It is possible to disable the equipment activation/deactivation programming without canceling the daily programming. This way the programmed data is saved, but the programming will have no effect on the equipment.

- Press the button with the clock symbol.

A '0' will appear on the display, indicating the program for current day and hour information.

- Use the up-down arrow to go past the selection for the last day of the week (7).

The message 'ON/OFF' will appear on the display, depending on the current status.

- Press the button with the clock symbol once again.

The status will alternate each time you press the button.

- Pressing either the left or the right arrow button will exit this program and return to the tank temperature display.

Programming the equipment's standby function activation/deactivation

You may program an activation and a deactivation time for every day of the week, from Monday (1) to Sunday (7).

Time is expressed in 15 minute increments, so we cycle from 10.0 (10 hours and 0 minutes) to 10.1 (10 hours and 15 minutes) to 10.2 (10 hours and 30 minutes) to 10.3 (10 hours and 45 minutes).

- Press the button with the clock symbol.

A '0' will appear on the display, indicating the program for current day and hour information.



2. Press the standby function button.

A '1' will appear, indicating the first day in the standby function programming.

[Since the current time and date are values common to both programs, the value '0' does not appear in this menu].

3. Use the up-down arrow to select the desired value for the day of the week, Monday (1) to Sunday (7).

4. Press the button with the clock symbol once again.

Two times will appear, one in each display. The left display shows the start time, while the right display shows the finish time.

5. The blinking dot next to the start time indicates that this is the time that may be modified.

Use the up-down arrow to select the desired value.

6. Press the button with the clock symbol once again.

The dot changes to the finish time.

7. Use the up-down arrow to select the desired value.

8. Press the button with the clock symbol once again.

The selected program appears once again. You may use the up-down arrow to select other programs.

9. Pressing either the left or the right arrow button will exit this program and return to the tank temperature display.

The green LED next to the 'standby' button will remain blinking as long as there is an equipment standby function activation time programmed for the current day.

Disabling the equipment standby function programming

It is possible to disable the equipment standby function programming without canceling the daily programming. This way the programmed data is saved, but the programming will have no effect on the equipment.



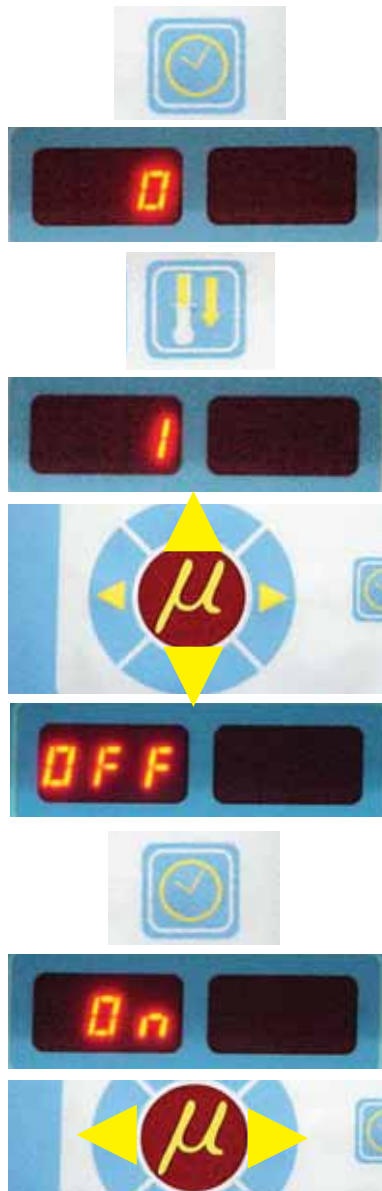

1. Press the button with the clock symbol.

A '0' will appear on the display, indicating the program for current day and hour information.

2. Press the standby function button.

A '1' will appear, indicating the first day in the standby function programming.

3. Use the up-down arrow to go past the selection for the last day of the week (7).

The message 'ON/OFF' will appear on the display, depending on the current status.

4. Press the button with the clock symbol once again.

The status will alternate each time you press the button.

5. Pressing either the left or the right arrow button will exit this program and return to the tank temperature display.

Special function buttons

The simplicity of programming '*micron gear*' series melters/ applicators reduces the use of the special function buttons to only the standby function.

This manual function allows you to alternate between the operational mode and the standby mode. Using the standby function during periods of melter/applicator inactivity helps save energy and allows the heated elements to return quickly to their set point temperatures once you return to the operational mode.

When the standby function is activated, the set point temperature for all the heated components is lowered to a certain value,



according to the programmed parameter (see '*Programming melter/applicator equipment parameters*'). For example, if the tank set point temperature is 160 °C and the standby temperature is programmed as 30 (30%), when you press the standby function button, the tank set point temperature will drop to 112 °C (70% of 160 °C).



The three means for activating the standby function available with 'micron' melters/applicators have the following priority protocols:

- 1° manual standby function button
- 2° standby function external signal
- 3° standby function activation/deactivation programming

Therefore, if the function is activated by any of the three means, it may always be deactivated using the manual button. On the other hand, if it was activated using the manual button, it may not be deactivated by either of the other two means. The weekly programming may not deactivate a standby function that has been activated by either of other two means.

The following criteria are suggested for standby function use:

- If the period of inactivity is less than 2 hours, allow the melter applicator equipment to heat as normal.
- If the period of inactivity is more than 2 hours and less than 4 hours, use the standby function.
- If the period of inactivity is over 4 hours, use one of the following two options: turn off the equipment if you do not plan on using it for the rest of the day or keep the standby function on if you plan on using the equipment during that same day.

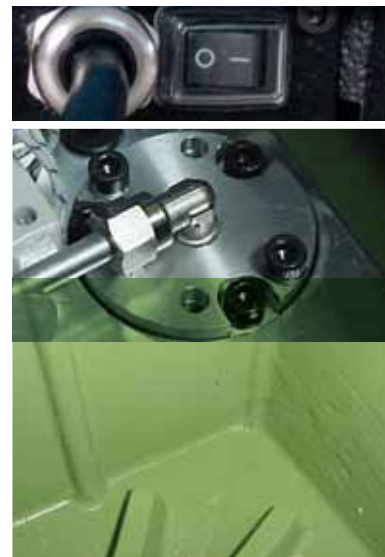

Pump speed control

Manual mode

The manual operating mode provides total user control over start-up/stop and the pump rotational speed adjustment.

To operate in this mode, follow these steps:

1. Set the 'ON-OFF' switch to the 'MANUAL' position.

If there has been a previous speed adjustment made, this value will appear on the display and the pump will start to turn at the speed indicated. If this is not the case:





2. Turn the 'R.P.M.' control clockwise and the pump will begin to turn at the revolutions indicated on the display.

3. Set the rotational speed to the value needed for the application.

The full scale for this control is the maximum number of revolutions permitted, 100, although it is recommended to work at speeds that are neither below 10 rpm nor above 80 rpm.

This full scale may be varied using the control labeled 'RATIO,' which reduces this value percentage wise. Therefore, with the 'RATIO' control at the middle position, the maximum value that can be reached using the 'R.P.M.' control is only 50 rpm.



Automatic mode with an internal set point signal

This operating mode permits the user to control the pump rotational speed, but leaving the start-up/stop dependent on an external signal (a contact that is not under voltage), normally from the main machine.

To operate in this mode, follow these steps:

1. Set the 'REF' switch to the 'INT' position.
2. Set the 'ON-OFF' switch to the 'AUTO' position.

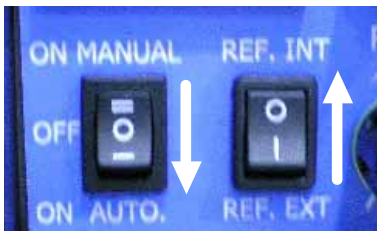

The system will wait for the start-up signal from the main machine. When this is received, if there has been a previous speed adjustment made, this value will appear on the display and the pump will start to turn at the speed indicated. If this is not the case:

3. Turn the 'R.P.M.' control clockwise and the pump will begin to turn at the revolutions indicated on the display.

4. Set the rotational speed to the value needed for the application.

The full scale for this control is the maximum number of revolutions permitted, 100, although it is recommended to work at speeds that are neither below 10 rpm nor above 80 rpm.

This full scale may be varied using the control labeled 'RATIO,' which reduces this value percentage wise. Therefore, with the 'RATIO' control at the middle position, the maximum value that can be reached using the 'R.P.M.' control is only 50 rpm.



Automatic mode with an external set point signal

This operating mode allows the main machine to have total control

over the pump start-up/stop (through a contact that is not under voltage) and the pump rotational speed control (by means of a 0-10V DC external signal under voltage).

To operate in this mode, follow these steps:

1. Set the 'REF' switch to the 'EXT' position.
2. Set the 'ON-OFF' switch to the 'AUTO' position.

The system will wait for the start-up signal from the main machine. When this is received, if there a previous voltage signal has been received, the corresponding speed value will appear on the display and the pump will start to turn at the speed indicated. If this is not the case:

3. Start the main machine so that it sends the appropriate voltage signal.
4. Set the signal to the value needed for the application.

A 10 V DC signal for the speed set point corresponds to the maximum number of revolutions permitted, 100, although it is recommended to work at speeds that are neither below 10 rpm nor above 80 rpm.

The correspondence between the voltage and the rotational speed may be varied using the control labeled 'RATIO,' which reduces this value percentage wise. Therefore, with the 'RATIO' control at the middle position, the maximum value that can be reached at 10V DC is only 50 rpm.

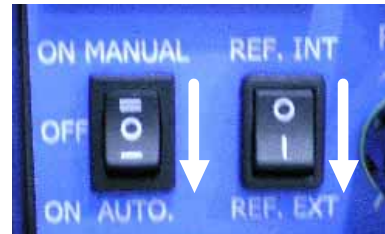

By-pass valve regulation

The pumping system using a geared pump provides a constant flow of adhesive, according to the pump's rotational speed.

In this type of system, the pressure generated by the pump is the result of the retentions found on the circuit (the length and diameter of the hose, elbows in the connectors, the diameters of the nozzle outputs, etc.) and the adhesive itself (its viscosity).

For safety reasons, this pressure must be discharged when the circuit exceeds the operating value (normally with a closed circuit and the pump activated), which makes the use of a discharge valve or a by-pass valve necessary.

This valve may be a manual adjustment valve, using a threaded screw, or upon request, with pneumatic control, using a pressure regulator and a pressure gauge. In the latter case, the adhesive

circuit pressure has a 15:1 ratio to the pressure displayed on the pressure gauge.

Manual valve control



To adjust the pressure with this valve model (in an approximate manner), follow these steps:

1. Screw the spindle in clockwise, as far as possible. In this position, the maximum pressure is 90 kg/cm².
2. Gradually loosen by turning counterclockwise until reaching the desired pressure. Each millimeter that the spindle sticks out represents a reduction of approximately 9 kg/cm².



Pneumatic valve control

To adjust the pressure with this valve model, follow these steps:

1. Unlock the pressure regulator control by pulling on it gently.

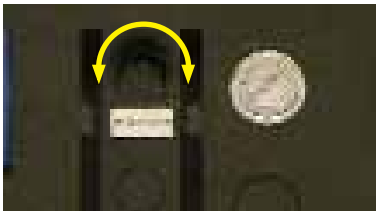

2. Turn it clockwise to increase the pressure. This will be seen reflected on the pressure gauge located next to it.



Warning: Do not exceed 6 bar of pressure. This corresponds to 90 kg/cm² on the hydraulic circuit.

Turning off the melting equipment

If it is necessary to disconnect the melting equipment:

1. Switch each motor control installed on the unit to the 'OFF' position.
2. Disconnect the equipment switch located at the rear, next to the power intake.



3. Reduce the by-pass valve pressure to 0, if it is pneumatically controlled.
4. Disconnect the pneumatic power supply from the guns and the electrical power supply from the control programmer, if there is one.



Using the air drying system

Polyurethane-based reactive adhesives, known as P.U.R. (reactive polyurethanes), require a completely dry environment before they can be applied, since when they come in contact with atmospheric humidity, they reticulate, hardening quickly.

As an option, 'micron gear' series melting equipment ensures a dry environment thanks to the addition of an air-drying system to these models, which provides a level of dehumidification above 99.98%. This guarantees that the adhesive is preserved without premature reticulations inside the applicator unit.

The metering unit consists of a pressure regulator, a by-pass electrovalve with its corresponding pipe to the inside of the unit tank and a timer that controls the electrovalve. The system connections may be seen in Chapter '7. Electrical diagrams'.

This system uses a timer for dosing with a continuous cycle, which allows us to program the standby time (between one injection and the next), as well as the injection time. The values set in the factory are 10 min for standby time and 10 s for injection. A pneumatic pressure of 0.5 kg/cm² is recommended.



1. Time margin for the first circuit timer tripping the activation relay.
2. Absolute scale for precise adjustment of the first timer circuit.
3. Find adjustment of time delay.
4. Time delay range.
5. LEDs indicating the operation status.
 - Un Power voltage (green)
 - R Relay activated (yellow)

Green LED: flashes during the time delay period, permanently on outside the time delay period.

Yellow LED: on when relay is energized.

6. Contact diagram (on the side)
 - B1/A2 Power (24V DC)
 - 15/16/18 Relay contact switch (15: common/16: NC/18: NO)

Time scales:

0.05-1 s	15-300 s
0.15-3 s	1.5-30 min
0.5-10 s	1-300 min
1.5-30 s	1.5-30 h
5-100 s	15-300 hcm2.

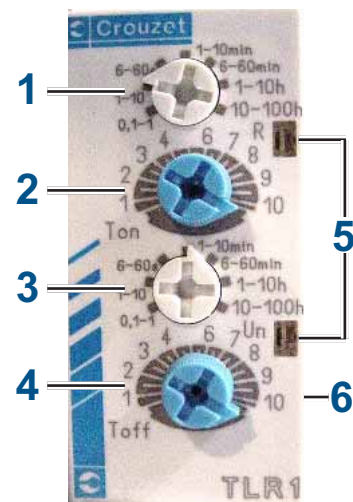



After loading new adhesive or each time that the unit's tank cover is opened, we recommend using the manual injection method for approximately 60 s. To do this, activate the button on the system's electrovalve.

To maintain the air drying system in perfect condition, we recommend periodically observing the green indicator for filter saturation control. If this indicator turns red, it is necessary to replace the filter cartridges. See the corresponding chapter for replacement parts.





This page is intentionally left blank.

5. MAINTENANCE



Warning: The melter/appliator equipment is equipped with current technology, but has certain foreseeable risks. Therefore, only allow qualified personnel with enough training and experience to operate install or repair this equipment.

The following table briefly summarizes the indications for adequate melter/appliator equipment maintenance. Always read the corresponding section carefully.

If the equipment does not work or works incorrectly, called to your 'meler' Representative or to the Main Office.

Operation	Frecuency	Refer to
External cleaning	Daily	<i>Equipment cleaning</i>
System depressurization	Before performing maintenance tasks and repairing the hydraulic system	<i>Depressurizing the system</i>
Filter cleaning or changing	- As needed (once a year minimum) - With each adhesive change	<i>Filter maintenance</i>
Emptying and cleaning the tank	- When burnt adhesive is present - With each adhesive change	<i>Tank cleaning</i>
Check for pump leaks	Depending on the hours of operation and the temperature and speed parameters (min. once per month)	<i>Pump maintenance</i>
Check the lubrication (motor and gear)	Depending on the temperature and conditions of use (max. 8000 hours)	<i>Motor-gear maintenance</i>
Air dryer filters (PUR option)	- Purge water condensation (weekly) - Clean the filter (at least twice a year)	<i>Air filter maintenance</i>

Equipment cleaning

To continue to take advantage of the melter/appliator's benefits and to ensure the perfect mobility of its components, it is necessary to keep all its parts clean, especially the ventilation grate on the upper part of the machine.



Warning: Risk of electric shock. Carelessness may result in injury or death. Clean the exterior using a cloth moistened with water. Do not use flammable liquids or solvents.

External cleaning:

Use cleaning products compatible with polyamide materials.

Apply the cleaning product with a soft cloth.

Do not use sharp tools or scrapers with sharp edges.

Removing and changing exterior panels:

1. Disconnect the melter/apPLICATOR equipment.
2. Disconnect the compressed air from the equipment intake.
3. Remove the screws fastening the various side panels (A, B, C) and the upper panel (D).
4. Remove each panel sliding it in the direction shown in the figures.
5. To replace the panels, follow steps 1 through 4 in the reverse order.

[Panels A, B and C must be removed in this order and assembled in reverse order. In the case of the micron16 model, the panels surrounding the tank zone are made of sheet metal and therefore do not have any sliding anchors.]

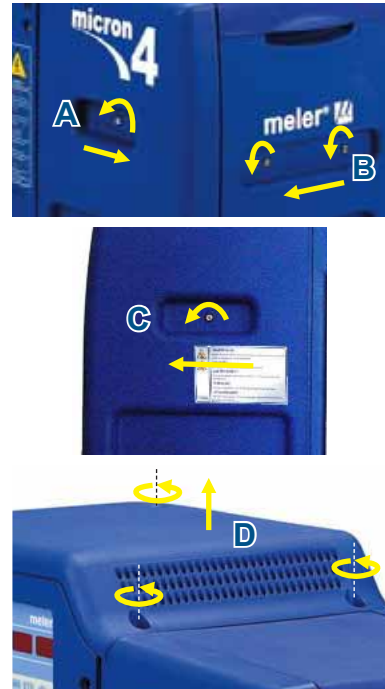

System depressurization

Melting equipment belonging to the 'micron gear' series include a safety valve (a by-pass valve) that limits the maximum pressure within the system, especially during continuous pumping periods with closed applicator guns.

However, even with the motor turned off, residual pressure may exist in the circuit. This must be kept in mind when performing any operation on the hydraulic circuit.

Before disconnecting any hydraulic element or opening any distributor outlet, it is necessary to perform the following steps:

1. Disconnect the equipment switch located on the side, next to the power intake.
2. Operate the purge valve housed in each distributor to free any residual pressure from the circuit.
3. Manually purge (or use the corresponding control command) all the guns that have been used.

Filter maintenance

'micron gear' series melter/apPLICATOR equipment is equipped with a 100 mesh pump filter. The filter prevents impurities and burnt

adhesive remains from being pushed out from the tank by the pump.



Warning: It is a good idea to also use a filter in the tank intake valve. This filter performs a first-step filtration, preventing impurities resulting from burning in the tank and other impurities that may enter from the outside from passing through.

The adhesive flows from the inside to the outside of the filter, with impurities being trapped inside it.

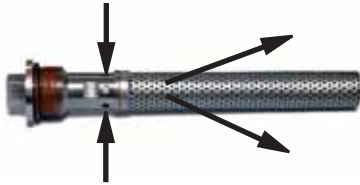

When the filter is removed from its housing, all the impurities remain trapped inside, and the inside of the distributor stays perfectly clean. The filter may be cleaned or replaced directly with a new one.

No rule exists for determining when to change the filter. Several factors influence this decision:

- the type and purity of the adhesives used
- the adhesive work temperatures
- adhesive consumption in relation to the time it spends in the tank
- changes in the type of adhesive used

In any case, we recommend checking and cleaning the filter at least every 1000 hours of operation (melter/applicator equipment turned on).



Warning: Always use protective gloves and glasses. Risk of burns.



To change the filter:

1. Close the by-pass valve from the tank to the distributor.

2. Depressurize the system using the purge valve.

3. Using a 15 mm wrench, unscrew the hexagonal filter cap and remove it.



4. Unscrew the filter cartridge in a clockwise direction.

5. Depending on the dirt inside the cartridge, clean it or dispose of it directly, abiding by any existing waste regulations.

6. Screw back the cartridge back onto the filter cap in a counterclockwise direction.
7. Replace the filter seal if damaged.
8. Place the assembly inside the distributor once more and tighten as much as possible.
9. Continue with normal operation.



Cleaning the tank

The hot-melt tank must be cleaned on occasion to maintain its fusion and anti-adherence properties. The tank is covered on the inside with PTFE and inclined enough to aid unloading the hot-melt and to avoid it from being retained inside when consequential burning occurs.

Furthermore, when adhesives are mixed, reactions may occur between them, causing a degeneration and thus problems in unloading in the direction of the pump.

Therefore, it is recommended to clean the deposit every time that:

- a change is made to a different type of hot-melt.
- too much burnt material is generated in its interior.

Changing adhesive type.

1. Use up as much of the adhesive as possible.

If it is necessary to unload the adhesive without having used it up as much as possible, follow the instructions in the section '*Emptying the tank*'.

2. Clean the remains of hot-melt adhesive on the inside of the tank.

Warning: Use appropriate protective equipment for high temperatures.



3. Add the appropriate type and quantity of the new adhesive, wait for it to melt and pump at least one full tank through the system (hoses and guns).

Cleaning burnt adhesive.

1. Empty the tank directly (see the section '*Emptying the tank*') to prevent the burnt material from passing through the pump circuit.

- Clean the adhesive remains and burnt material inside the tank. Do not use sharp objects that might damage the inside coating.



Warning: Use appropriate protective equipment for high temperatures.

- Add the appropriate type and quantity of adhesive and wait for it to melt.
- Remove the filter cartridge and clean it, if necessary (see the section '*Filter maintenance*').
- Reassemble the filter without the cartridge.
- Pump a minimum of one tank through the distributor output marked number 1.
- Remove the filter and attach it to the corresponding cartridge. Reinstall it in the distributor.
- Refill the tank with adhesive, wait for it to melt and continue working as usual.



Warning: Whenever you handle the filter or any other element subject to pressure, you must always perform a system depressurization first (see the corresponding section)

Emptying the tank

During normal maintenance activities, it is recommended, and sometimes necessary to empty the tank directly, without passing the adhesive through the pump system.

To do so, follow these instructions:

- Maintain the tank at operating temperature.
- Remove the side shroud cap.
- Lower the discharge ramp located next to the tank and put an appropriate container in place.
- Unscrew the emptying plug and allow the adhesive to flow freely into the container.
- Once completely empty, clean the any remaining adhesive from around the output hole and ramp.



6. Replace the plug.

7. Raise the discharge ramp and replace the side shroud cap.

Warning: Use appropriate protective equipment for high temperatures.



Pump maintenance

Inspecting for leaks

The pump is equipped with a gasket system on the shaft to prevent adhesive from leaking through it. On occasion, some adhesive may leak out, which makes it necessary to retighten the screws or change the gasket.



Warning: Changing the gasket with a hot pump.

Release the shaft coupling from the pump. Retighten or remove the screws that hold the gasket in place. Replace the gaskets and reassemble the parts.

Occasionally, as a result of the system's heating-cooling cycles, it may be necessary to retighten the screws.

Warning: Always wear protective gloves and goggles. Risk of burns.



Motor-gear maintenance

Cleaning the motor fan

Periodically inspect the condition of the motor fan and its vent screen.

If dust has accumulated, blow gently with air to clean it (remove the protective cover, if necessary).

Checking the lubricant

The gear reducers are delivered filled with synthetic grease for lubrication -free of outside contamination- 'for life'. Ambient temperature 0 ÷ 40 °C, with peaks of as low as -20 °C and up to +50 °C.





Use only those lubricants recommended by the manufacturer. The use of other types may cause premature wear or damage to the gear reducer.

Approximately 0.1 kg of lubricating grease fits in the gear reducer model used.

Recommended lubricants

BRAND	TYPE OF OIL
IP	Telesia Compound A
SHELL	Tivela Compound A
MOBIL	Glygoyle Grease 00

Air drier filter maintenance

The filtering elements prior to the air drier device on the melting equipment are equipped with a filter saturation indicator, which indicates the best time to change the filter cartridge:

- *green color*: Low level of cartridge contamination.
- *red color*: The cartridge is contaminated. Replace immediately, otherwise equipment performance cannot be guaranteed.

We recommend installing new cartridges once a year, regardless of the indicator reading (differential pressure).

Follow these steps to change the cartridge:

- close the air valve.
- release the drainage hose from the reservoir, if connected.
- slowly turn the knurled screw clockwise. This will purge the air from the filter.
- push the reservoir towards the head of the filter.
- slowly turn the reservoir clockwise as far as possible (1/8 of a turn) and remove it, pulling down.
- remove the cartridge and replace it with a new one (do not touch the filter screen with your hands).
- mount the reservoir, following these instructions in reverse order.
- pressurize the filter, opening the by-pass valve slowly.



Warning: It is necessary to keep the power connected to the unit in order to keep the air drier system operational. The system may operate even with cold adhesive, in order to keep the internal environment moisture-free.

This page is intentionally left blank.

6. TECHNICAL CHARACTERISTICS

General



Tank capacity	4 liters	8 liters	16 liters
Pump rate			
single pump	6, 24 ó 48 kg/h (*)	6, 24 ó 48 kg/h (*)	6, 24 ó 48 kg/h (*)
double pump (per output)	3.6, 7.2, 14.4 ó 28,8 kg/h (*)	3.6, 7.2, 14.4 ó 28,8 kg/h (*)	3.6, 7.2, 14.4 ó 28,8 kg/h (*)
Melt rate	6,0 kg/h (*)	11,2 kg/h (*)	18 kg/h (*)
Outputs	2, 4 or 6 with a single pump 2 or 4 with two pumps	2, 4 or 6 with a single pump 2 or 4 with two pumps	2, 4 or 6 with a single pump 2 or 4 with two pumps
Temperature range	40 to 200°C (100 to 392°F) (optional) 40 to 230°C (100 to 450°F)	40 to 200°C (100 to 392°F) 40 to 230°C (100 to 450°F)	40 to 200°C (100 a 392°F) 40 to 230°C (100 to 450°F)
Temperature control	RTD ±0.5°C (±1°F) Pt-100 or Ni-120	RTD ±0.5°C (±1°F) Pt-100 or Ni-120	RTD ±0.5°C (±1°F) Pt-100 or Ni-120
Max. working pressure (at 6 bar)	90 bar (1305 psi)	90 bar (1305 psi)	90 bar (1305 psi)
Max. power supply (at 230V)			
with a single pump	6.050 W (2 outputs) 8.450 W (4 outputs) 10.850 W (6 outputs)	7.050 W (2 outputs) 9.450 W (4 outputs) 11.850 W (6 outputs)	7.550 W (2 outputs) 9.950 W (4 outputs) 12.350 W (6 outputs)
with two pumps	6.950 W (2 outputs) 9.350 W (4 outputs)	7.950 W (2 outputs) 10.350 W (4 outputs)	8.450 W (2 outputs) 10.850 W (4 outputs)
External functions	temperatures ok output low level signal (optional) standby input external outlet inhibitor motor start input motor speed control input	temperatures ok output low level signal (optional) standby input external outlet inhibitor motor start input motor speed control input	temperatures ok output low level signal (optional) standby input external outlet inhibitor motor start input motor speed control input
Electrical requirements	230V 1~ 50/60 Hz + N + PE 400V 3~ 50/60 Hz + N + PE	230V 1~ 50/60 Hz + N + PE 400V 3~ 50/60 Hz + N + PE	230V 1~ 50/60 Hz + N + PE 400V 3~ 50/60 Hz + N + PE
Workplace temperature	0 to 40°C	0 to 40°C	0 to 40°C
Dimensions (LxWxH)			
with a single pump	650x308x660	726x308x660	809x308x760
with two pumps	650x308x860	726x308x860	809x308x960

(*) Under standard conditions

Dimensions



micron4



micron8



micron16

Accessories

Pneumatic by-pass valve pressure control system

The equipment's by-pass valve provides an important safety feature, as it limits the maximum pressure in the system, especially during continuous pumping periods with closed applicator guns.

This valve may be manually adjusted by a threaded spindle. It is possible to add a pneumatic adjustment system, which uses a pressure regulator and a pressure gauge display with a 1 to 15 ratio to the hydraulic pressure.

Level control system

To control the hot-melt level from the control card display screen or from the main machine, using the NO (normally open) contact, with no voltage.

Air drying system for PUR adhesives

Polyurethane-based reactive adhesives, known as P.U.R. (reactive polyurethanes), require a completely dry environment before they can be applied, since when they come in contact with atmospheric humidity, they reticulate, hardening quickly.

The 'micron gear' melting equipment ensures a dry environment thanks to the addition of an air-drying system to these models, which provides a level of dehumidification above 99.98%. This guarantees that the adhesive is preserved without premature reticulations inside the applicator unit.

Automatic tank filling system

'meler' pellet loaders ensure a continuous level of adhesive inside the tanks of the melting units, eliminating the need for manual loading by the user.

Each time the tank sensor detects a low level of adhesive, it sends a signal to the suction system, which transfers a load of pellets to the melting tank from the adhesive container (or directly from the bag it comes in).



This page is intentionally left blank.

7. ELECTRICAL DRAWINGS

Components list version Pt-100

Version with a single pump installed

-1A1	Power card (2 or 6 outputs)
-1B3	Level sensor
-1B4	240°C safety thermostat
-1K3	2-contact 220V AC relay motor start enabled
-1R4	Tank resistance 2000W 230V (4)
-1R4.1	Tank resistance 3000W 230V (8)
-1R4.2	Tank resistance 3500W 230V (16)
-1R5	Distributor resistance 300W (single or double pump)
-1R5.1	Distributor resistance 300W (single or double pump)
-1R6	Distributor resistance 300W (single or double pump)
-1R6.1	Distributor resistance 300W (double pump)
-1S2	ON-OFF switch
-2A3	Sensor card
-2B2	Pt-100 tank temperature sensor
-2B2.1	Pt-100 distributor temperature sensor
-2CN1	8-pole channel 1 connector
-2CN3.2	8-pole channel 2 connector
-2CN4.2	8-pole channel 3 connector
-2CN5.3	8-pole channel 4 connector
-2CN6.1	8-pole channel 5 connector
-2CN7	8-pole channel 6 connector
-3A1	Control card
-3K7	2-contact 24V DC relay for control circuit power
-4A5	Motor inverter 230V AC 0.35kW
-4K2	2-contact 24V DC relay for fan start
-4K2.1	2-contact 24V DC relay for set point reference
-4M7	0.25kW geared motor with booster fan
-4P3	Motor revolutions display
-4R3	Maximum speed motor 'RATIO' potentiometer
-4R4	Motor 'R.P.M.' speed regulation potentiometer
-4S2	MANUAL/OFF/AUTO switch
-4S2.1	INT/EXT switch
-F01	Tank fuse 16A 500V gG
-F02	Distributor fuse 6A 500V gG
-F03	Low level signal fuse 2A 250V F
-F04	Channel 1 fuse (hose-gun) 6A 250V F
-F05	Channel 2 fuse (hose-gun) 6A 250V F
-F06	Channel 3 fuse (hose-gun) 6A 250V F
-F07	Channel 4 fuse (hose-gun) 6A 250V F
-F08	Channel 5 fuse (hose-gun) 6A 250V F
-F09	Channel 6 fuse (hose-gun) 6A 250V F
-F10	DC Power supply fuse 0.5A 250V T
-X1	Motor start input terminals
-X2	Motor speed set point terminals (0-10V DC)
-X3	Ceramic power block connection to distributor
-X4	Ceramic power block connection to level detector

-X5/X6 Control circuit power input terminals

Optionally:

- 3G6 DC power supply 220V AC/24V DC 15W
- 3T7 Air drying system timer
- 3CN7 Air drying system solenoid valve connector

Version with two pumps installed

- 1A1 Power card (6 outputs)
- 1B3 Level sensor
- 1B4 240°C safety thermostat
- 1K3 2-contact 220V AC relay motor start enabled
- 1R4 Tank resistance 2000W 230V (4)
- 1R4.1 Tank resistance 3000W 230V (8)
- 1R4.2 Tank resistance 3500W 230V (16)
- 1R5 Distributor1 resistance 300W (single or double pump)
- 1R5.1 Distributor1 resistance 300W (single or double pump)
- 1R6 Distributor1 resistance 300W (single or double pump)
- 1R6.1 Distributor1 resistance 300W (double pump)
- 1R7 Distributor2 resistance 300W (single or double pump)
- 1R7.1 Distributor2 resistance 300W (single or double pump)
- 1R8 Distributor2 resistance 300W (single or double pump)
- 1R8.1 Distributor2 resistance 300W (double pump)
- 1S2 ON-OFF switch
- 2A3 Sensor card
- 2B2 Pt-100 tank temperature sensor
- 2B2.1 Pt-100 tank temperature sensor
- 2B2.2 Pt-100 distributor1 temperature sensor
- 2B3 Pt-100 distributor2 temperature sensor
- 2CN4.2 8-pole channel 3 connector
- 2CN5.3 8-pole channel 4 connector
- 2CN6.1 8-pole channel 5 connector
- 2CN7 8-pole channel 6 connector
- 3A1 Control card
- 3K7 2-contact 24V DC relay for control circuit power
- 4A5 Motor1 inverter 230V AC 0.35kW
- 4K2 2-contact 24V DC relay for fan1 start
- 4K2.1 2-contact 24V DC relay for set point reference1
- 4M7 0.25kW geared motor1 with booster fan
- 4P3 Motor1 revolutions display
- 4R3 Maximum speed motor1 'RATIO' potentiometer
- 4R4 Motor1 'R.P.M.' speed regulation potentiometer
- 4S2 MANUAL/OFF/AUTO switch motor1
- 4S2.1 INT/EXT switch motor1
- 5A5 Motor2 inverter 230V AC 0.35kW
- 5K2 2-contact 24V DC relay for fan2 start
- 5K2.1 2-contact 24V DC relay for set point reference2
- 5M7 0.25kW geared motor2 with booster fan

-5P3	Motor2 revolutions display
-5R3	Maximum speed motor2 'RATIO' potentiometer
-5R4	Motor2 'R.P.M.' speed regulation potentiometer
-5S2	MANUAL/OFF/AUTO switch motor2
-5S2.1	INT/EXT switch motor2
-F01	Tank fuse 16A 500V gG
-F02	Distributor fuse 6A 500V gG
-F03	Low level signal fuse 2A 250V F
-F04	Distributor1 fuse 6A 250V F
-F05	Distributor2 fuse 6A 250V F
-F06	Channel 1 fuse (hose-gun) 6A 250V F
-F07	Channel 2 fuse (hose-gun) 6A 250V F
-F08	Channel 3 fuse (hose-gun) 6A 250V F
-F09	Channel 4 fuse (hose-gun) 6A 250V F
-F10	DC Power supply fuse 0.5A 250V T
-X1(1)	Motor start input terminals
-X2(1)	Motor speed set point terminals (0-10V DC)
-X1(2)	Motor start input terminals
-X2(2)	Motor speed set point terminals (0-10V DC)
-X3	Ceramic power block connection to distributor1
-X4	Ceramic power block connection to level detector
-X5/X6	Control circuit power input terminals
-X7	Ceramic power block connection to distributor2

Optionally:

-3G6	DC power supply 220V AC/24V DC 15W
-3T7	Air drying system timer
-3CN7	Air drying system solenoid valve connector

Components list version Ni-120

Version with a single pump installed

-1A1	Power card (2 or 6 outputs)
-1B3	Level sensor
-1B4	240°C safety thermostat
-1K3	2-contact 220V AC relay motor start enabled
-1R4	Tank resistance 2000W 230V (4)
-1R4.1	Tank resistance 3000W 230V (8)
-1R4.2	Tank resistance 3500W 230V (16)
-1R5	Distributor resistance 300W (single or double pump)
-1R5.1	Distributor resistance 300W (single or double pump)
-1R6	Distributor resistance 300W (single or double pump)
-1R6.1	Distributor resistance 300W (double pump)
-1S2	ON-OFF switch
-2A3	Sensor card
-2B2	Ni-120 tank temperature sensor
-2B2.1	Ni-120 distributor temperature sensor
-2CN1	12-pole channel 1 connector
-2CN3.2	12-pole channel 2 connector

-2CN4.2	12-pole channel 3 connector
-2CN5.3	12-pole channel 4 connector
-2CN6.1	12-pole channel 5 connector
-2CN7	12-pole channel 6 connector
-3A1	Control card
-3K7	2-contact 24V DC relay for control circuit power
-4A5	Motor inverter 230V AC 0.35kW
-4K2	2-contact 24V DC relay for fan start
-4K2.1	2-contact 24V DC relay for set point reference
-4M7	0.25kW geared motor with booster fan
-4P3	Motor revolutions display
-4R3	Maximum speed motor 'RATIO' potentiometer
-4R4	Motor 'R.P.M.' speed regulation potentiometer
-4S2	MANUAL/OFF/AUTO switch
-4S2.1	INT/EXT switch
-F01	Tank fuse 16A 500V gG
-F02	Distributor fuse 6A 500V gG
-F03	Low level signal fuse 2A 250V F
-F04	Channel 1 fuse (hose-gun) 6A 250V F
-F05	Channel 2 fuse (hose-gun) 6A 250V F
-F06	Channel 3 fuse (hose-gun) 6A 250V F
-F07	Channel 4 fuse (hose-gun) 6A 250V F
-F08	Channel 5 fuse (hose-gun) 6A 250V F
-F09	Channel 6 fuse (hose-gun) 6A 250V F
-F10	DC Power supply fuse 0.5A 250V T
-X1	Motor start input terminals
-X2	Motor speed set point terminals (0-10V DC)
-X3	Ceramic power block connection to distributor
-X4	Ceramic power block connection to level detector
-X5/X6	Control circuit power input terminals

Optionally:

-3G6	DC power supply 220V AC/24V DC 15W
-3T7	Air drying system timer
-3CN7	Air drying system solenoid valve connector

Version with two pumps installed

-1A1	Power card (6 outputs)
-1B3	Level sensor
-1B4	240°C safety thermostat
-1K3	2-contact 220V AC relay motor start enabled
-1R4	Tank resistance 2000W 230V (4)
-1R4.1	Tank resistance 3000W 230V (8)
-1R4.2	Tank resistance 3500W 230V (16)
-1R5	Distributor1 resistance 300W (single or double pump)
-1R5.1	Distributor1 resistance 300W (single or double pump)
-1R6	Distributor1 resistance 300W (single or double pump)
-1R6.1	Distributor1 resistance 300W (double pump)
-1R7	Distributor2 resistance 300W (single or double pump)

-1R7.1	Distributor2 resistance 300W (single or double pump)
-1R8	Distributor2 resistance 300W (single or double pump)
-1R8.1	Distributor2 resistance 300W (double pump)
-1S2	ON-OFF switch
-2A3	Sensor card
-2B2	Ni-120 tank temperature sensor
-2B2.1	Ni-120 tank temperature sensor
-2B2.2	Ni-120 distributor1 temperature sensor
-2B3	Ni-120 distributor2 temperature sensor
-2CN4.2	12-pole channel 3 connector
-2CN5.3	12-pole channel 4 connector
-2CN6.1	12-pole channel 5 connector
-2CN7	12-pole channel 6 connector
-3A1	Control card
-3K7	2-contact 24V DC relay for control circuit power
-4A5	Motor1 inverter 230V AC 0.35kW
-4K2	2-contact 24V DC relay for fan1 start
-4K2.1	2-contact 24V DC relay for set point reference1
-4M7	0.25kW geared motor1 with booster fan
-4P3	Motor1 revolutions display
-4R3	Maximum speed motor1 'RATIO' potentiometer
-4R4	Motor1 'R.P.M.' speed regulation potentiometer
-4S2	MANUAL/OFF/AUTO switch motor1
-4S2.1	INT/EXT switch motor1
-5A5	Motor2 inverter 230V AC 0.35kW
-5K2	2-contact 24V DC relay for fan2 start
-5K2.1	2-contact 24V DC relay for set point reference2
-5M7	0.25kW geared motor2 with booster fan
-5P3	Motor2 revolutions display
-5R3	Maximum speed motor2 'RATIO' potentiometer
-5R4	Motor2 'R.P.M.' speed regulation potentiometer
-5S2	MANUAL/OFF/AUTO switch motor2
-5S2.1	INT/EXT switch motor2
-F01	Tank fuse 16A 500V gG
-F02	Distributor fuse 6A 500V gG
-F03	Low level signal fuse 2A 250V F
-F04	Distributor1 fuse 6A 250V F
-F05	Distributor2 fuse 6A 250V F
-F06	Channel 1 fuse (hose-gun) 6A 250V F
-F07	Channel 2 fuse (hose-gun) 6A 250V F
-F08	Channel 3 fuse (hose-gun) 6A 250V F
-F09	Channel 4 fuse (hose-gun) 6A 250V F
-F10	DC Power supply fuse 0.5A 250V T
-X1(1)	Motor start input terminals
-X2(1)	Motor speed set point terminals (0-10V DC)
-X1(2)	Motor start input terminals
-X2(2)	Motor speed set point terminals (0-10V DC)
-X3	Ceramic power block connection to distributor1
-X4	Ceramic power block connection to level detector
-X5/X6	Control circuit power input terminals

-X7 Ceramic power block connection to distributor2

Optionally:

- 3G6 DC power supply 220V AC/24V DC 15W
- 3T7 Air drying system timer
- 3CN7 Air drying system solenoid valve connector

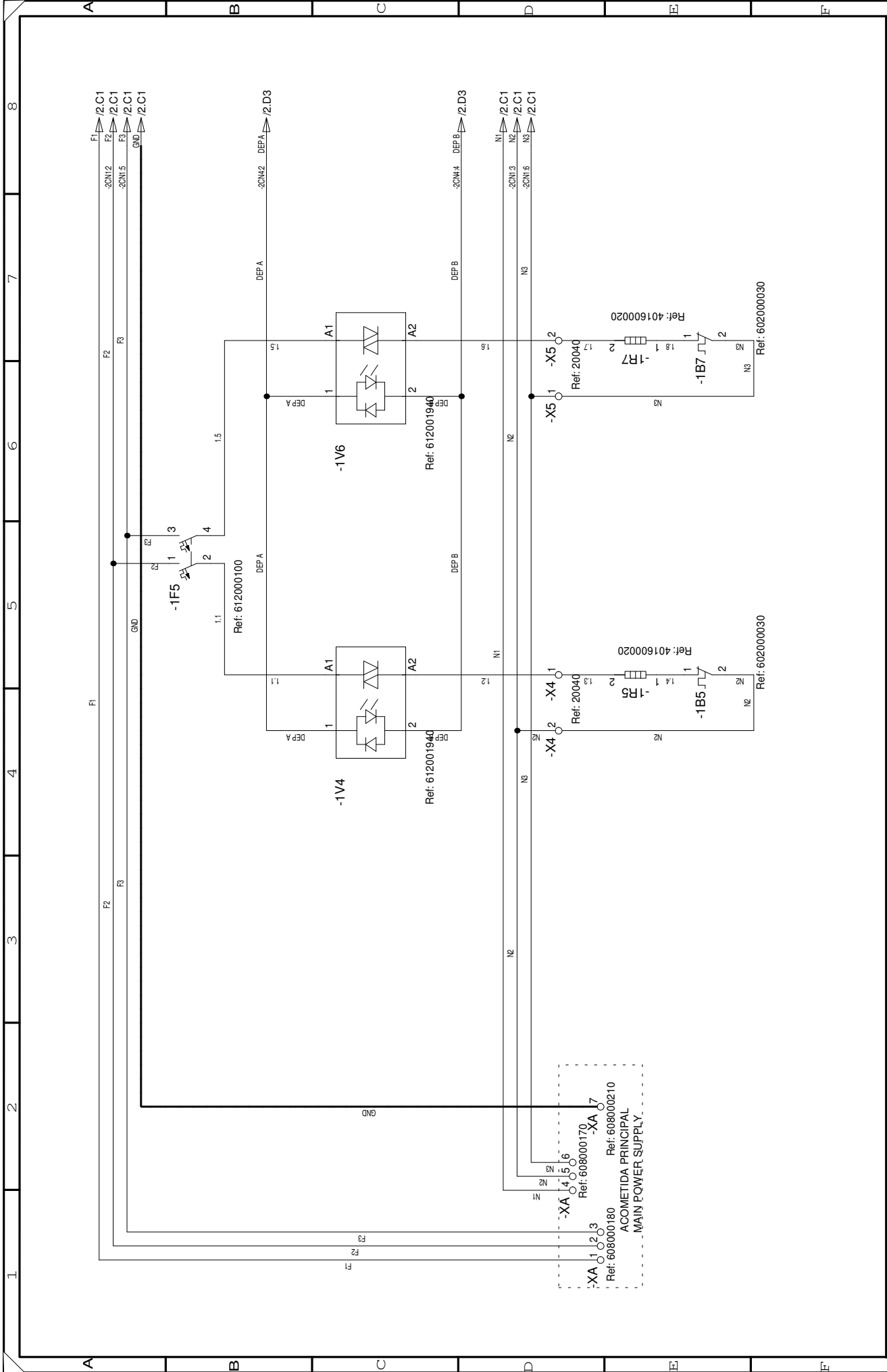

FECHA / DATE	NOMBRE / NAME	EQUIPO / EQUIPMENT	DISP. : SIT. :
22/01/2009	JESUS ZAPATA	MICRON 32 GEAR	REFERENCIA / REFERENCE
29/01/2009	JESUSZ	1 MOTOR PT100	101300430E
			HOJA / SHEET 1 7
meler		DENOMINACIÓN / NAME CABLEADO DEL CIRCUITO DE POTENCIA WIRING OF THE POWER CIRCUIT	

REF: 608000170 -XA 7
 REF: 608000180 -XA 7
 REF: 608000210 -XA 7
 ACOMETIDA PRINCIPAL
 MAIN POWER SUPPLY

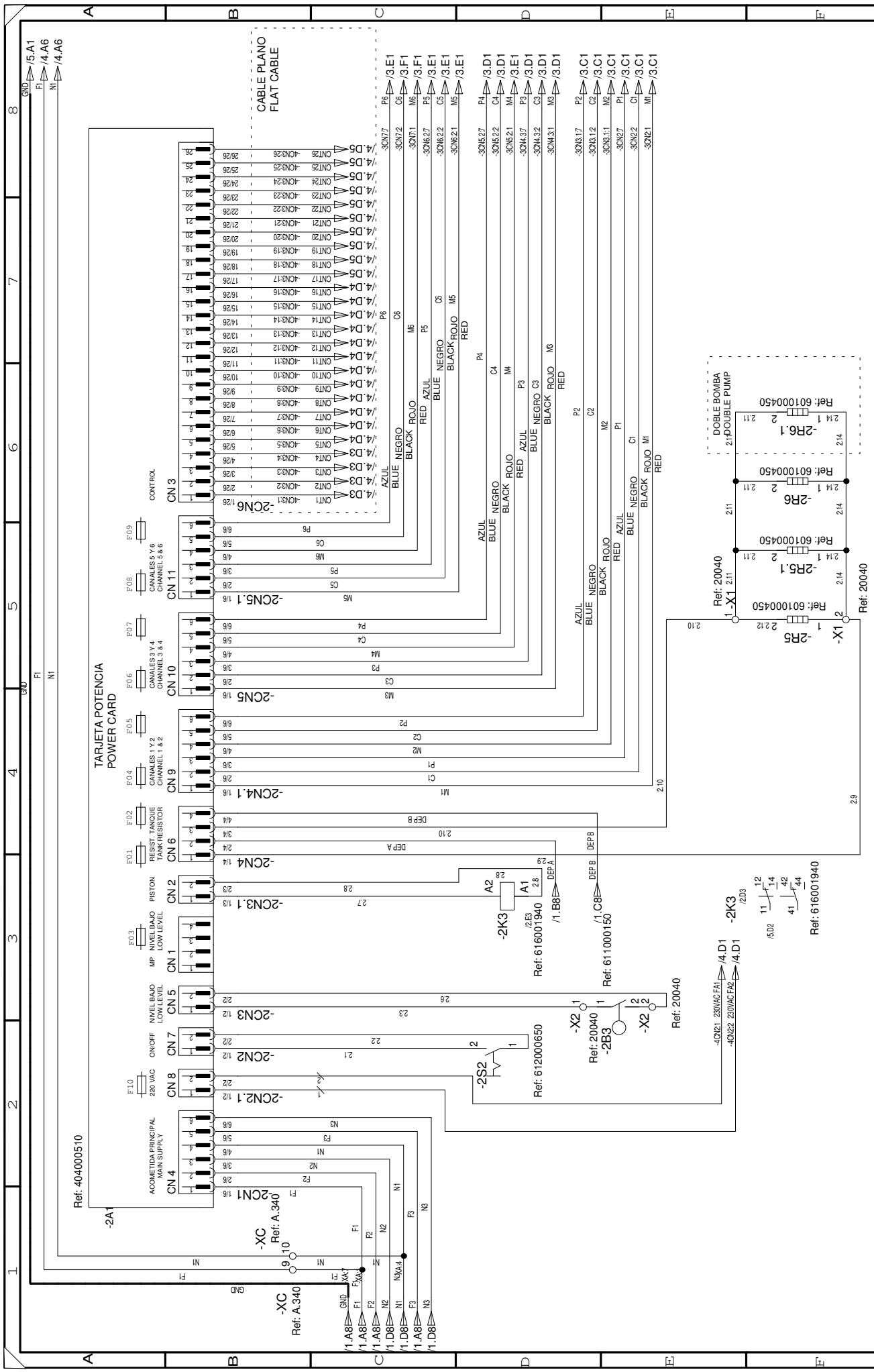

DISP.: REPUBLICA Y REFERENCIA 101300430E_		S.I.C.C.:	
EQUIPO/EQUIPMENT: MICRON 32 GEAR 1 MOTOR PT100		HOJA/SHEET: 2 / 7	
DEMINACIÓN/NAME:			
CABLEADO DEL CIRCUITO DE POTENCIA WIRING OF THE POWER CIRCUIT			
FECHA/DATE: 14/01/2008 29/01/2009		NOMBRE/NAME: JESUS ZAPATA JESUSZ	
DIBUJADO/DRAWN:		MODIFICADO/PROF.FIED:	
CLIENTE/CUSTOMER:			

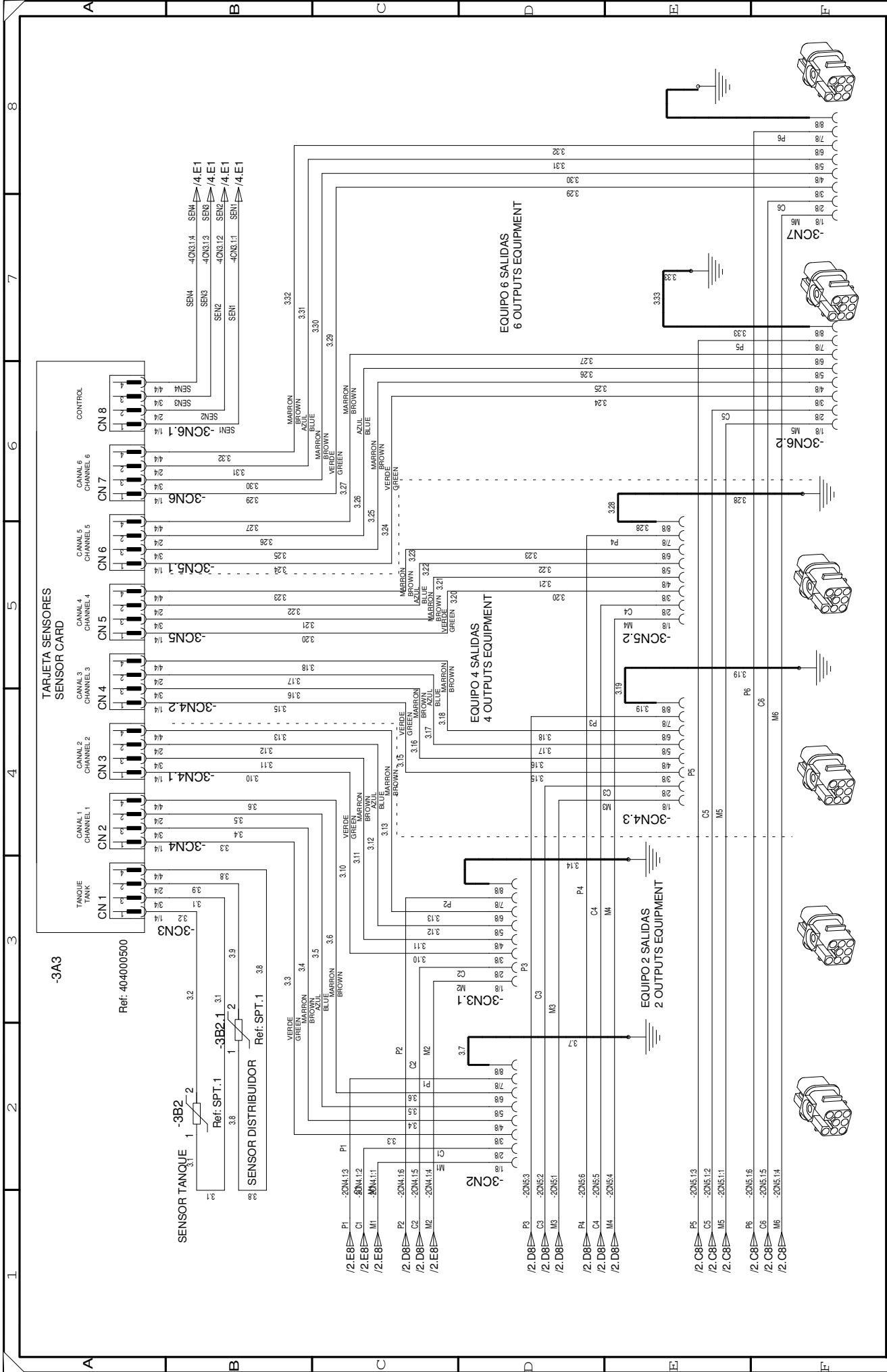

FECHA / DATE	21/01/2008	NOMBRE / NAME	JESUS ZAPATA
DISEÑADO / DRAWN	29/01/2009		JESUSZ
MODIFICADO / MODIFIED			
CLIENTE / CUSTOMER			
DENOMINACIÓN / NAME	CABLEADO DEL CIRCUITO DE SENSORES WIRING OF THE SENSOR CIRCUIT		
EQUIPO / EQUIPMENT	MICRON 32 GEAR 1 MOTOR PT100		
DISP. : REFERENCIA / REFERENCE	101300430E_		
HOJA / SHEET	3		7



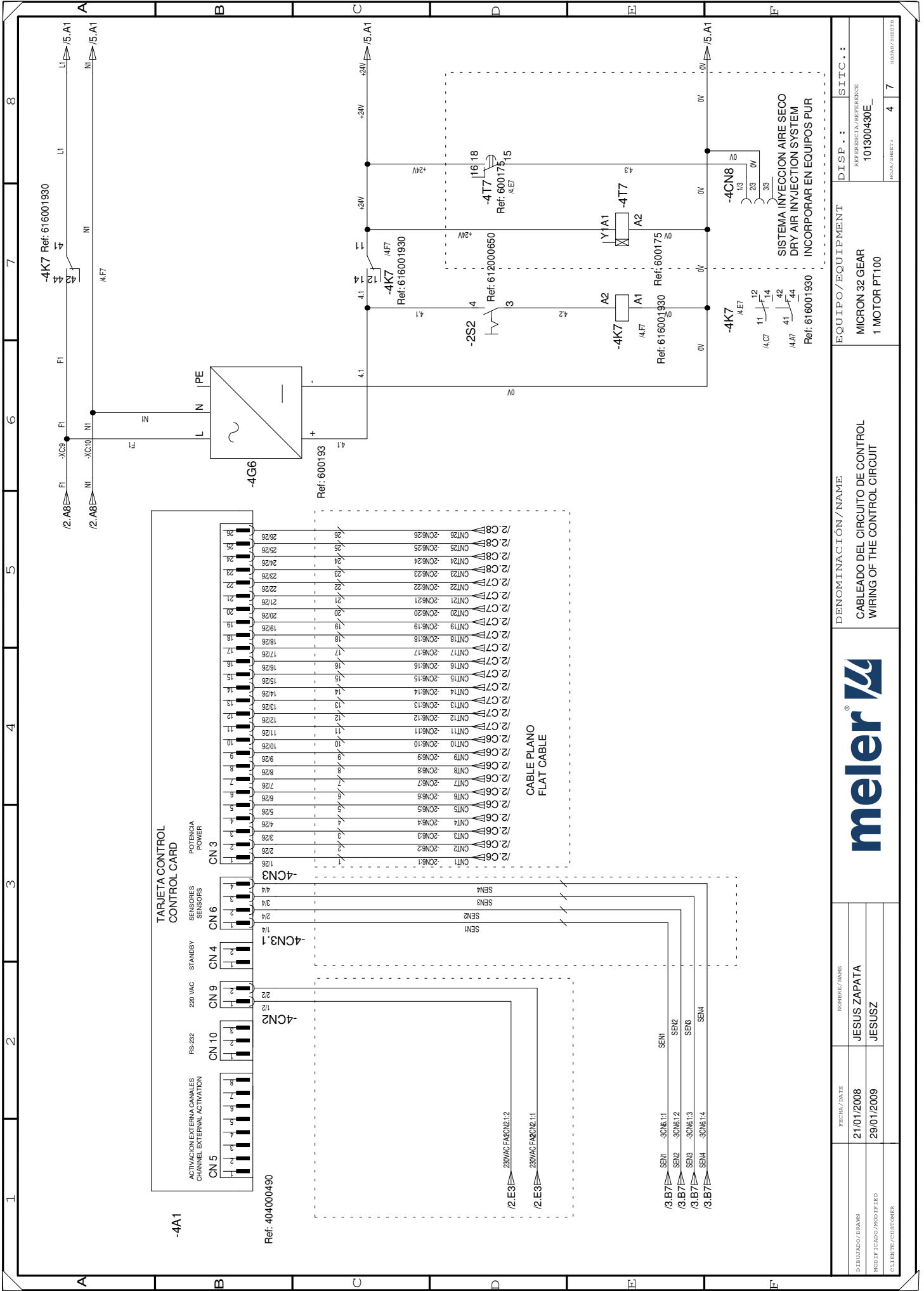

DENOMINACIÓN / NAME
 CABLEADO DEL CIRCUITO DE CONTROL
 WIRING OF THE CONTROL CIRCUIT

EQUIPO / EQUIPMENT
 MICRON 32 GEAR
 1 MOTOR PT100

DISP.: SIIC.:
 REFERENCIA / REFERENCE
 101300430E_
 HOJA / SHEET: 4 7
 HOJAS / SHEETS

FECHA / DATE	21/01/2008
NOMBRE / NAME	JESUS ZAPATA
MODIFICADO / MODIFIED	29/01/2009
CLIENTE / CUSTOMER	JESUSZ

CABLE PLANO
FLAT CABLE

1/2	CNT1	20N6:1
2	CNT2	20N6:2
3	CNT3	20N6:3
4	CNT4	20N6:4
5	CNT5	20N6:5
6	CNT6	20N6:6
7	CNT7	20N6:7
8	CNT8	20N6:8
9	CNT9	20N6:9
10	CNT10	20N6:10
11	CNT11	20N6:11
12	CNT12	20N6:12
13	CNT13	20N6:13
14	CNT14	20N6:14
15	CNT15	20N6:15
16	CNT16	20N6:16
17	CNT17	20N6:17
18	CNT18	20N6:18
19	CNT19	20N6:19
20	CNT20	20N6:20
21	CNT21	20N6:21
22	CNT22	20N6:22
23	CNT23	20N6:23
24	CNT24	20N6:24
25	CNT25	20N6:25
26	CNT26	20N6:26
27	CNT27	20N6:27
28	CNT28	20N6:28

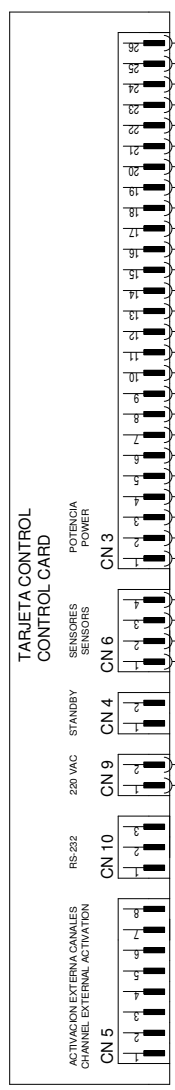

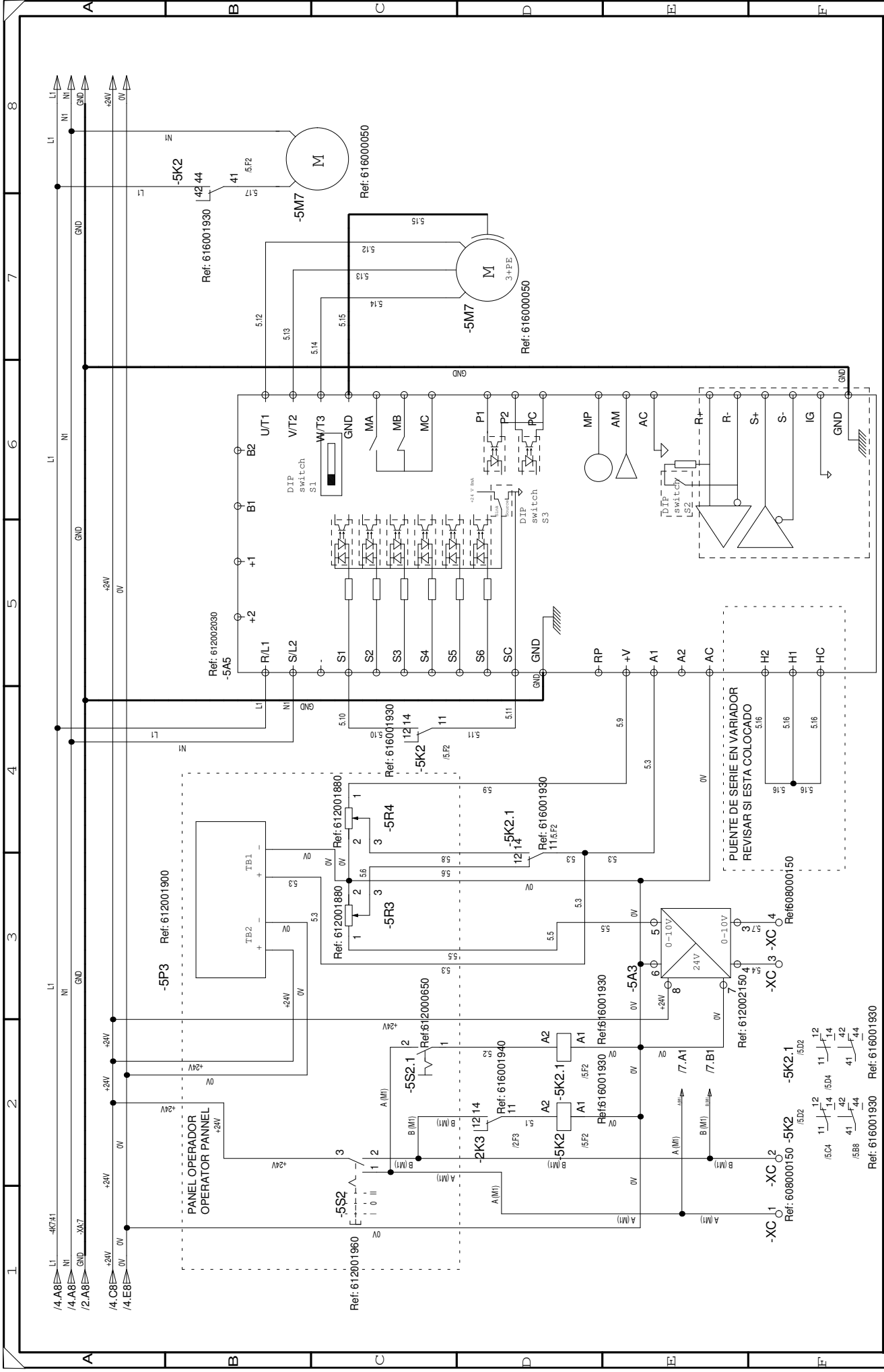

FECHA / DATE		NOMBRE / NAME	
23/01/2008		JESUS ZAPATA	
29/01/2009		JESUSZ	
DISEÑADO/DRAWN		EQUIPO/EQUIPMENT	
MODIFICADO/ADJUSTED		MICRON 32 GEAR	
CLIENTE/CUSTOMER		1 MOTOR PT100	
DISP.: 101300430E		S.I.C.:	
MOD/A/PIBET:		5	
		7	



DENOMINACIÓN / NAME
 CABLEADO DEL CIRCUITO DE MOTOR M1
 WIRING OF THE MOTOR CIRCUIT M1

1		2		3		4		5		6		7		8	
A		B		C		D		E		F		A		B	
DIBUJANDO/DRAWN		FECHA / DATE		NOMBRE / NAME				DENOMINACIÓN / NAME		EQUIPO / EQUIPMENT		DISP. :		SIIC. :	
MODIFICADO/MODIFIED		29/01/2008		JESUS ZAPATA								RESERVA		MICRON 32 GEAR	
CLIENTE / CUSTOMER		29/01/2009		JESUSZ				RESERVE		1 MOTOR PT100		HOJA / SHEET :		HOJA / SHEET :	

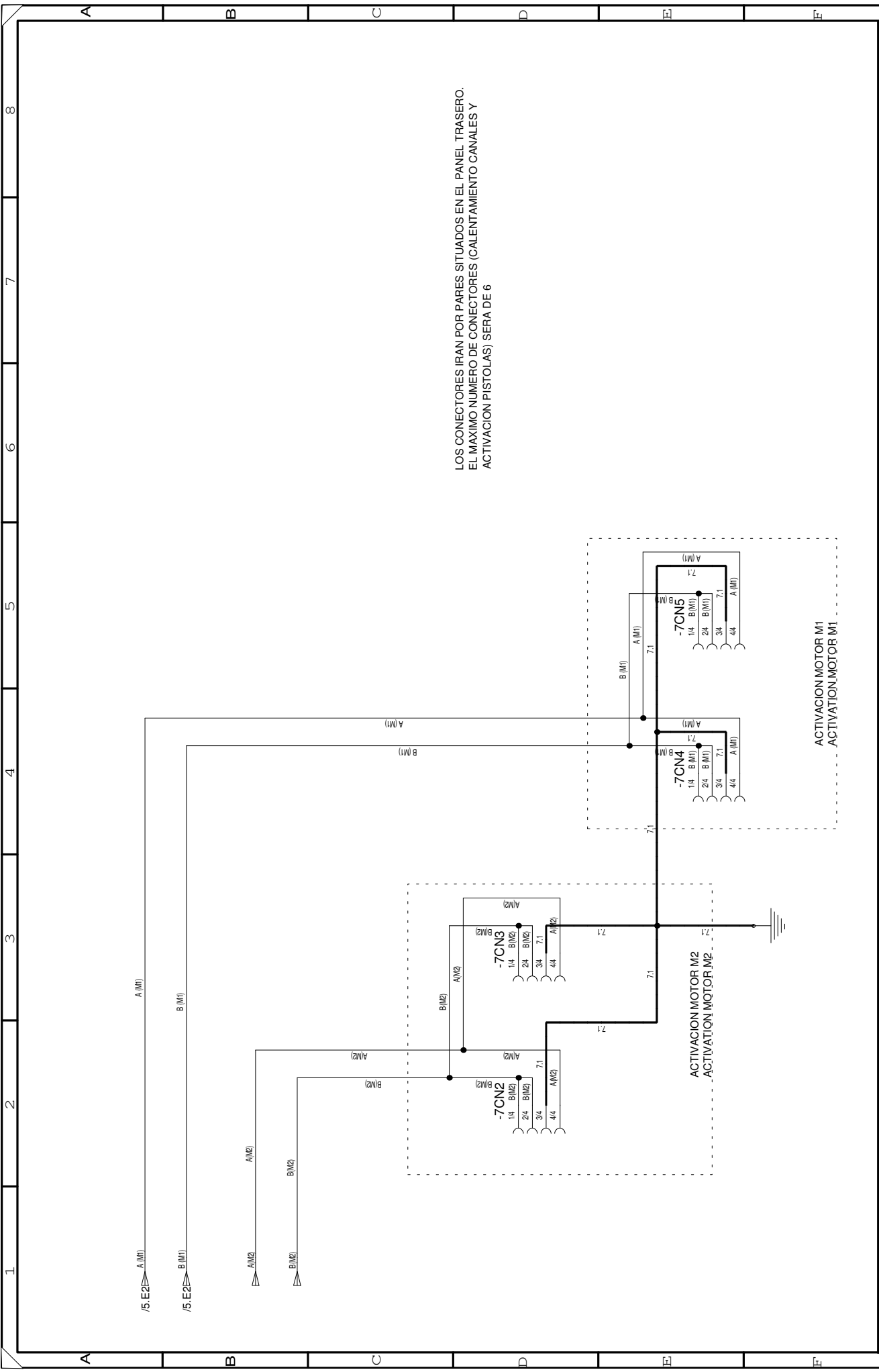

LOS CONECTORES IRAN POR PARES SITUADOS EN EL PANEL TRASERO.
 EL MAXIMO NUMERO DE CONECTORES (CALENTAMIENTO CANALES Y
 ACTIVACION PISTOLAS) SERA DE 6

FECHA / DATE		NOMBRE / NAME	
29/01/2008		JESUS ZAPATA	
29/01/2009		JESUSZ	
DISEÑADO / DRAWN		EQUIPO / EQUIPMENT	
MODIFICADO / MODIFIED		MICRON 32 GEAR	
CLIENTE / CUSTOMER		1 MOTOR PT100	
DISP. :		S.I.C. :	
101300430E		101300430E	
HOJA / SHEET :		7	
7		7	



DENOMINACIÓN / NAME:
 CONEXIONES ACTIVACION POR PISTOLA
 CONNECTIONS ACTIVATION BY GUN

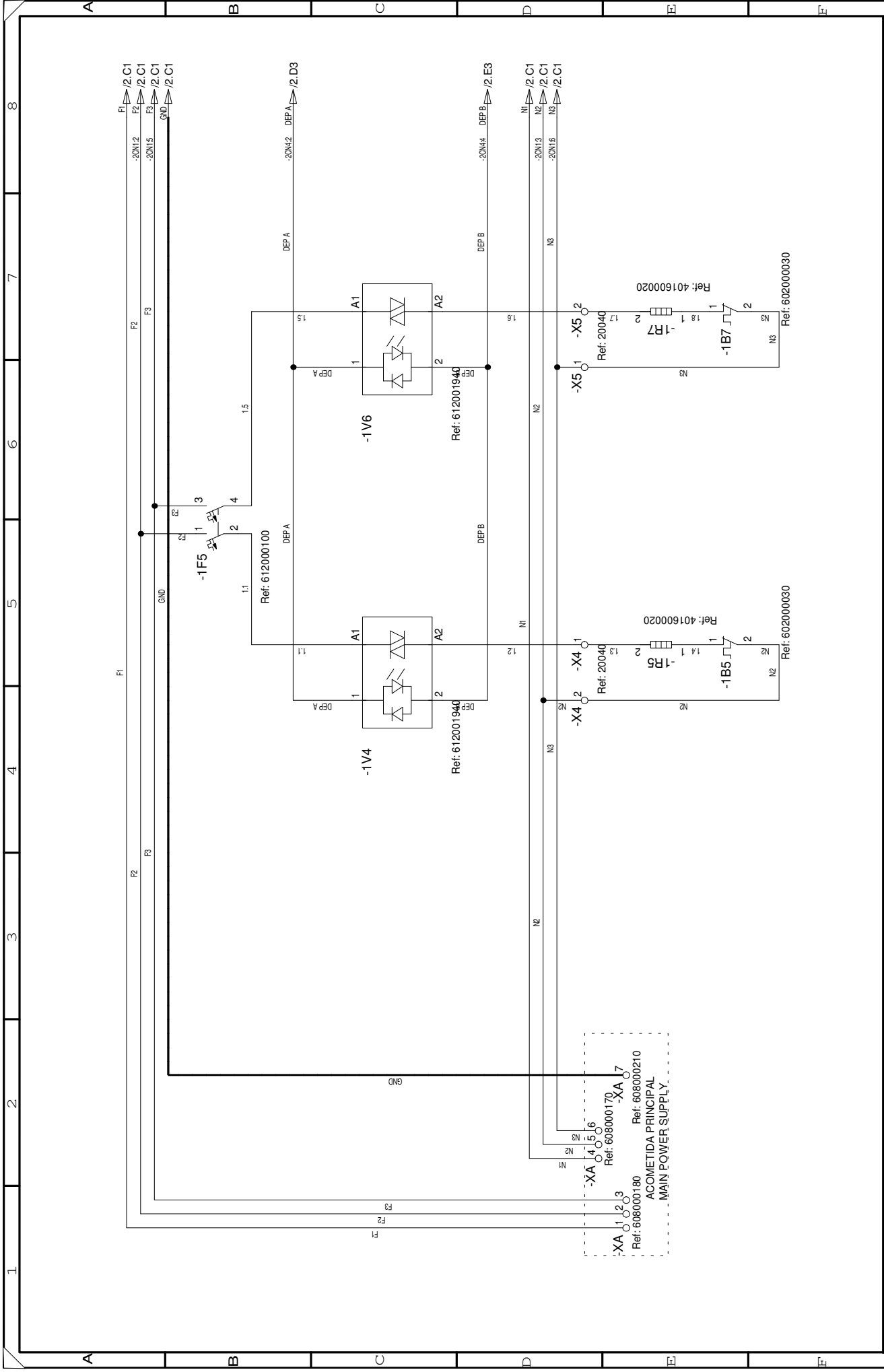

FECHA / DATE	22/01/2009	NOMBRE / NAME	JESUS ZAPATA
DISEÑADOR / DRAWN	29/01/2009		JESUSZ
MODIFICADO / MODIFIED			
CLIENTE / CUSTOMER			
DENOMINACIÓN / NAME		EQUIPO / EQUIPMENT	
CABLEADO DEL CIRCUITO DE POTENCIA		MICRON 32 GEAR	
WIRING OF THE POWER CIRCUIT		2 MOTORES PT100	
DISP. :	101300300E	REFERENCIA / REFERENCE	
HOJA / SHEET :	1	SIT. :	7

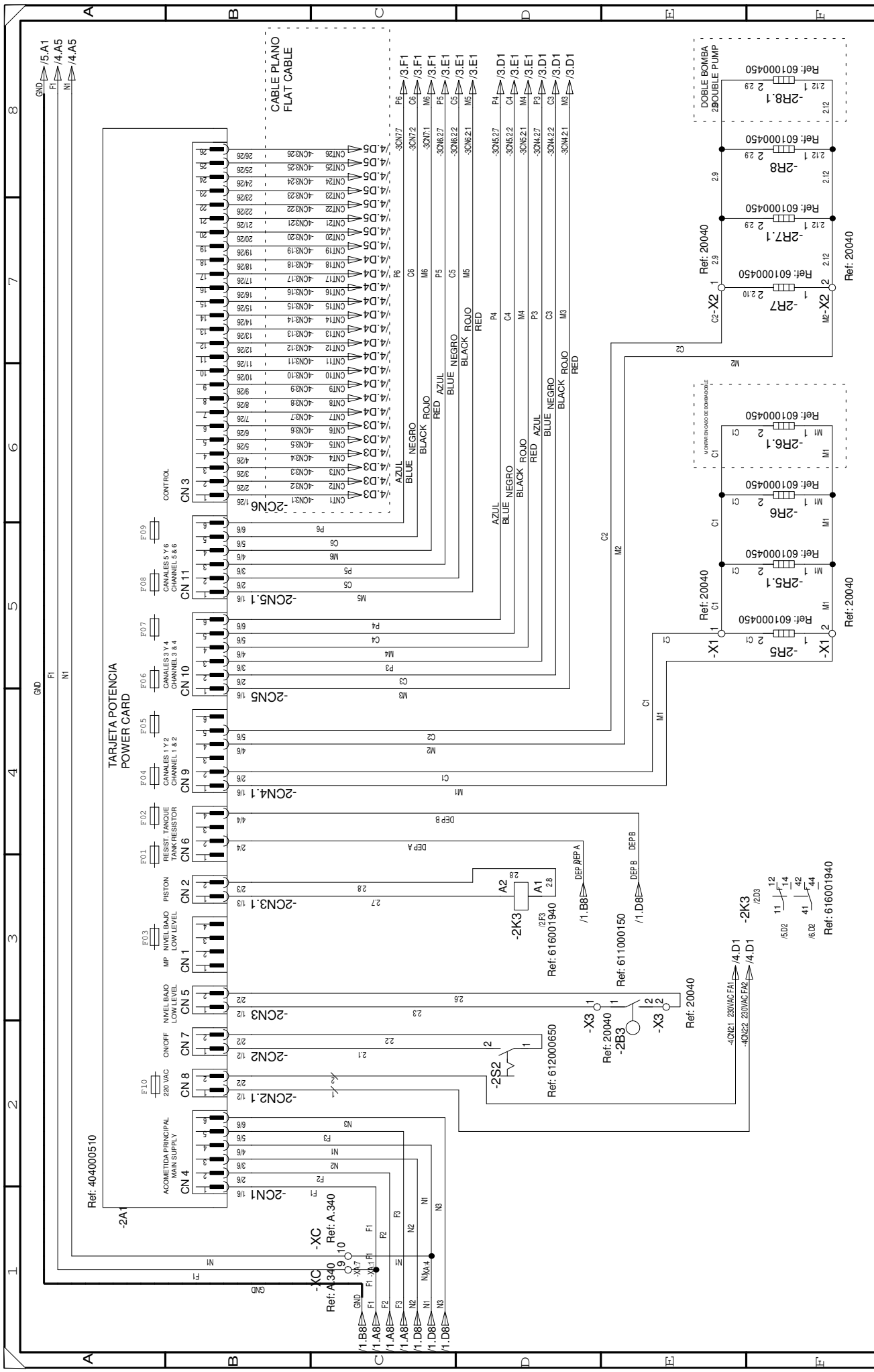

TARJETA POTENCIA POWER CARD		EQUIPO/EQUIPMENT MICRON 32 GEAR 2 MOTORES PT100	
DISP.: SIIC.		REPERTECIA Y REFERENCIA 101300300E	
FECHA / DATE 14/01/2008 29/01/2009		HOJA / SHEET 2 / 7	
DISEÑADO/DRAWN MODIFICADO/PROF. FIED CLIENTE/CUSTOMER		DEMINACIÓN / NAME CABLEADO DEL CIRCUITO DE POTENCIA WIRING OF THE POWER CIRCUIT	
NOMBRE / NAME JESUS ZAPATA JESUSZ			

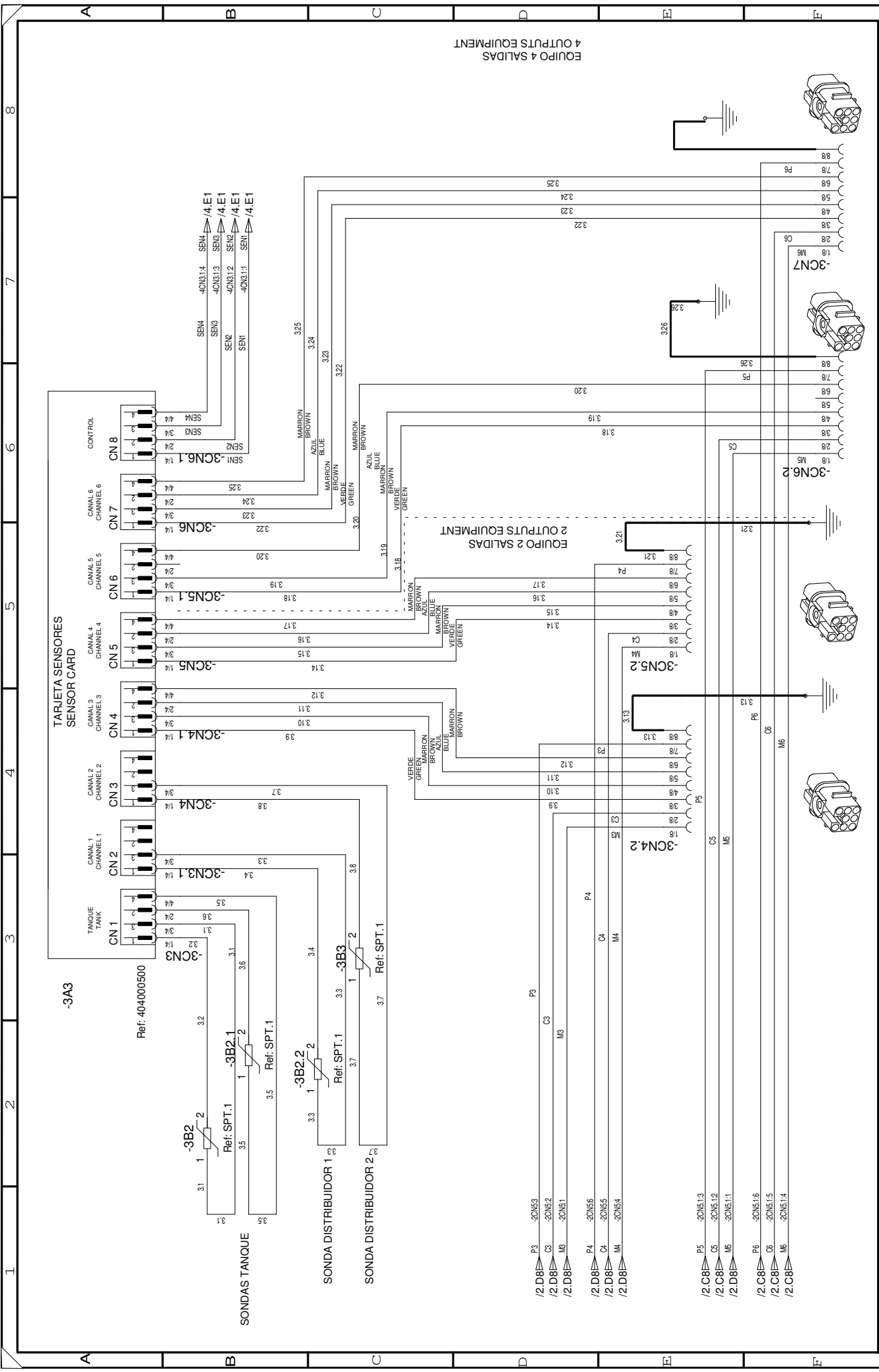

FECHA / DATE		NOMBRE / NAME	
21/01/2008		JESUS ZAPATA	
29/01/2009		JESUSZ	
DISEÑADO/DRAWN		MODIFICADO/MODIFIED	
CLIENTE/CUSTOMER		MODIFY/REBTE	
meler			
DENOMINACIÓN / NAME		EQUIPO / EQUIPMENT	
CABLEADO DEL CIRCUITO DE SENSORES		MICRON 32 GEAR	
WIRING OF THE SENSOR CIRCUIT		2 MOTORES PT100	
DISP. :	SIT. :		
101300300E	101300300E		
HOJA / SHEET :	3	7	

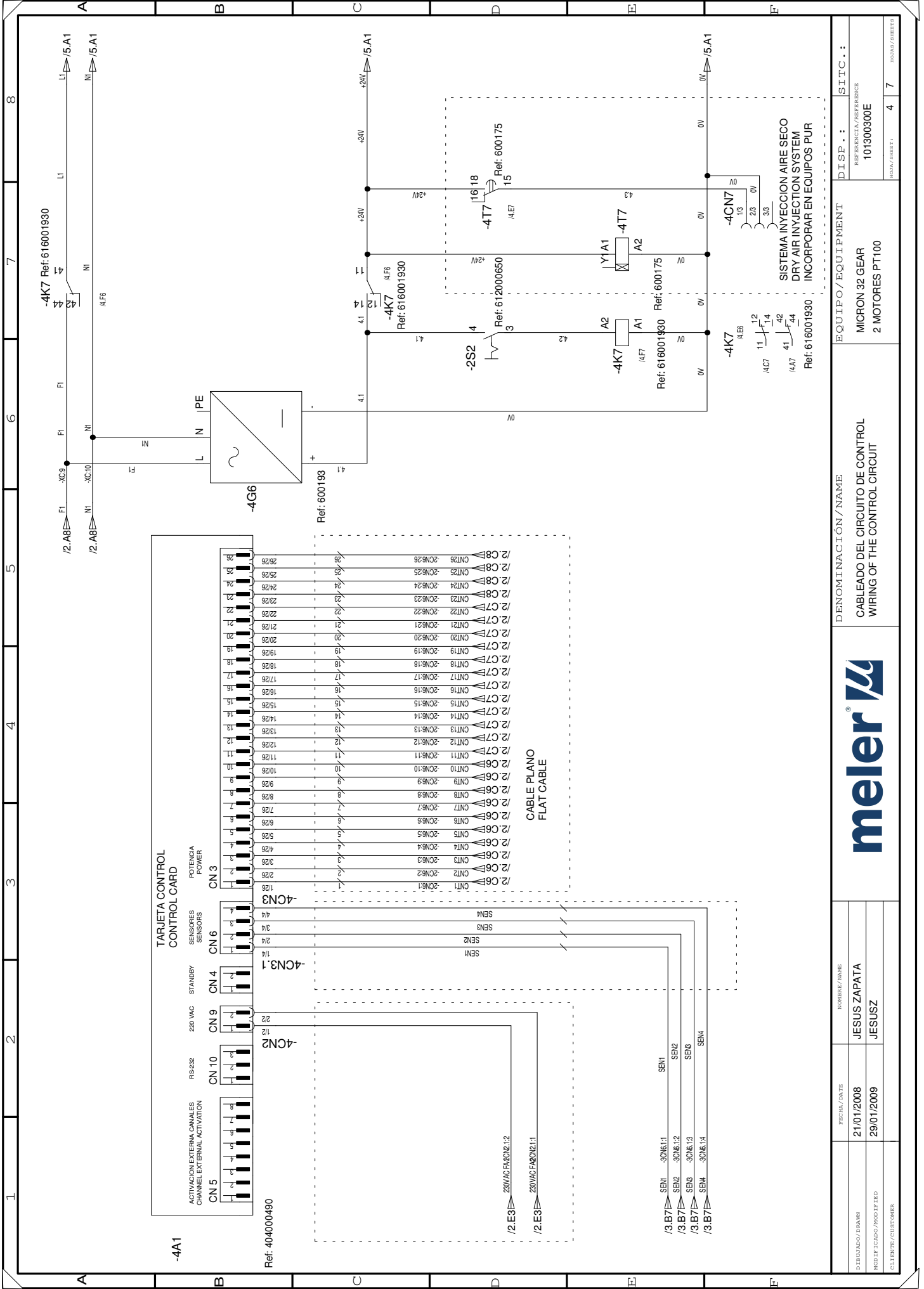

DEMINACIÓN/NAME
CABLEADO DEL CIRCUITO DE CONTROL
WIRING OF THE CONTROL CIRCUIT

EQUIPO/EQUIPMENT
MICRON 32 GEAR
2 MOTORES PT100

DISP.: SIIC.:
 REPERTEJO/REFERENCE:
 101300300E
 HOJA/SHEET: 4 7
 HOJAS/SHEETS

DIBUJADO/DRAWN	FECHA/DATE	NOMBRE/NAME
MODIFICADO/PROCESSED	21/01/2008	JESUS ZAPATA
CLIENTE/CUSTOMER	29/01/2009	JESUSZ

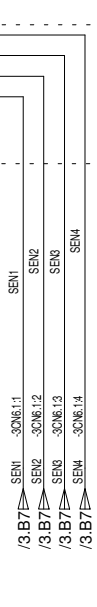
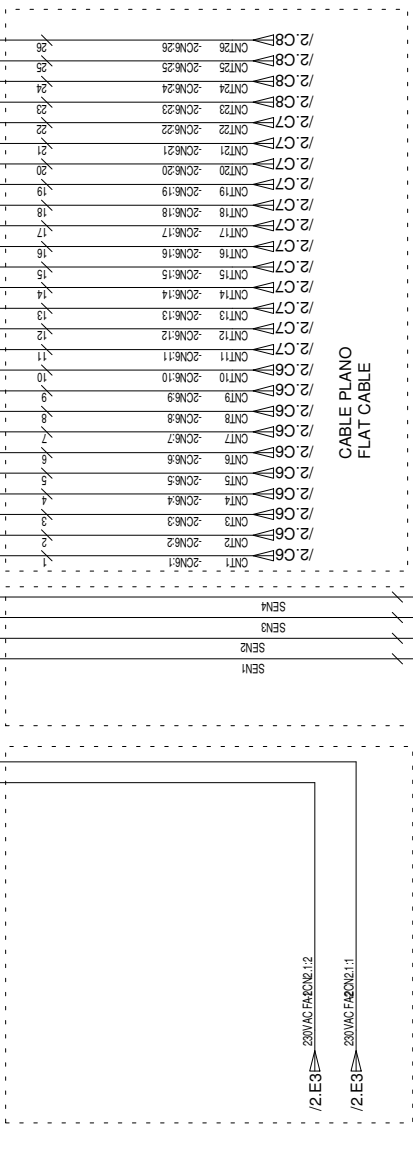
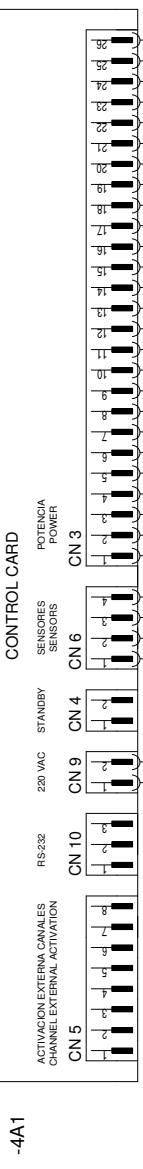

SISTEMA INYECCION AIRE SECO
 DRY AIR INJECTION SYSTEM
 INCORPORAR EN EQUIPOS PUR
 Ref: 616001930

Ref: 404000490

Ref: 600193

Ref: 616001930

Ref: 616001930

Ref: 616001930

Ref: 600175

Ref: 616001930

Ref: 600175

Ref: 600175

Ref: 600175

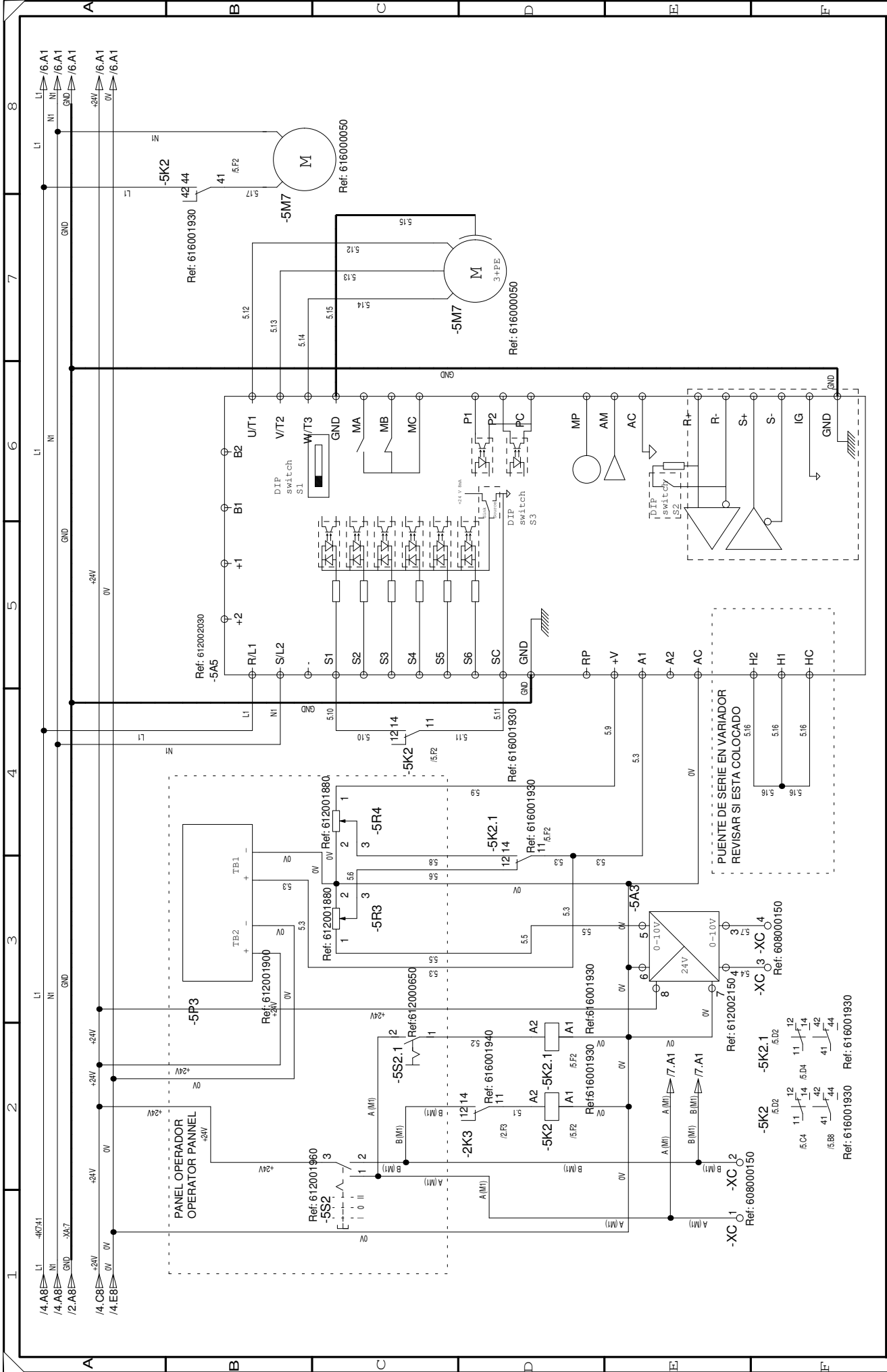

FECHA / DATE		NOMBRE / NAME	
23/01/2008		JESUS ZAPATA	
29/01/2009		JESUSZ	
EQUIPO/EQUIPMENT		DENOMINACIÓN / NAME	
MICRON 32 GEAR		CABLEADO DEL CIRCUITO DE MOTOR M1	
2 MOTORES PT100		WIRING OF THE MOTOR CIRCUIT M1	
DISP. :	SITC. :	HOJA / SHEET :	
101300300E		5 7	
REFERENCIA / REFERENCE		HOJA / SHEET :	
		5 7	



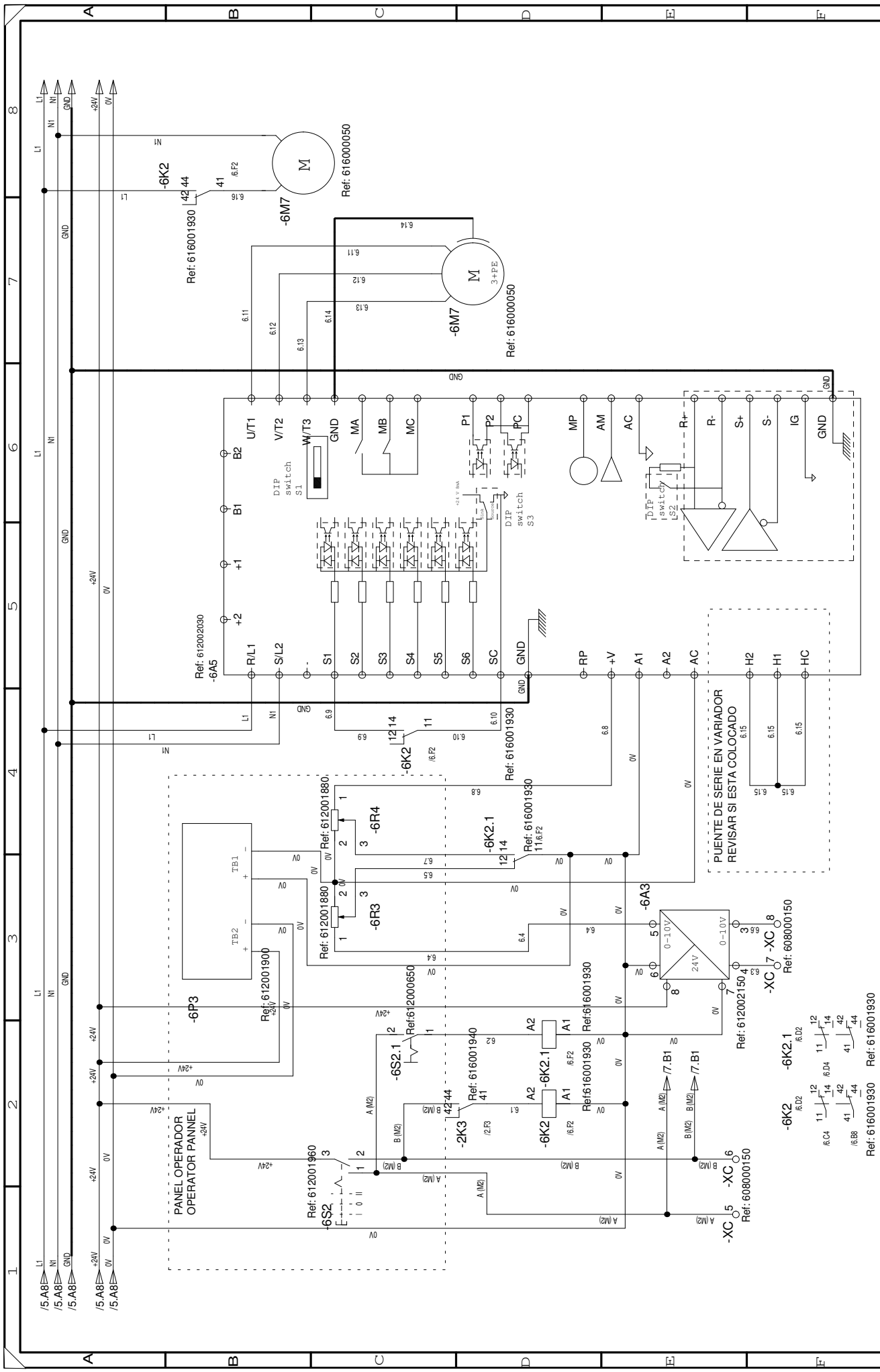

EQUIPO/EQUIPMENT MICRON 32 GEAR 2 MOTORES PT100		DISP.: REPUBLICA VENEZUELANA 101300300E	SIIC.: HOJA/SHEET 1 6 / 7
denominación / name CABLEADO DEL CIRCUITO DE MOTOR M2 WIRING OF THE MOTOR CIRCUIT M2			
		FECHA / DATE 25/01/2008 MODIFICADO/PROCESADO 29/01/2009 CLIENTE/CUSTOMER JESUS ZAPATA JESUSZ	
NOMBRE / NAME JESUS ZAPATA		Ref: 616001930 Ref: 616001930	

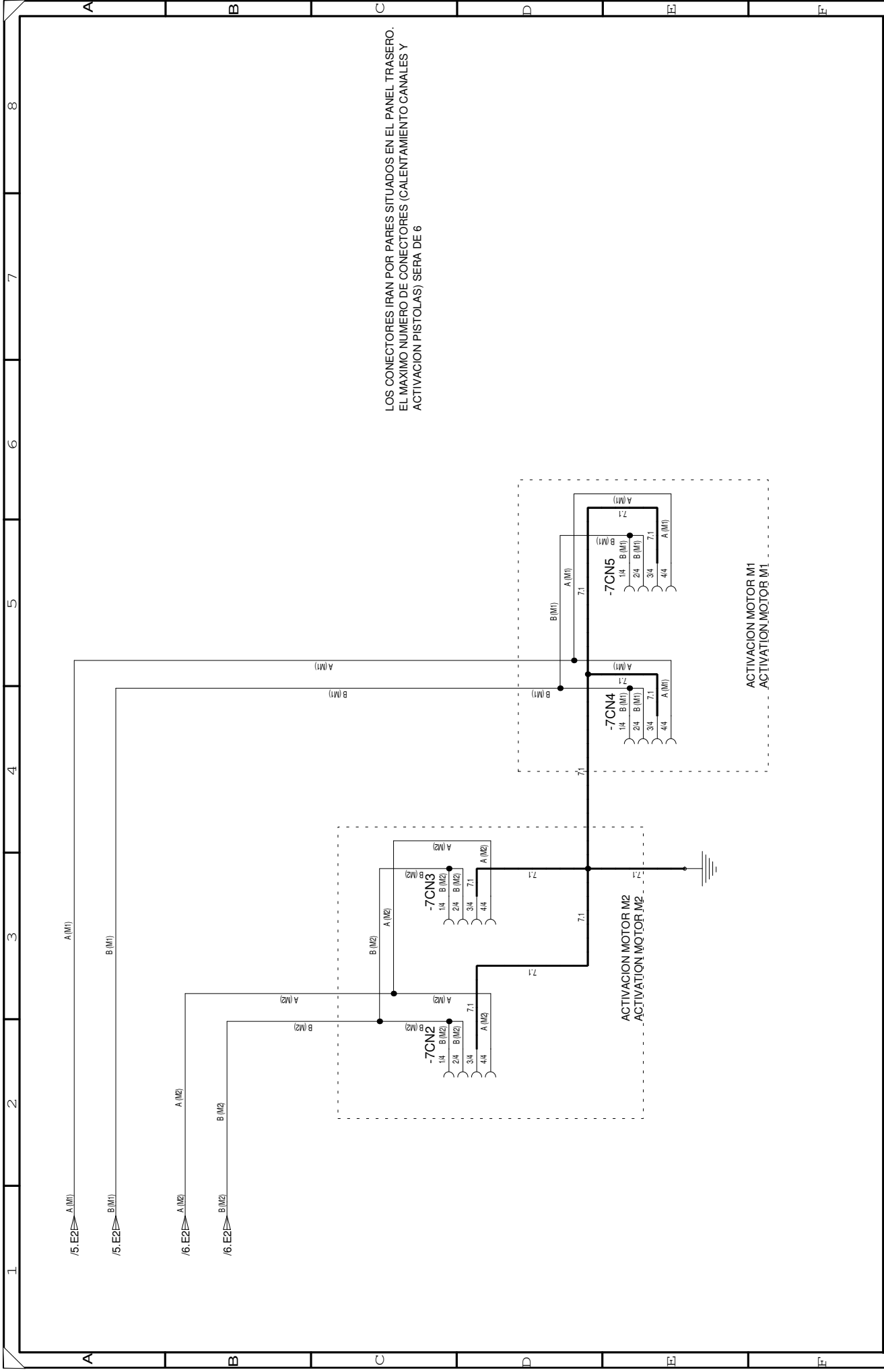

FECHA / DATE	29/01/2008	DISENOS/DRAWN	JESUS ZAPATA	NOBRE/NAME	meler®		DENOMINACIÓN / NAME	EQUIPO / EQUIPMENT		DISP. :	S.I.C. :
MODIFICADO / MODIFIED	29/01/2009	CLIENTE / CUSTOMER	JESUSZ			CONEXIONES ACTIVACION POR PISTOLA CONNECTIONS ACTIVATION BY GUN		MICRON 32 GEAR 2 MOTORES PT100		REFERENCIA / REFERENCE	101300300E
									HOJA / SHEET : 7 7		

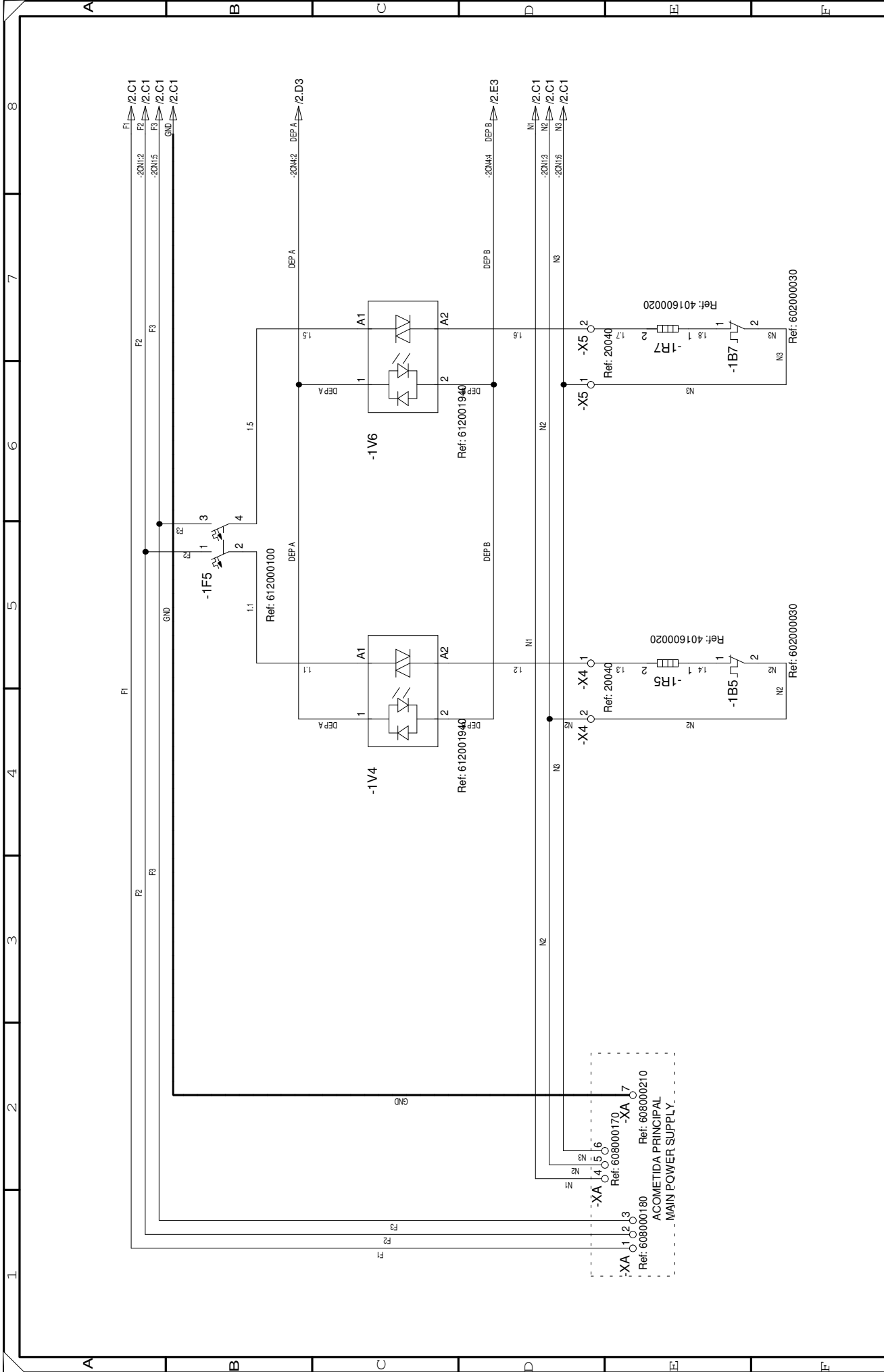

FECHA / DATE		NOMBRE / NAME	
22/01/2009		JESUS ZAPATA	
23/01/2009		JESUSZ	
DISEÑADO/DRAWN		EQUIPO/EQUIPMENT	
MODIFICADO/MODIFIED		MICRON 32 GEAR	
CLIENTE/CUSTOMER		1 MOTOR N120	
		DISP.:	SITC.:
		REFERENCIA/REFERENCE	
		101300340E	
		HOJA/SHEET:	1 7
		HOYAJ/SHEET#	

DENOMINACIÓN / NAME
 CABLEADO DEL CIRCUITO DE POTENCIA
 WIRING OF THE POWER CIRCUIT



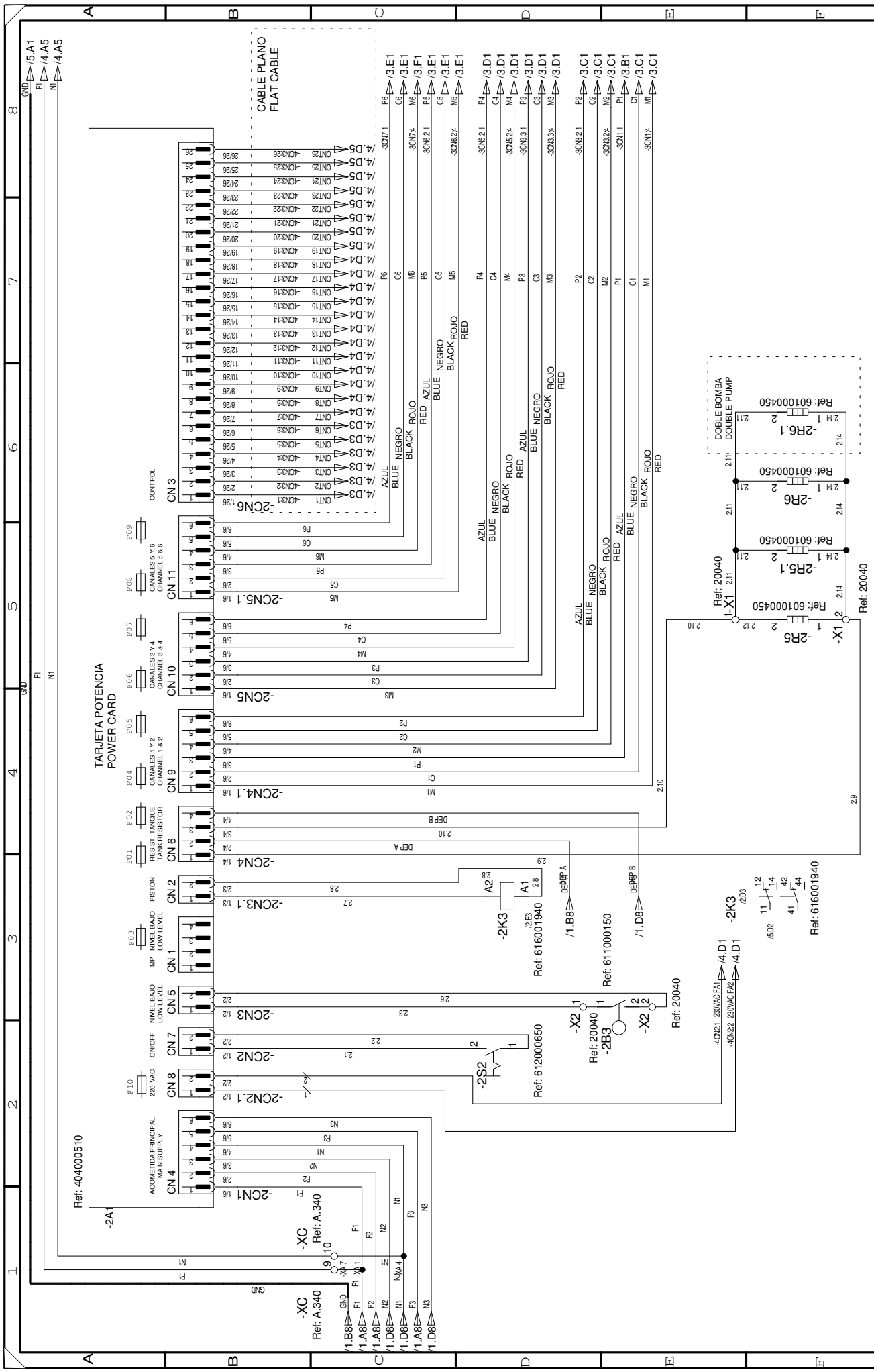

DENOMINACIÓN / NAME CABLEADO DEL CIRCUITO DE POTENCIA WIRING OF THE POWER CIRCUIT		EQUIPO / EQUIPMENT MICRON 32 GEAR 1 MOTOR NI120	
FECHA / DATE 14/01/2008 23/01/2009		DISP. / DISP. 2 7	
NOMBRE / NAME JESUS ZAPATA JESUSZ		SIIC. / SIIC. 101300340E	
DIBUJADO / DRAWN MODIFICADO / MODIFIED CLIENTE / CUSTOMER		REPÚBLICA / REPUBLIC 101300340E HOJA / SHEET	



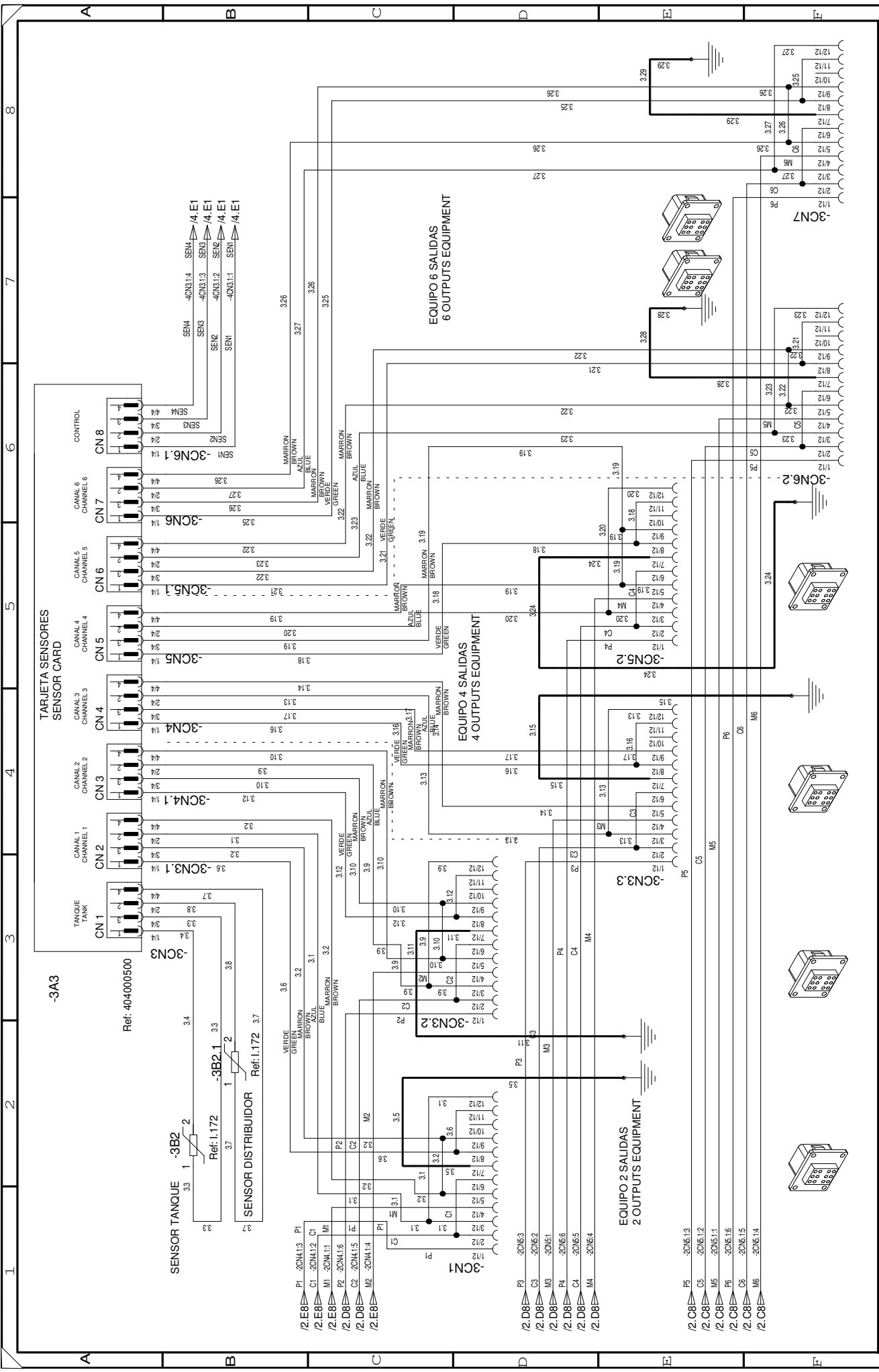

FECHA / DATE		NOMBRE / NAME		DENOMINACIÓN / NAME		EQUIPO / EQUIPMENT		DISP. : S.I.C. :	
28/01/2008		JESUS ZAPATA		CABLEADO DEL CIRCUITO DE SENSORES WIRING OF THE SENSOR CIRCUIT		MICRON 32 GEAR 1 MOTOR N120		101300340E	
23/01/2009		JESUSZ						HOJA / SHEET : 3 7	
CLIENTE / CUSTOMER								MODIFICADO / MODIFIED	



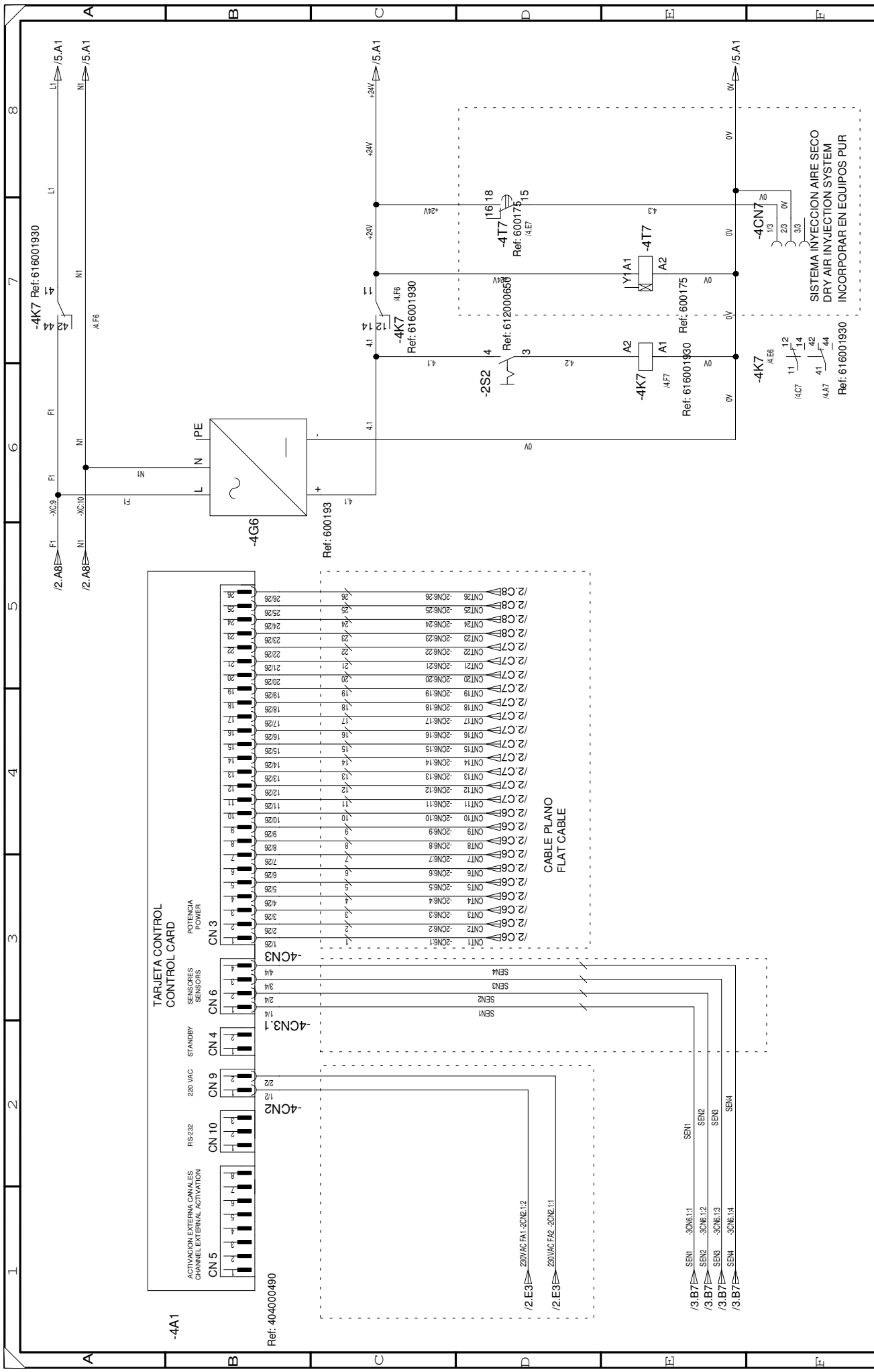

DISP.: SIIC.: REPERTEJO Y REFERENCIA: 101300340E HOJA/SHEET.: 4 7 HOJAS/SHEETS	
EQUIPO/EQUIPMENT MICRON 32 GEAR 1 MOTOR NI120	
DEMINACIÓN/NAME CABLEADO DEL CIRCUITO DE CONTROL WIRING OF THE CONTROL CIRCUIT	
	
FECHA/DATE 21/01/2008 23/01/2009	NOMBRE/NAME JESUS ZAPATA JESUSZ
DIBUJADO/DRAWN MODIFICADO/PROCESSED CLIENTE/CUSTOMER	Ref: 404000490

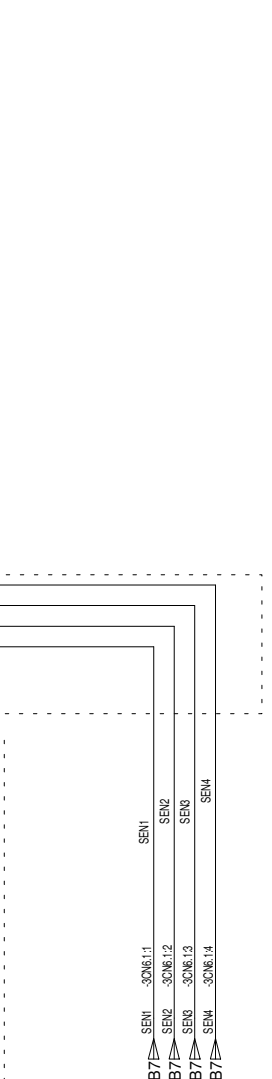
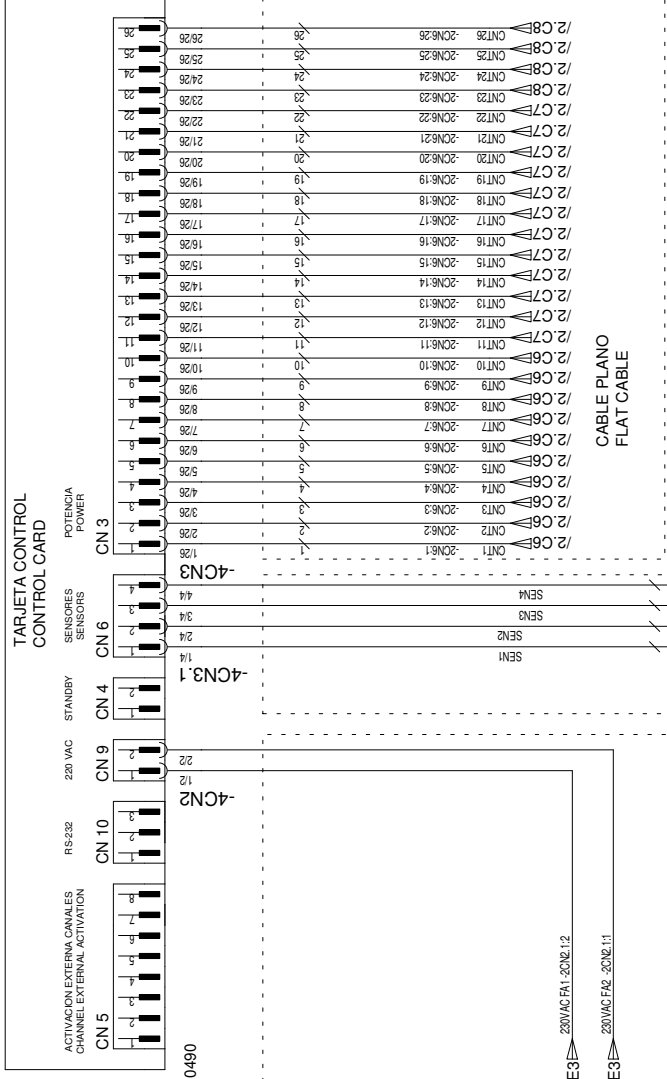

SISTEMA INYECCION AIRE SECO
 DRY AIR INJECTION SYSTEM
 INCORPORAR EN EQUIPOS PUR
 Ref: 616001930

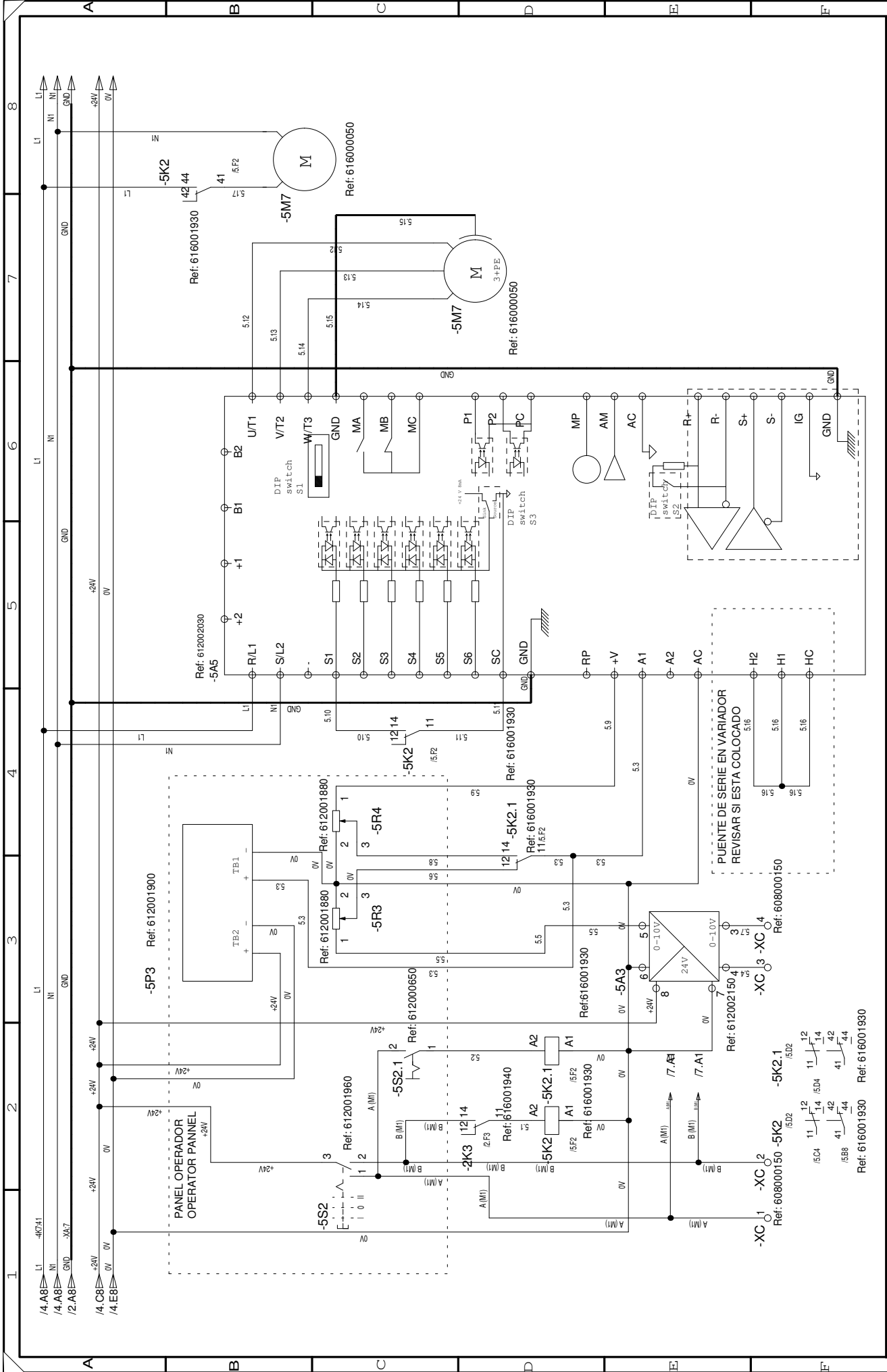

FECHA / DATE		NOMBRE / NAME	
23/01/2008		JESUS ZAPATA	
29/01/2009		JESUSZ	
DISEÑO/DRAWN		MODIFICADO/MODIFIED	
CLIENTE/CUSTOMER		EQUIPO/EQUIPMENT	
		MICRON 32 GEAR 1 MOTOR N120	
DENOMINACIÓN / NAME		DISP.: S.I.C.:	
CABLEADO DEL CÍRCULO DE MOTOR M1 WIRING OF THE MOTOR CIRCUIT M1		REFERENCIA / REFERENCE 101300340E	
meler®		HOJA / SHEET: 5 7	
Ref: 616001930		Ref: 616001930	

A		B		C		D		E		F								
1	2	3	4	5	6	7	8											
DIBUJANDO/DRAWN			FECHA / DATE			NOMBRE / NAME			DENOMINACIÓN / NAME			EQUIPO / EQUIPMENT			DISP.:		SIIC.:	
MODIFICADO/MODIFIED			29/01/2008			JESUS ZAPATA			RESERVA			MICRON 32 GEAR			REPERTEJO/REPERIENCE		101300340E	
CLIENTE/CUSTOMER			23/01/2009			JESUSZ			RESERVE			1 MOTOR N1120			HOJA/SHEET:		6 7	
meler®																		

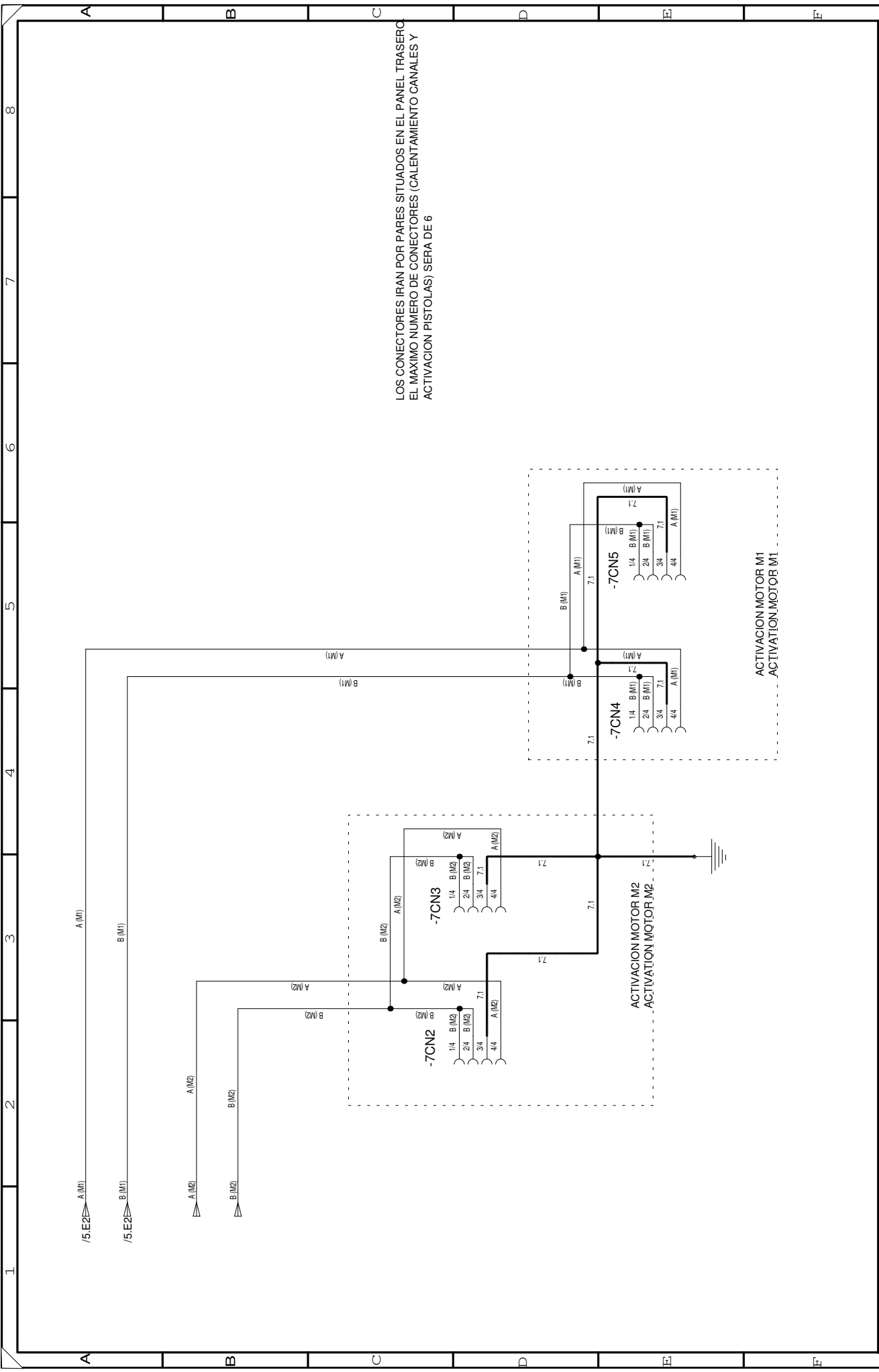

FECHA / DATE	29/01/2008	NUMBRE / NAME	JESUS ZAPATA	EQUIPO / EQUIPMENT	MICRON 32 GEAR 1 MOTOR N1120	DISP. : 101300340E	SITC. :
DISEÑADO / DRAWN	23/01/2009	JESUSZ	HOJA / SHEET				
MODIFICADO / MODIFIED							
CLIENTE / CUSTOMER							

DENOMINACIÓN / NAME:
CONEXIONES ACTIVACION POR PISTOLA
CONNECTIONS ACTIVATION BY GUN



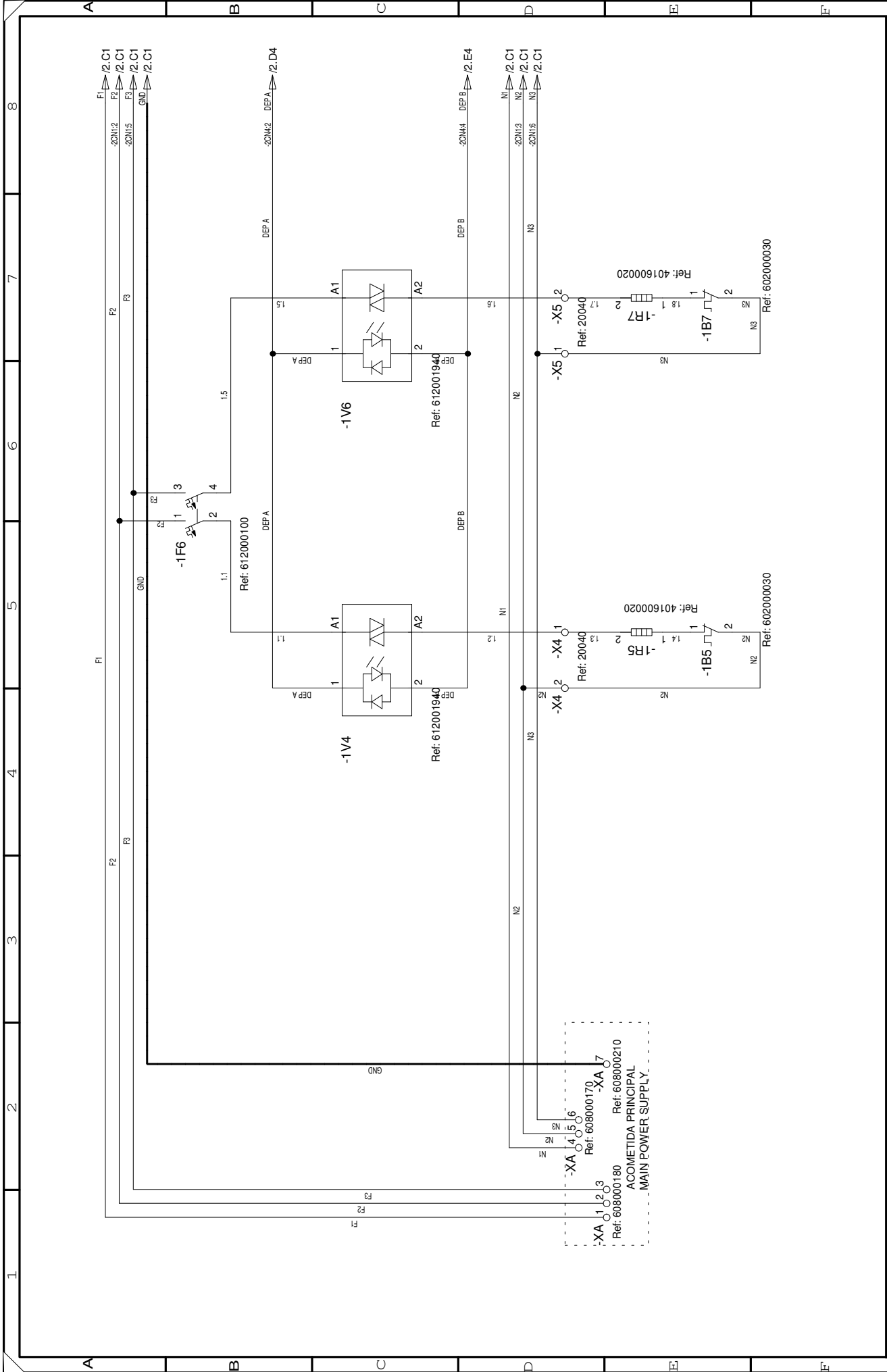

FECHA / DATE	NOMBRE / NAME	EQUIPO / EQUIPMENT	DISP. : REFERENCIA / REFERENCE	SITC. :
22/01/2009	JESUS ZAPATA	MICRON 32 GEAR	101300420E	
23/01/2009	JESUSZ	2 MOTORES N1120		
CLIENTE / CUSTOMER				HOJA / SHEET 1 7



DENOMINACIÓN / NAME
 CABLEADO DEL CIRCUITO DE POTENCIA
 WIRING OF THE POWER CIRCUIT

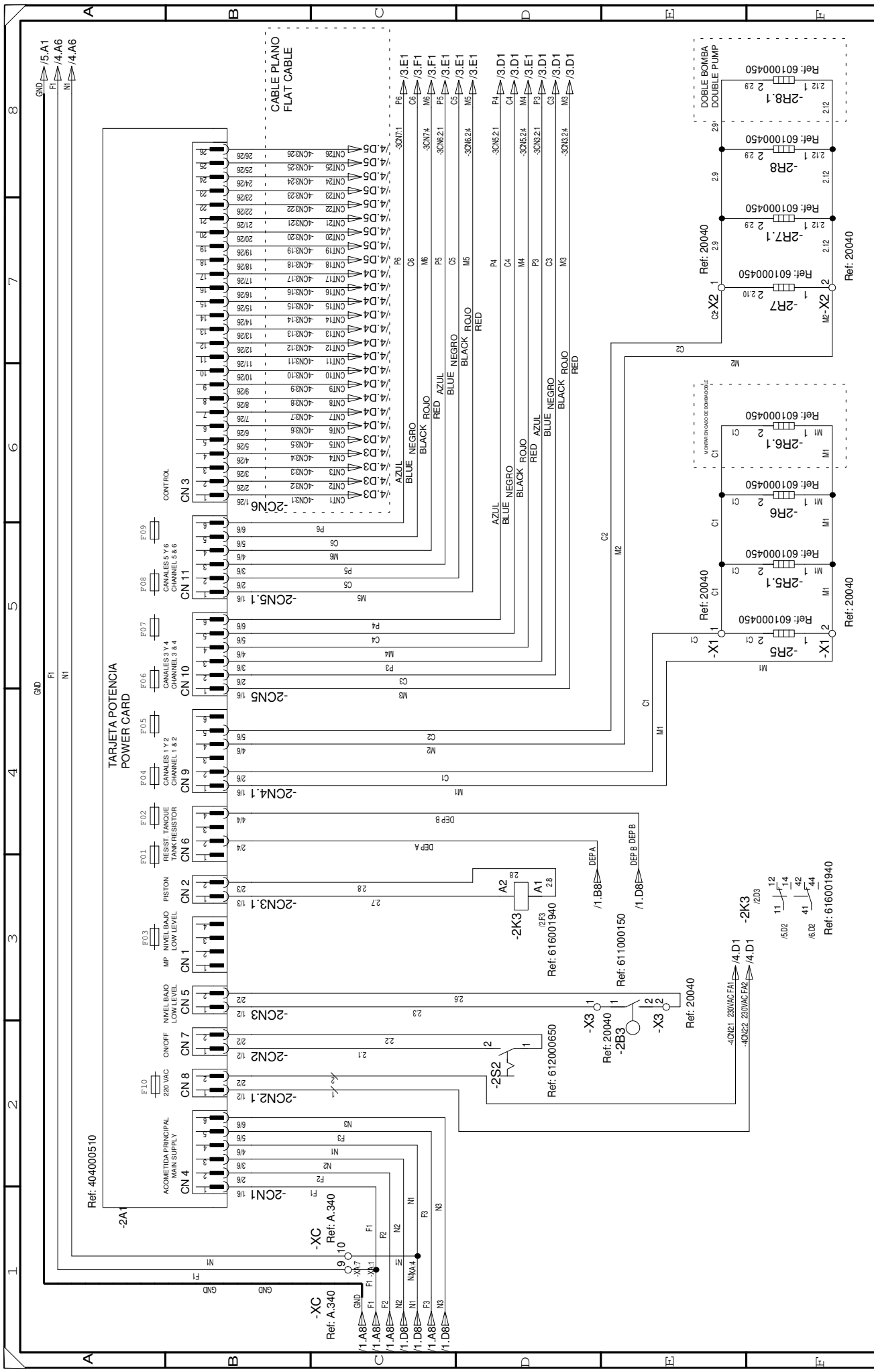

DISP.: SIIC.: REPERICION/REPERIENCE: 101300420E		HOJA/SHEET: 2 / 7	
EQUIPO/EQUIPMENT: MICRON 32 GEAR 2 MOTORES NI120		DEMINACION/NAME: CABLEADO DEL CIRCUITO DE POTENCIA WIRING OF THE POWER CIRCUIT	
FECHA/DATE: 14/01/2008 23/01/2009		NOMBRE/NAME: JESUS ZAPATA JESUSZ	
DIBUJADO/DRAWN: MODIFICADO/MODIFIED:		CLIENTE/CUSTOMER:	



Ref: 616001940

Ref: 20040

Ref: 612000650

Ref: 616001940

Ref: 611000150

Ref: 616001940

Ref: 616001940

Ref: 20040

Ref: 20040

Ref: 601000450

Ref: 601000450

Ref: 601000450

Ref: 601000450

Ref: 601000450

Ref: 601000450

Ref: 601000450

Ref: 601000450

Ref: 601000450

Ref: 601000450

Ref: 601000450

Ref: 601000450

Ref: 601000450

Ref: 601000450

Ref: 601000450

Ref: 601000450

Ref: 601000450

Ref: 601000450

Ref: 601000450

Ref: 601000450

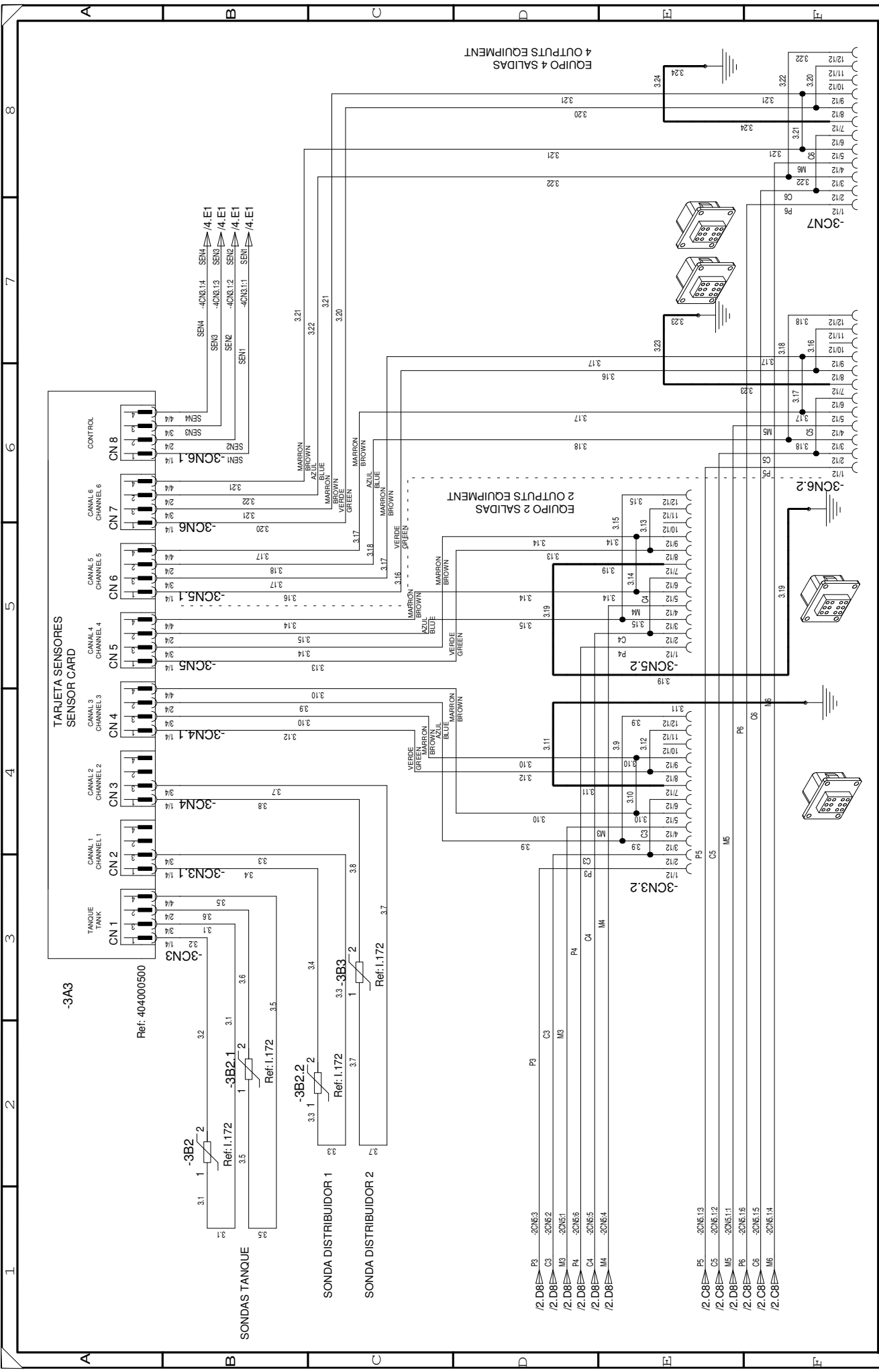

DISP.:	S.I.C.:
101300420E	
REFERENCIA / REFERENCE	
HOJA / SHEET:	3
	7
	HOJA# / SHEET#

EQUIPO/EQUIPMENT
MICRON 32 GEAR
2 MOTORES NI120

DENOMINACIÓN / NAME:
CABLEADO DEL CIRCUITO DE SENSORES
WIRING OF THE SENSOR CIRCUIT



FECHA / DATE	NOMBRE / NAME
21/01/2008	JESUS ZAPATA
23/01/2009	JESUSZ
DISEÑADO / DRAWN	
MODIFICADO / MODIFIED	
CLIENTE / CUSTOMER	

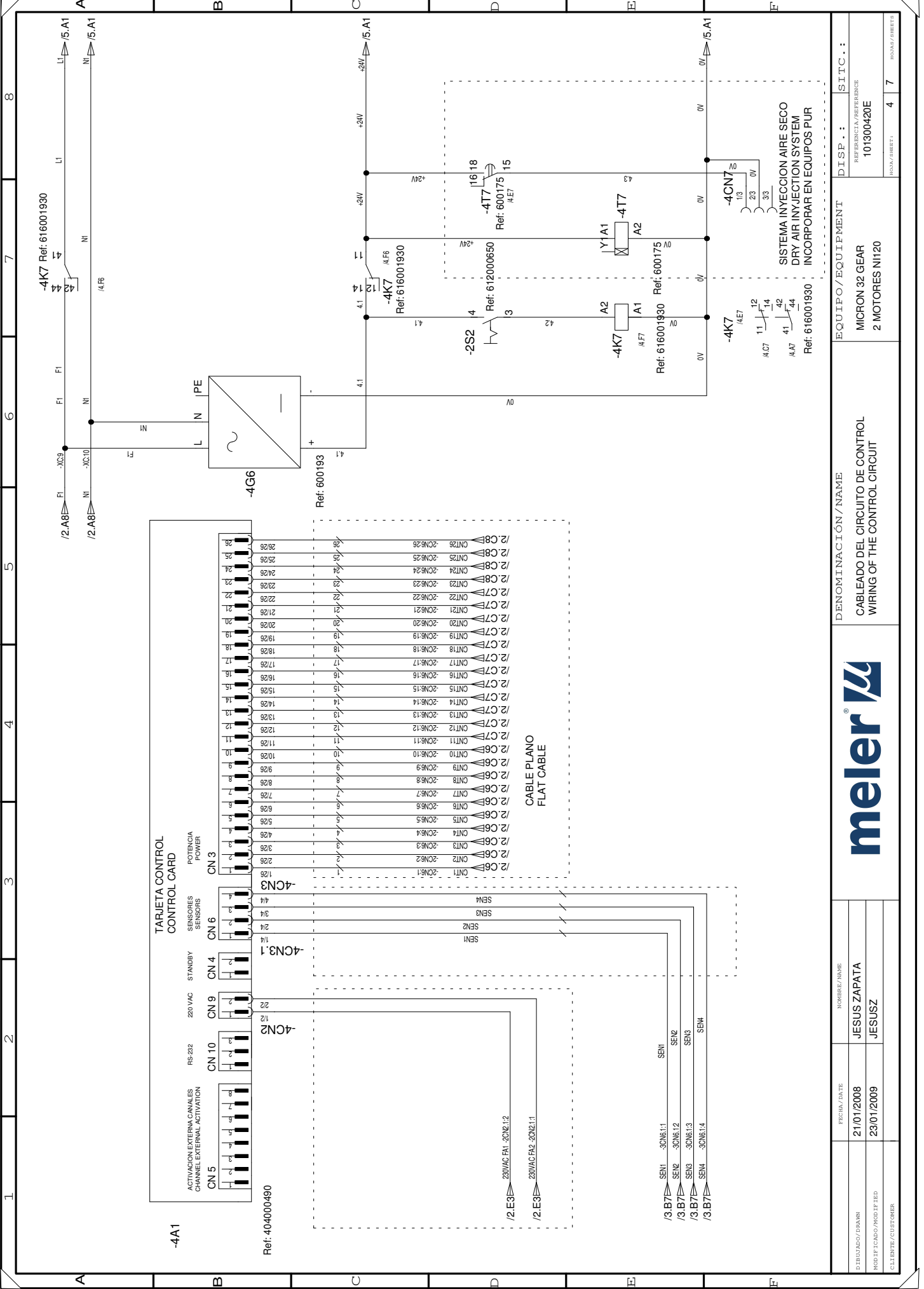

DENOMINACIÓN / NAME CABLEADO DEL CIRCUITO DE CONTROL WIRING OF THE CONTROL CIRCUIT		EQUIPO / EQUIPMENT MICRON 32 GEAR 2 MOTORES NI/20		DISP. : 101300420E	SIIC. : 4
FECHA / DATE 21/01/2008 23/01/2009		NOMBRE / NAME JESUS ZAPATA JESUSZ		REPERTEJO / REFERENCIE 101300420E	
DIBUJADO / DRAWN MODIFICADO / MODIFY CLIENTE / CUSTOMER		HOJA / SHEET : 4		TOTAL / SHEETS : 7	



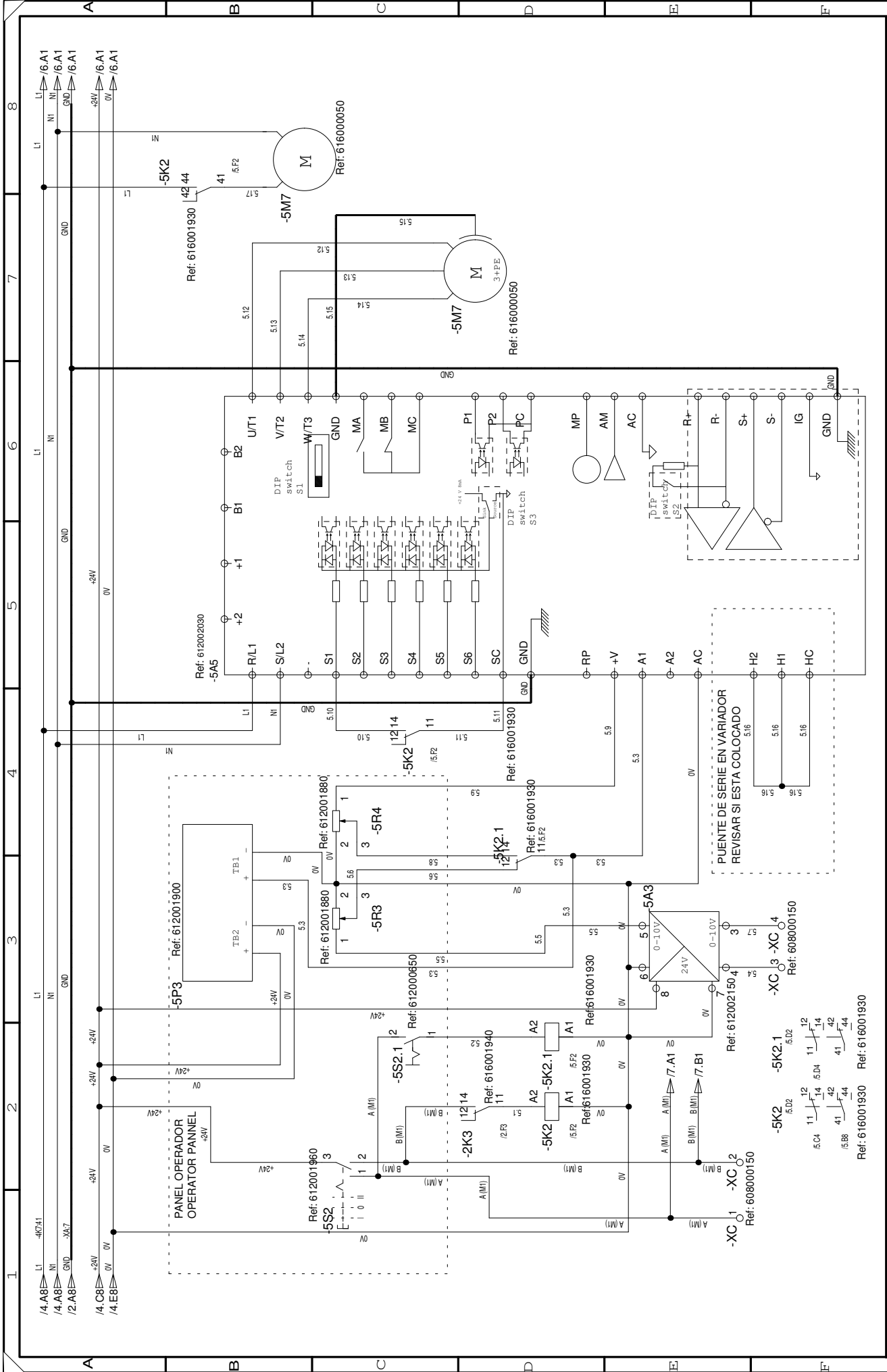

FECHA / DATE	23/01/2008	FECHA / DATE	29/01/2009
DISEÑO / DRAWN	JESUS ZAPATA	MODIFICADO / MODIFIED	JESUSZ
CLIENTE / CUSTOMER			
DENOMINACIÓN / NAME		EQUIPO / EQUIPMENT	
CABLEADO DEL CIRCUITO DE MOTOR M1 WIRING OF THE MOTOR CIRCUIT M1		MICRON 32 GEAR 2 MOTORES NI120	
NOMBRE / NAME		DISP. / REFERENCE	S.I.C. /
		101300420E	
		HORA / HOURS	5 7



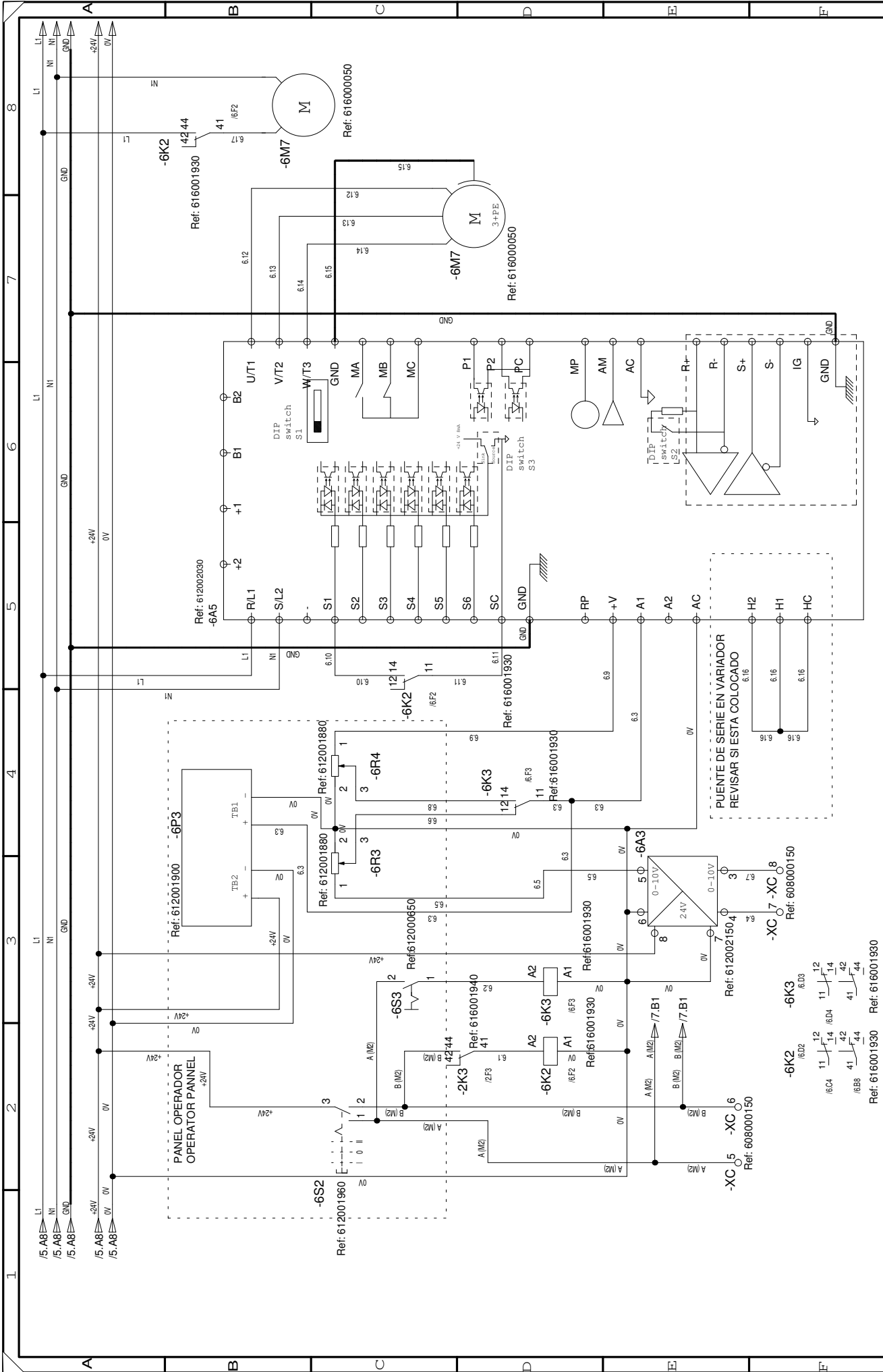

DISP.: SIIC.: REPERTEJO Y REFERENCIA: 101300420E HOJA/SHEET: 6 7		EQUIPO/EQUIPMENT: MICRON 32 GEAR 2 MOTORES NI/20	
 denominación / NAME			
 CABLEADO DEL CIRCUITO DE MOTOR M2 WIRING OF THE MOTOR CIRCUIT M2			
FECHA / DATE 25/01/2008 29/01/2009		NOMBRE / NAME JESUS ZAPATA JESUSZ	
DIBUJADO / DRAWN MODIFICADO / MODIFIED CLIENTE / CUSTOMER			

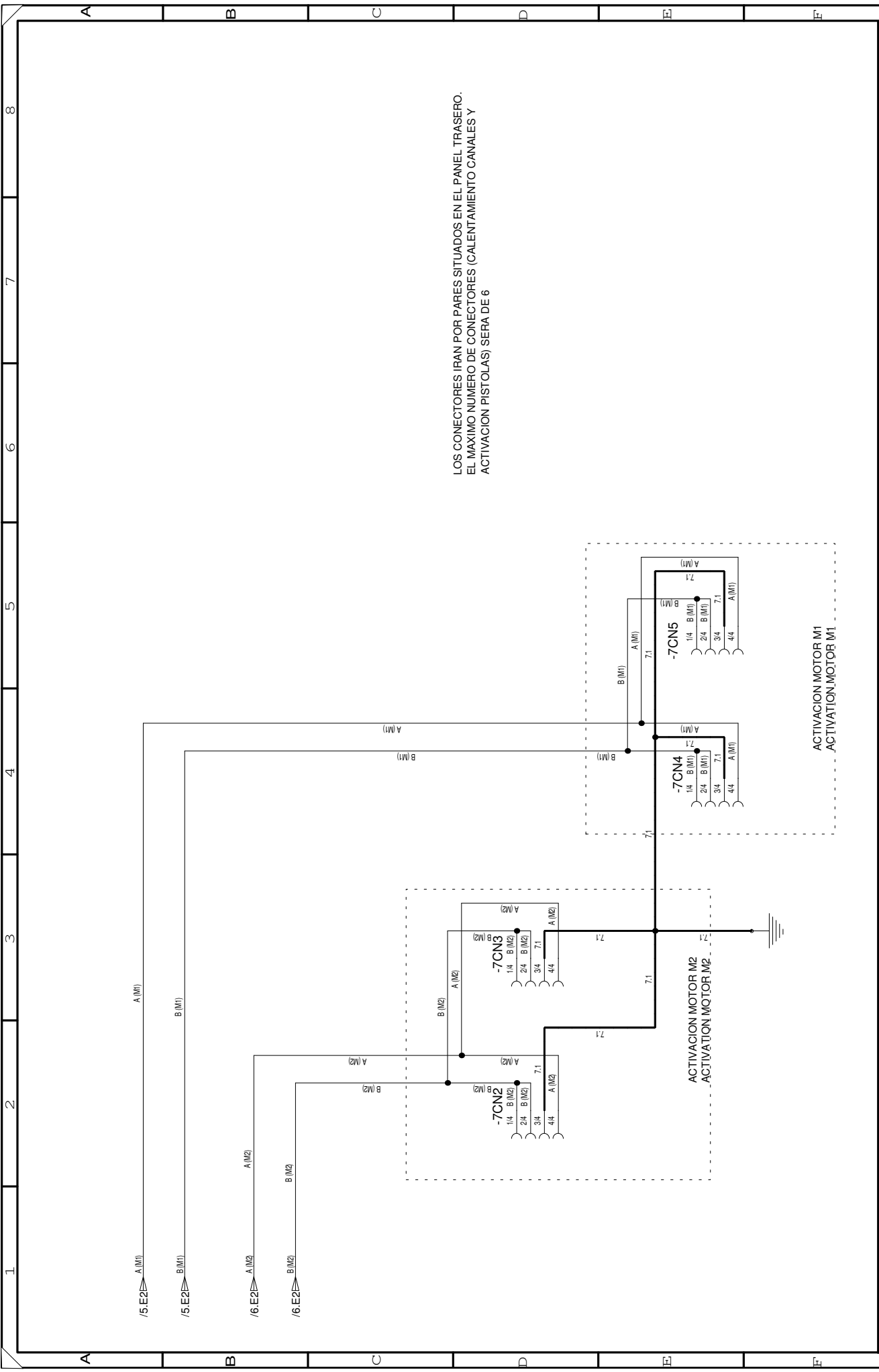

FECHA / DATE	29/01/2008	NOMBRE / NAME	JESUS ZAPATA
DISEÑADO / DRAWN	23/01/2009	CLIENTE / CUSTOMER	JESUSZ
MODIFICADO / MODIFIED			
EQUIPO / EQUIPMENT		DENOMINACIÓN / NAME	
MICRON 32 GEAR		CONEXIONES ACTIVACION POR PISTOLA	
2 MOTORES NH120		CONNECTIONS ACTIVATION BY GUN	
DISP. :	101300420E	S.I.C. :	
REFERENCIA / REFERENCE		HOJA / SHEET :	7
			7



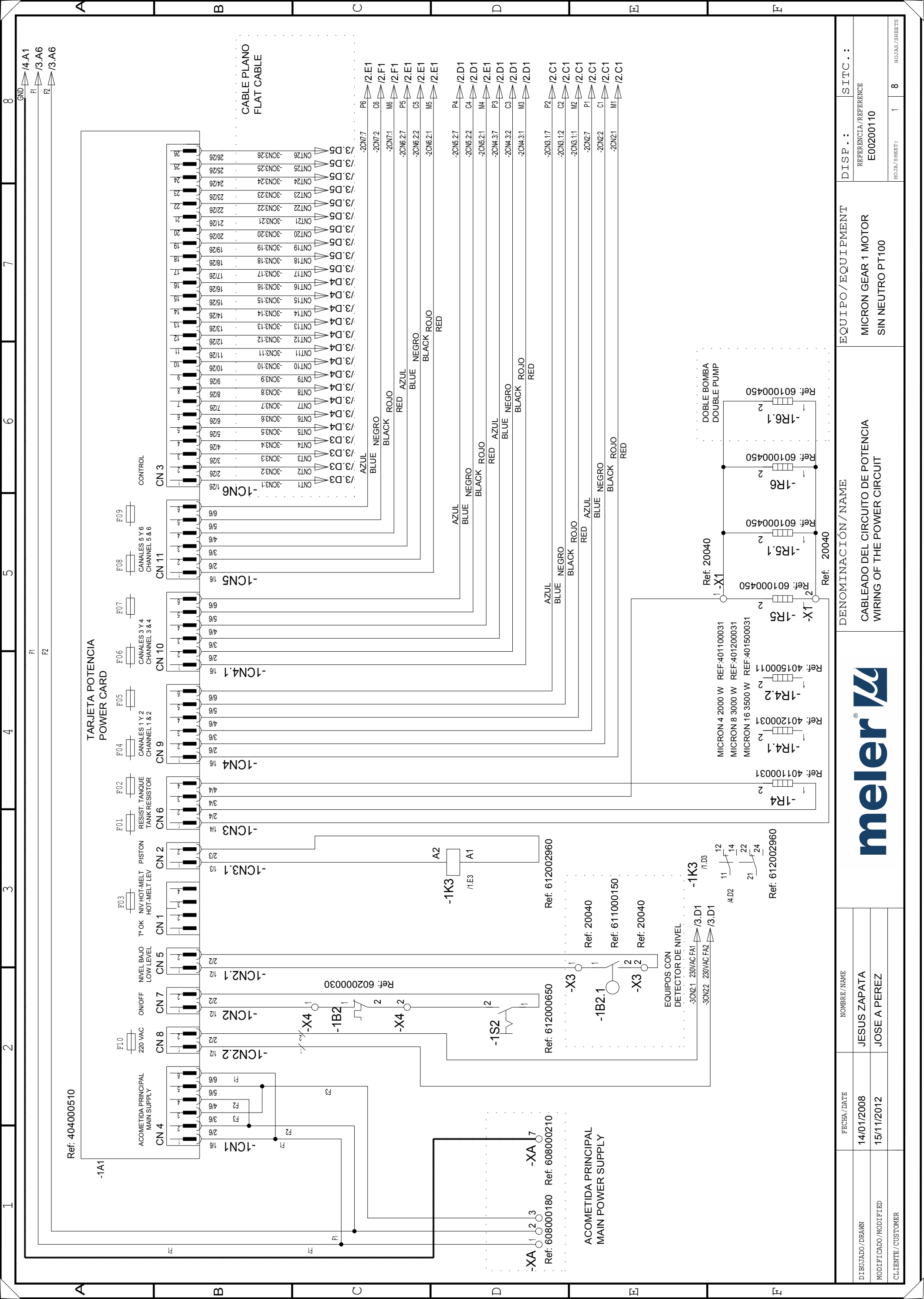

DISP.:	SITC.:
REFERENCIA/REFERENCE	E00200110
HORA/SHEET:	1 / 8

EQUIPO/EQUIPMENT
MICRON GEAR 1 MOTOR
SIN NEUTRO PT100

DENOMINACIÓN/NAME
CABLEADO DEL CIRCUITO DE POTENCIA
WIRING OF THE POWER CIRCUIT



FECHA/DATE	14/01/2008
NOMBRE/NAME	JESUS ZAPATA
DIBUJADO/DRAWN	JOSE A PEREZ
MODIFICADO/MODIFIED	
CLIENTE/CUSTOMER	

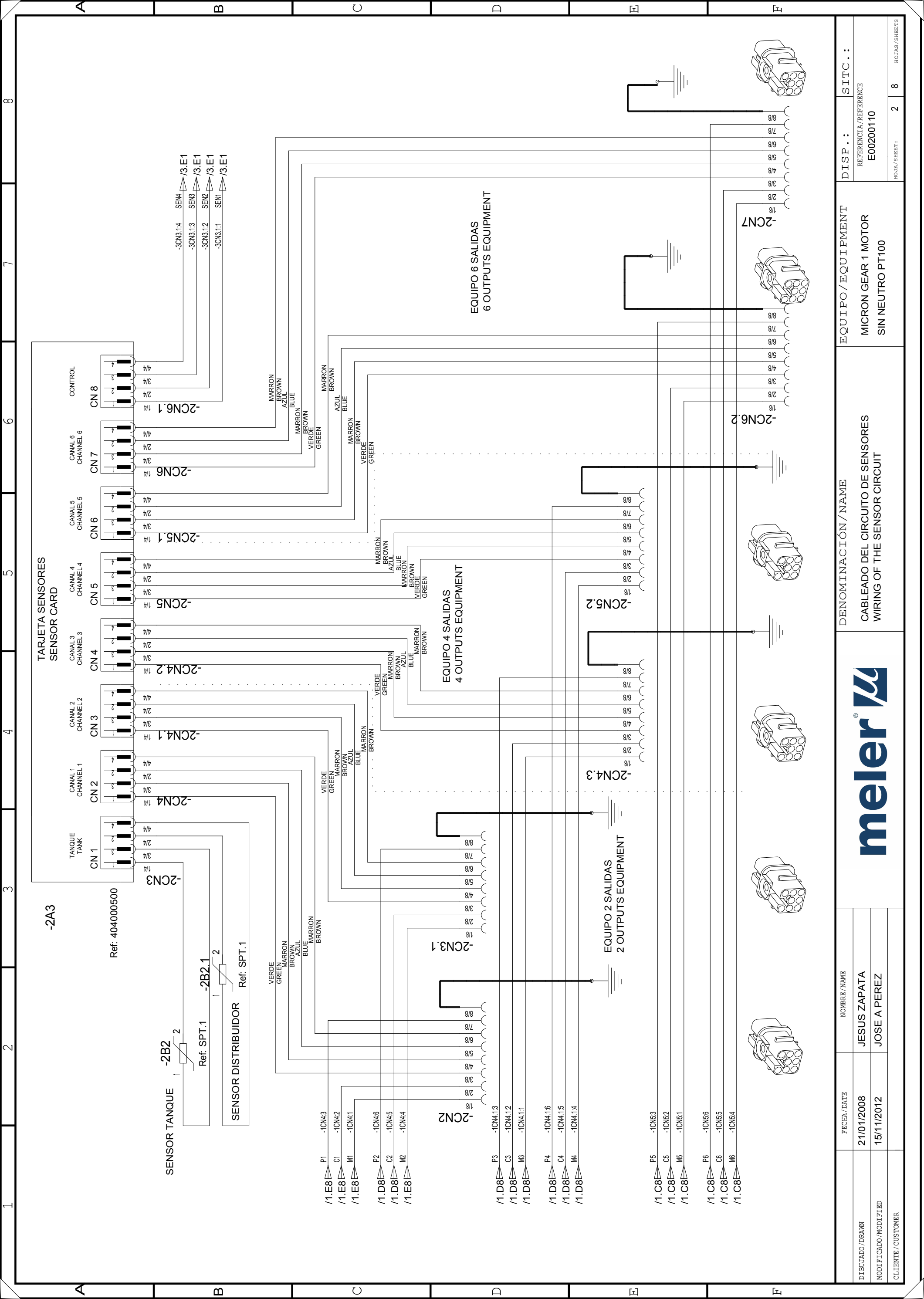

		DENOMINACIÓN / NAME CABLEADO DEL CIRCUITO DE SENSORES WIRING OF THE SENSOR CIRCUIT		EQUIPO / EQUIPMENT MICRON GEAR 1 MOTOR SIN NEUTRO PT100		DISP. : SITC. : REFERENCIA / REFERENCE E00200110	
FECHA / DATE 21/01/2008 15/11/2012		NOMBRE / NAME JESUS ZAPATA JOSE A PEREZ		HOURS / SHEETS 2 8		HOJA / SHEET	
DIBUJADO / DRAWN		MODIFICADO / MODIFIED		CLIENTE / CUSTOMER			

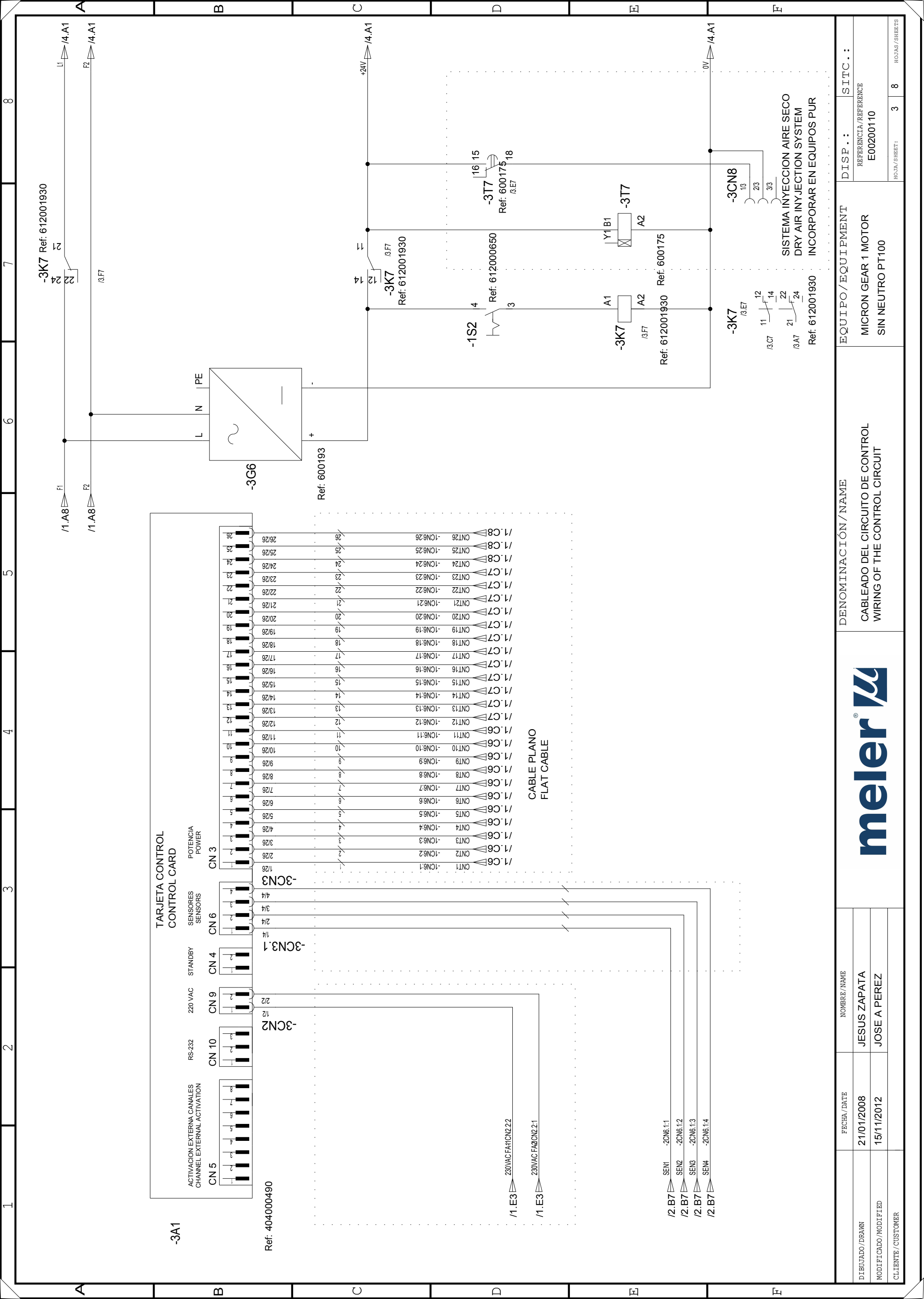

-3K7 Ref: 612001930

-3G6

Ref: 600193

-3K7 Ref: 612001930

-1S2

Ref: 612000650

-3K7 Ref: 612001930

-3CN8

SISTEMA INYECCION AIRE SECO
 DRY AIR INJECTION SYSTEM
 INCORPORAR EN EQUIPOS PUR

TARJETA CONTROL
 CONTROL CARD

-3A1

Ref: 404000490

CABLE PLANO
 FLAT CABLE

FECHA / DATE	NOMBRE / NAME	DENOMINACIÓN / NAME	EQUIPO / EQUIPMENT	DISP. .:	SITC. .:
21/01/2008	JESUS ZAPATA	CABLEADO DEL CIRCUITO DE CONTROL WIRING OF THE CONTROL CIRCUIT	MICRON GEAR 1 MOTOR SIN NEUTRO PT100	REFERENCIA / REFERENCE E00200110	
15/11/2012	JOSE A PEREZ			HORA / SHEET: 3	8
CLIENTE / CUSTOMER					



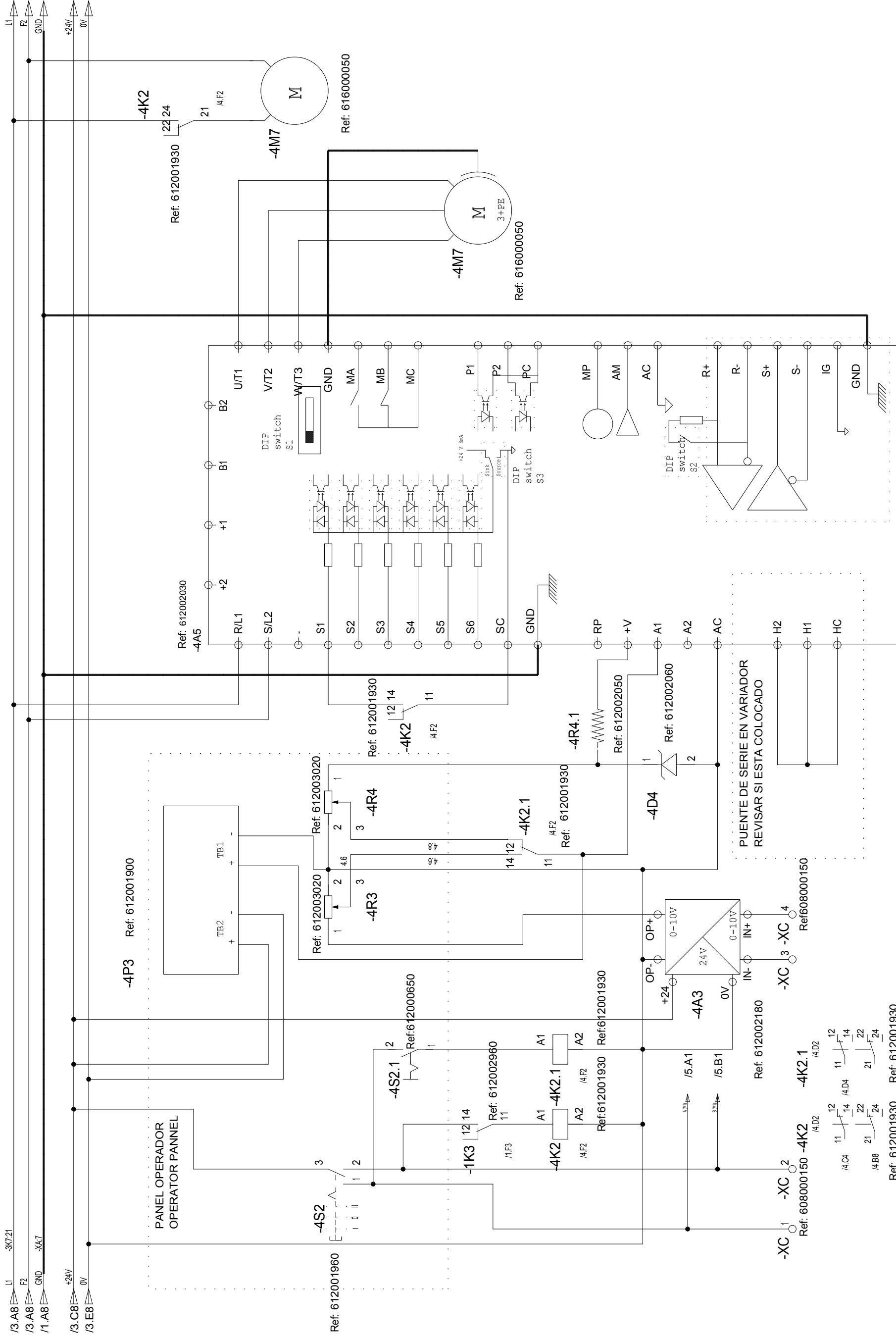

		DENOMINACIÓN / NAME CABLEADO DEL CÍJUTO DE MOTOR M1 WIRING OF THE MOTOR CIRCUIT M1		EQUIPO / EQUIPMENT MICRON GEAR 1 MOTOR SIN NEUTRO PT100		DISP. .: SITC. .: REFERENCIA / REFERENCE E00200110	
FECHA / DATE 23/01/2008 15/11/2012		NOMBRE / NAME JESUS ZAPATA JOSE A PEREZ		HOURS / SHEETS 4 8		HOJA / SHEET: 4 8	

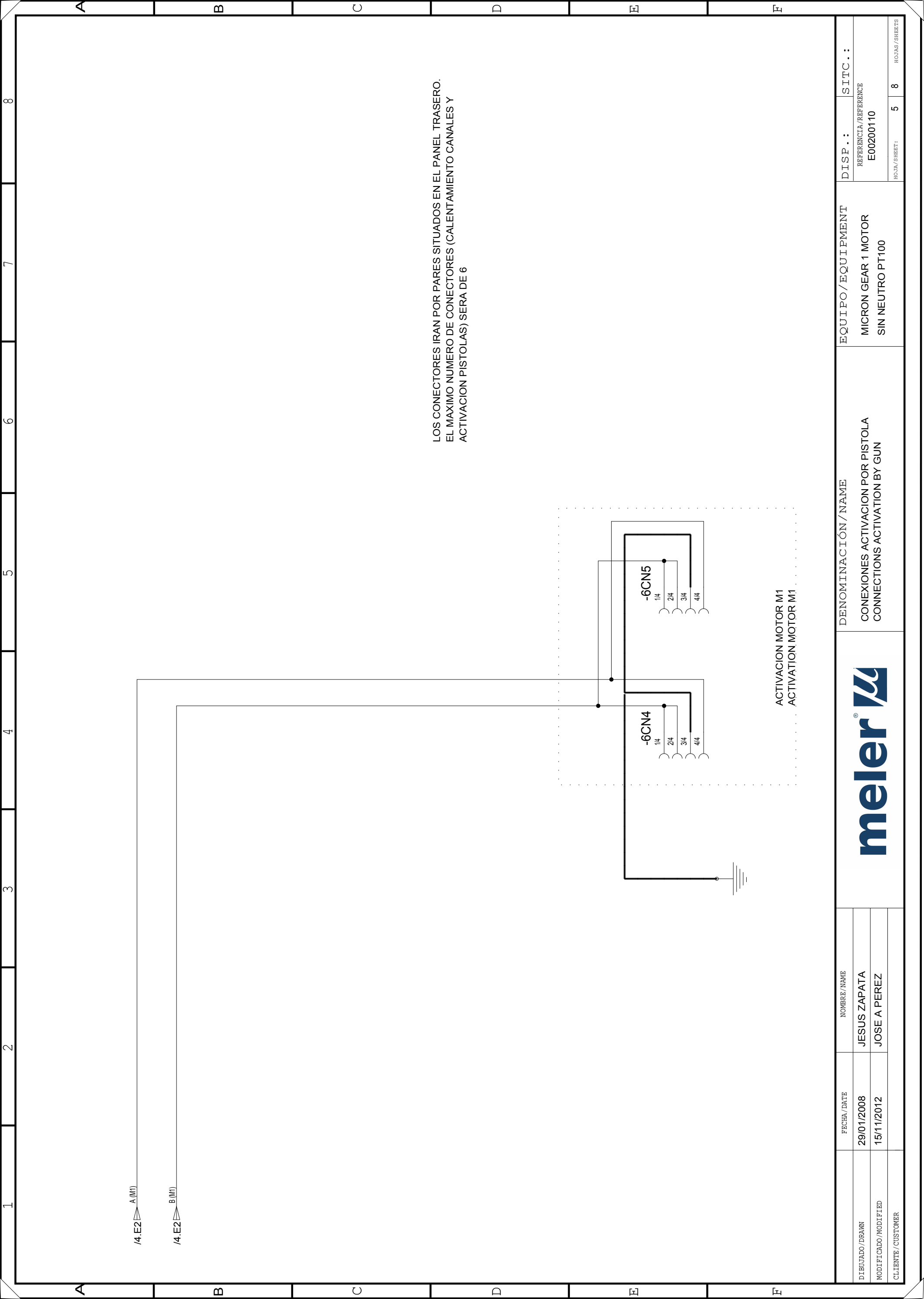

LOS CONECTORES IRAN POR PARES SITUADOS EN EL PANEL TRASERO.
 EL MAXIMO NUMERO DE CONECTORES (CALENTAMIENTO CANALES Y
 ACTIVACION PISTOLAS) SERA DE 6

ACTIVACION MOTOR M1
 ACTIVATION MOTOR M1

		DENOMINACIÓN / NAME		EQUIPO / EQUIPMENT		DISP. :		SITC. :	
NOMBRE / NAME JESUS ZAPATA JOSE A PEREZ		CONEXIONES ACTIVACION POR PISTOLA CONNECTIONS ACTIVATION BY GUN		MICRON GEAR 1 MOTOR SIN NEUTRO PT100		REFERENCIA / REFERENCE E00200110			
FECHA / DATE 29/01/2008 15/11/2012						HOJA / SHEET : 5		8	
DIBUJADO / DRAWN MODIFICADO / MODIFIED CLIENTE / CUSTOMER								HOURS / SHEETS	

8. PNEUMATIC DIAGRAM

Components list

Pneumatic by-pass valve control system

- 1 Pressure regulator 1-10 bar
- 2 Pressure gauge 0-10 bar
- 3 Pneumatic limit control valve

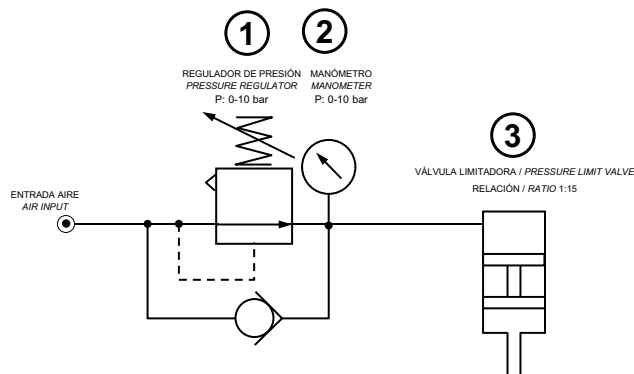

Air drying system

- 1 Filter – 1st stage, grade 7
- 2 Filter – 2nd stage, grade 5
- 3 Air dryer
- 4 3/2 solenoid valve with manual control
- 5 Pressure regulator 1-10 bar
- 6 Pressure gauge 0-10 bar
- 7 Output nozzle

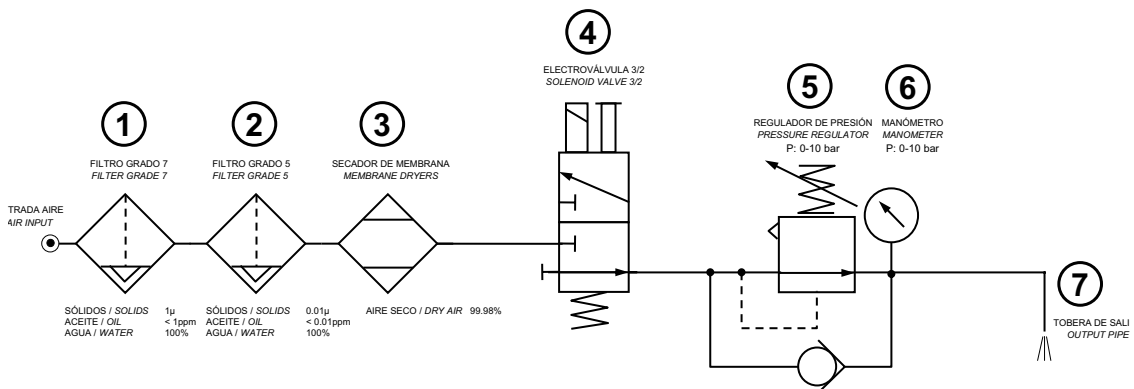

This page is intentionally left blank.

9. SPARE PARTS LIST

The most common spare parts list of the micron series adhesive melters is shown in this chapter to give you a quick and sure guideline to choose them.

The spare parts are listed by groups in a natural order as they are located on the units.

As a visual help the manual includes drawings of the components with a drawing number to easy find them through the list.

The list gives you the part number and description, showing if it is necessary, if the part number belongs to a 4, 8 or 16 liters unit.





This page is intentionally left blank.

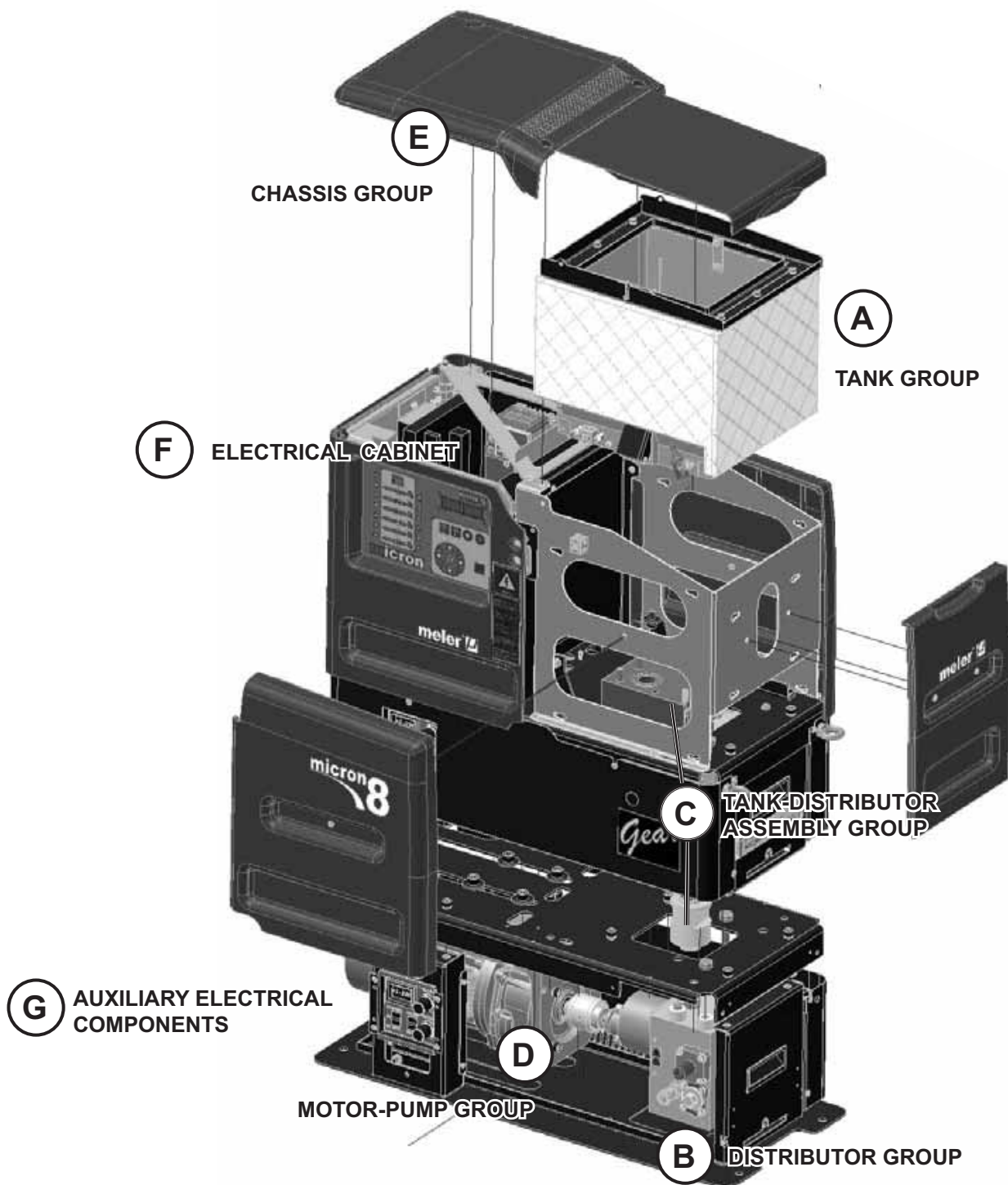



A. TANK GROUP

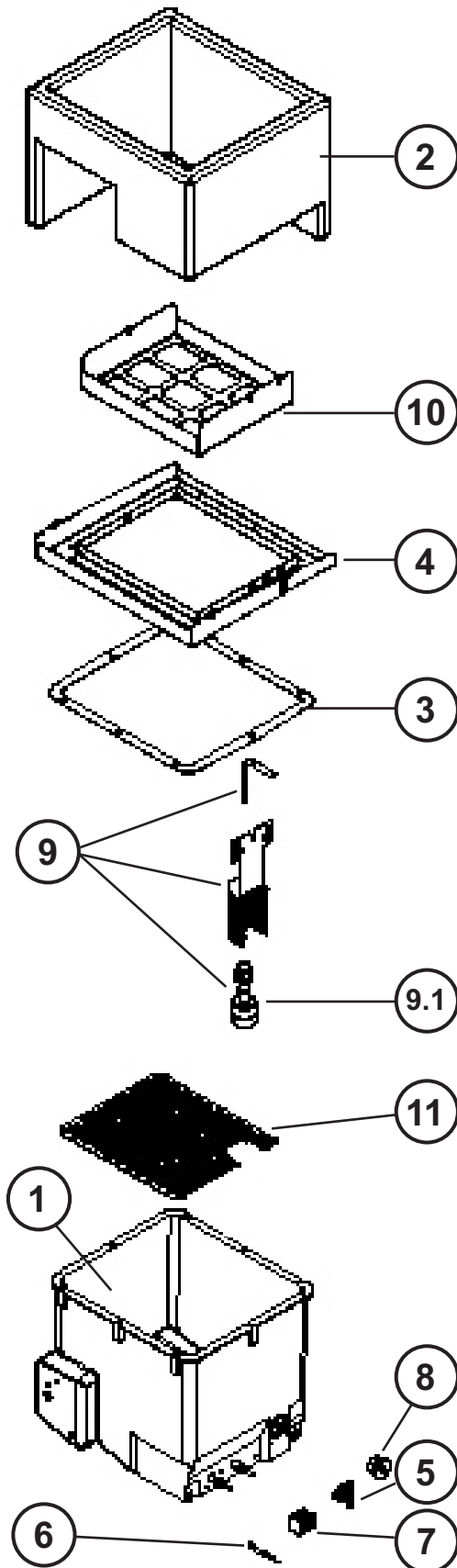

N°	Ref.	Description
1	150026170	Complete tank assembly micron4
1	150026190	Complete tank assembly micron8
1	150026210	Complete tank assembly micron16
1.1	150026180	PTFE coated tank micron4
1.1	150026200	PTFE coated tank micron8
1.1	150026220	PTFE coated tank micron16
2	150021610	Insulation mantle micron4
2	150021620	Insulation mantle micron8
2	150023030	Insulation mantle micron16
3	150024650	Tank gasket micron4
3	150024890	Tank gasket micron8
3	150025070	Tank gasket micron16
4	150024990	Tank port housing micron4
4	150024870	Tank port housing micron8
4	150025060	Tank port housing micron16
5	10030009	Safety thermostat 240°C
6	150022640	Tank RTD sensor Pt-100 micron
6	150022650	Tank RTD sensor Ni-120 micron
7	10030007	Tank hook-up fitting-electrical lead
8	150021790	Drain plug with o-ring
8.1	150021730	Drain plug o-ring
9	150024660	Level detector assembly micron4 (*)
9	150024880	Level detector assembly micron8 (*)
9	150025190	Level detector assembly micron16 (*)
9.1	150021920	Level detector micron
10	150025160	Tank safety grid micron4 (*)
10	150025170	Tank safety grid micron8 (*)
10	150025180	Tank safety grid micron16 (*)
11	150025200	Tank grid micron4
11	150025210	Tank grid micron8
11	150025220	Tank grid micron16
11	150025230	Tank grid w/level detector micron4
11	150025240	Tank grid w/level detector micron8
11	150025250	Tank grid w/level detector micron16

(*) optional

B. DISTRIBUTOR GROUP

N°	Ref.	Description	N°	Ref.	Description
1	150026260	Mechanical pressure valve assembly	13	150025260	Distributor filter body with o-ring micron
2	150026270	Pneumatic pressure valve assembly (*)	14	150025270	Distributor filter body o-ring micron
3	150026280	Mechanical pressure valve o-rings	15	10120095	Plug c/w o-ring compensation valve
4	150026290	Mechanical pressure valve spring	16	10120096	O-ring plug compensation valve
5	150026060	Pressure valve closure needle	17	10100082	Pump plug with o-ring
6	150026300	Pneumatic pressure valve o-rings (*)	18	10100083	Pump plug o-ring
7	150026310	Complete hydraulic outlets block	19	150026350	Heating element 3/8x177 300W
8	150026320	Hydraulic outlets block seat o-rings	20	150022660	Distributor RTD sensor Pt-100 micron
9	150026330	Complete purge valve	21	150022670	Distributor RTD sensor Ni-120 micron
10	150026340	Purge valve o-ring	22	150026440	Single pump-distributor plate seat o-rings
11	150029250	Distributor filter cartridge micron		10110030	'meler' pressure gauge (*)
12	150029240	Distributor filter assembly micron		10110031	Pressure regulator (*)
23	150029260	Distributor filter o-ring micron		10120021	Fast connection air input (*)

(*) opcional

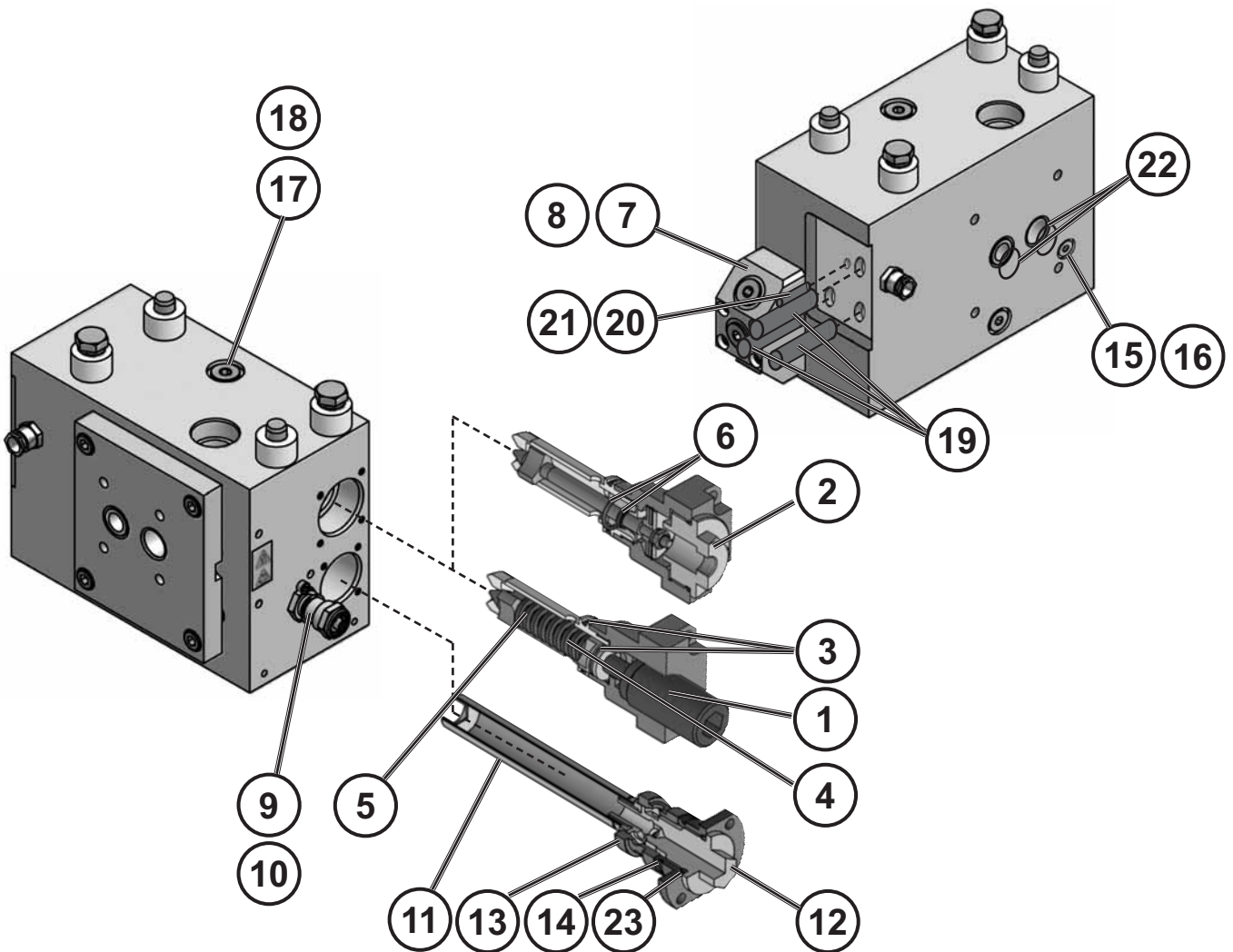

C. TANK-DISTRIBUTOR ASSEMBLY GROUP

N°	Ref.	Description
1	150026360	micron8/16 tank-distributor o-rings
2	150026370	micron4 tank-distributor o-rings
3	150026380	Same pumping groups assembly o-rings
4	150026390	Different pumping groups assembly o-rings
5	150026400	By-pass valve o-ring
6	150026410	M27x2 plug with seal
7	150026420	Plug seal M27x2

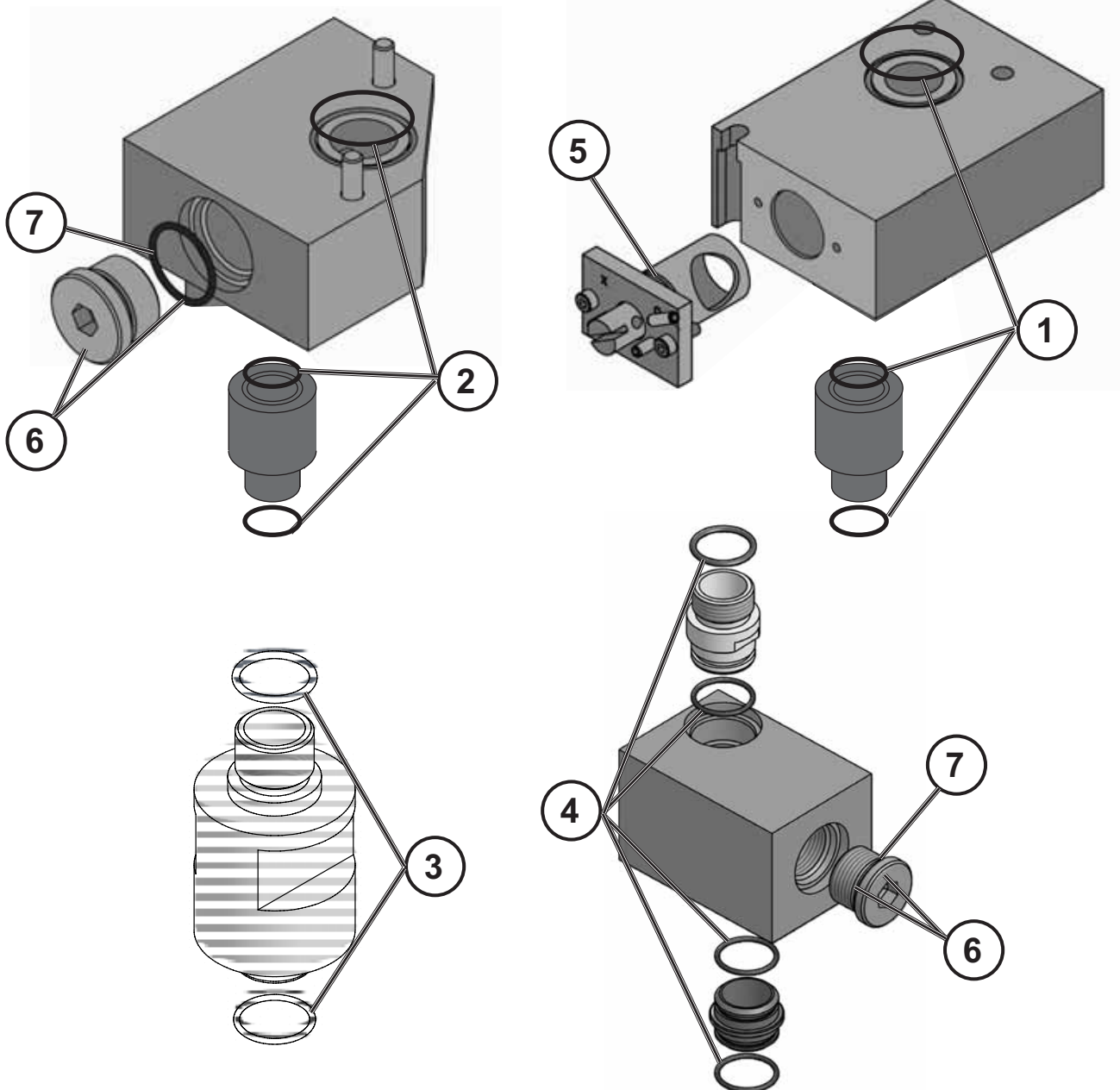

D. MOTOR-PUMP GROUP

N°	Ref.	Description
1	150025960	Single gear pump 1 cc/rev
1	150025930	Single gear pump 4 cc/rev
1	150025970	Single gear pump 8 cc/rev
2	150025980	Double gear pump 0.6x2 cc/rev
2	150025990	Double gear pump 1.2x2 cc/rev
2	150026000	Double gear pump 2.4x2 cc/rev
2	150026010	Double gear pump 4.8x2 cc/rev
3	150026430	Single pump seat o-rings
4	150026450	Double pump seat o-rings
5		Double pump-distributor plate seat o-rings
6	150026460	Single pump motor coupling
7	150026470	Double pump motor coupling
8	150026480	0.25kW geared motor with booster fan

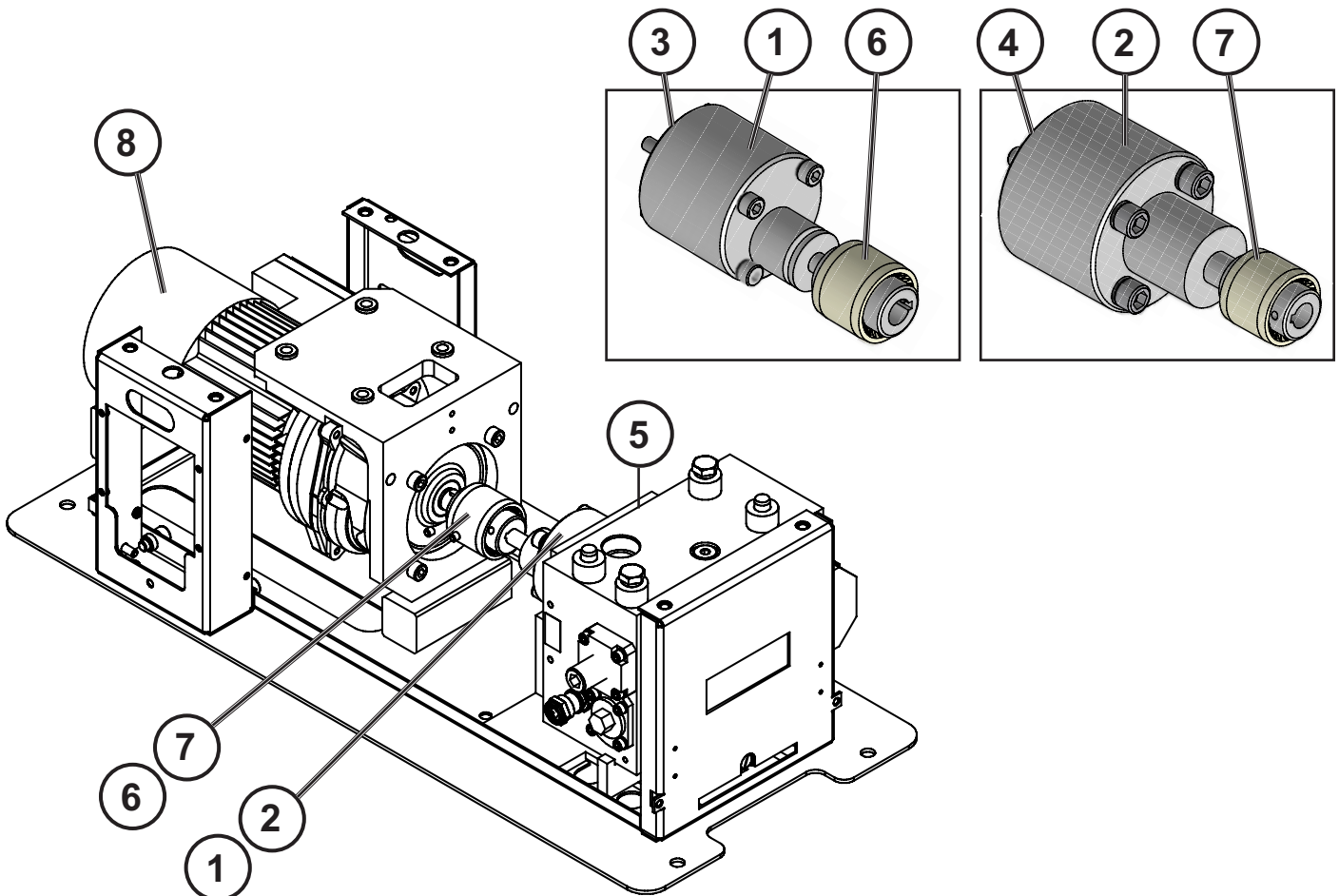

E. CHASSIS GROUP

N°	Ref.	Description
1	150026760	Control board door housing micron
2	150026800	Power board door housing micron
3	150026600	Front movable housing micron4
4	150026920	Front movable housing micron8
5	150027120	Rear fixed housing micron
6	150026640	Rear movable housing micron4
7	150026960	Rear movable housing micron8
8	150026680	Right side movable housing micron4
9	150027000	Right movable housing micron8
10	150026720	Lid assembly micron4
11	150027040	Lid assembly micron8
12	150026880	Cover housing micron4
13	150027080	Cover housing micron8
14	150027750	Front movable housing micron16
15	150027810	Rear movable housing micron16
16	150027780	Right side movable housing micron16
17	150027840	Lid housing micron16
18	150027870	Lid assembly micron16
19	150027900	Cover housing micron16
20	150028300	Tank left side fixed housing micron16

Dark gray color references. Ask for other colors

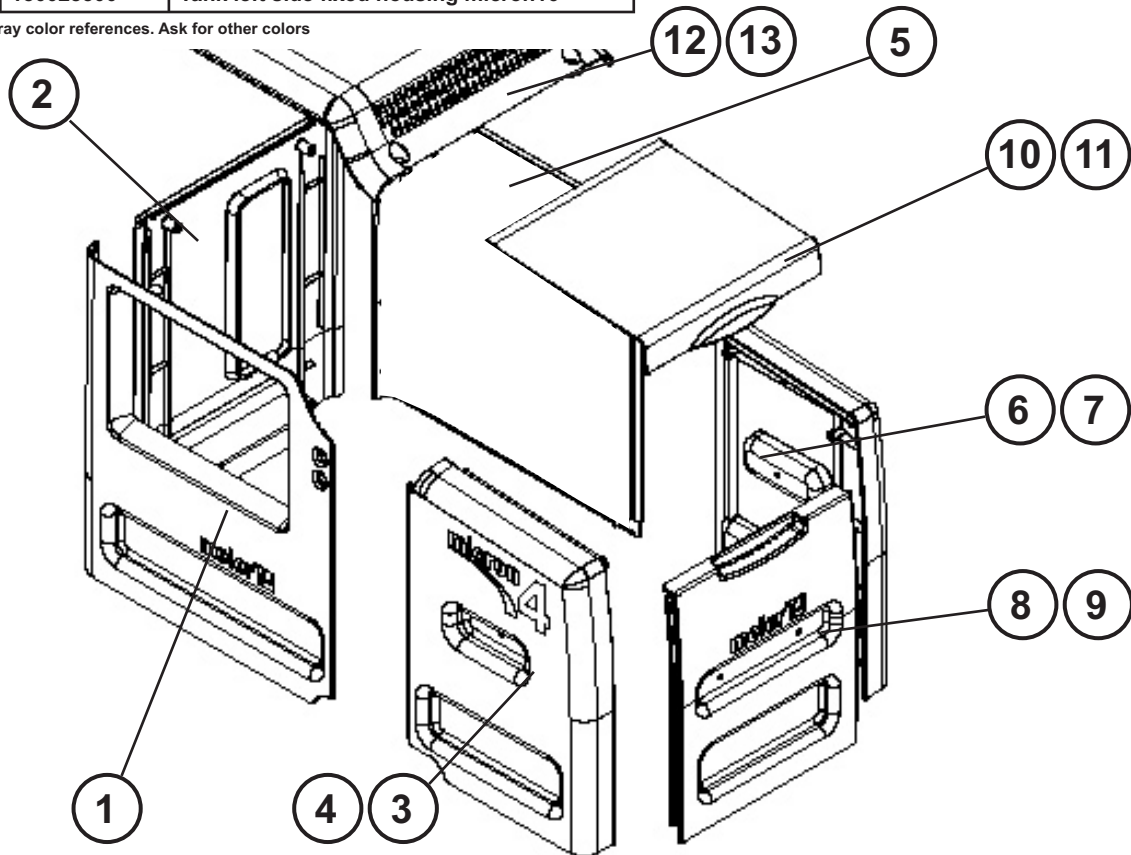
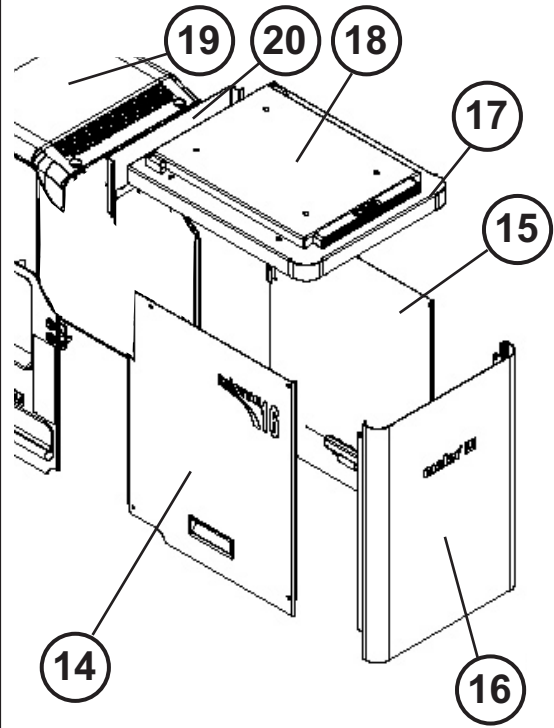

F. ELECTRICAL CABINET

N°	Ref.	Description
1	150024720	Control board micron
2	150024700	Power board micron 2 outlets
2	150024690	Power board micron 6 outlets
3	150024710	Sensor board Pt100/Ni120 micron
4	150090420	2-contact 220V AC relay
5	150090430	2-contact 24V DC relay
6	150090500	Motor inverter 230V AC 0.35kW
7	10110070	DC power supply 220V AC/24V DC 15W
8	10000445	Air drying system timer
9	150112570	Fuse 16A 10x38 ultra fast
10	150112410	Fuse 6,3A 5x20 ultra fast
	150112560	Fuse 6,3A 6x32 ultra fast
11	150024730	Control to power board ribbon cable assembly
12	150024740	Control to sensor board cable assembly
13	150024900	Power board to DC power supply cable

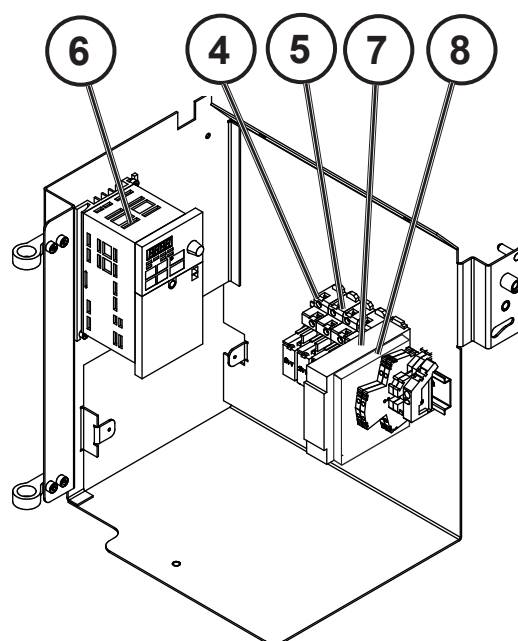
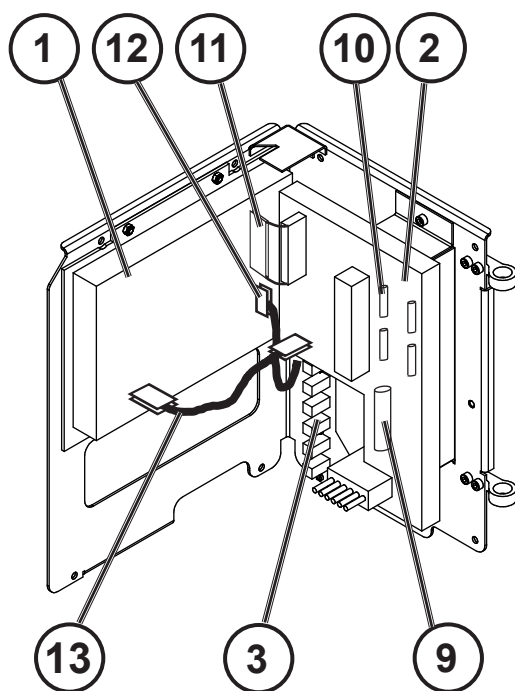

G. AUXILIARY ELECTRICAL COMPONENTS

N°	Ref.	Description
1	150090450	Motor speed display
2	150090460	Potentiometer
3	150090470	Potentiometer handle
4	150090480	Three-position switch
5	16010003	8 pin female connector (base housing)
6	150020720	12 pin female connector (base housing)
7	10140040	Cable gland Pg13
8	150021590	Cable gland Pg9
9	150021600	Main switch
10		Two-position switch

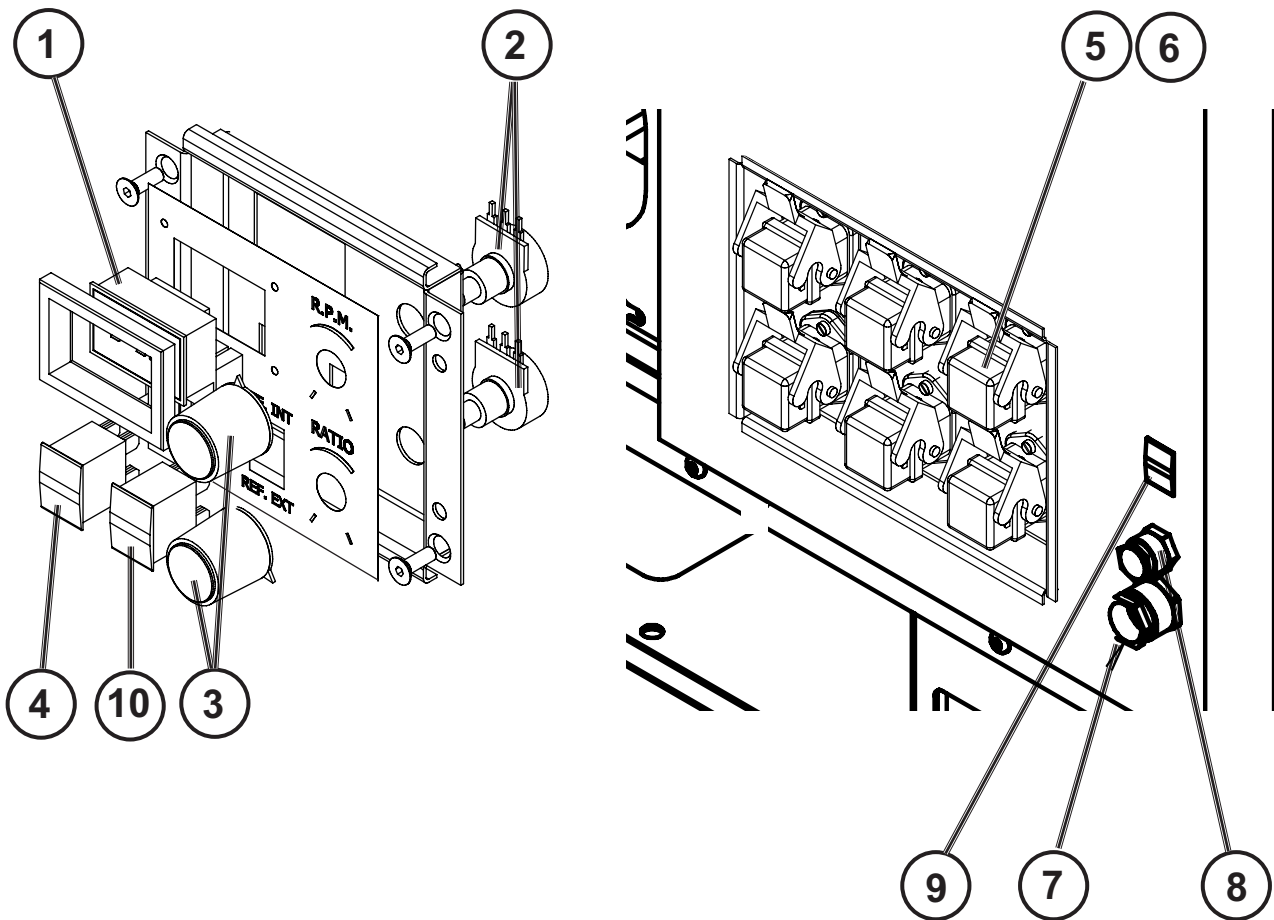

H. AIR DRYER GROUP (OPTIONAL)

N°	Ref.	Description
1	21010010	24V DC by-pass solenoid valve
2	10110030	'meler' pressure gauge
3	10110031	Pressure regulator
4	10110064	90° 1/8" Ø6 fitting
5	10110065	1/8" male-male adapter
6	10110066	Reinforced PTFE Ø4-Ø6 pipe
7	10140079	Air dryer cartridge
8	10140080	1st stage filter cartridge
9	10140081	2nd stage filter cartridge
	10110067	Ø6 gas connector for cover assembly

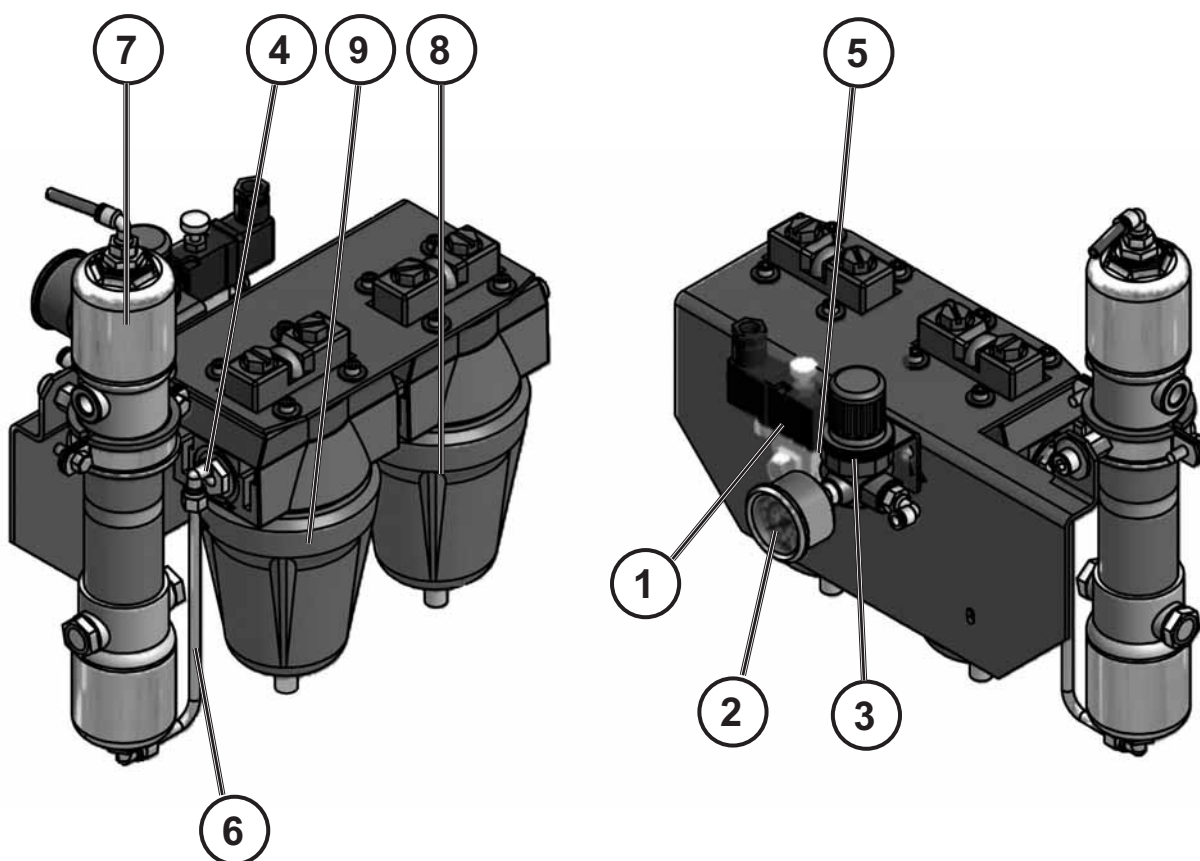



This page is intentionally left blank.

Instructions manual appendix

ADHESIVE MELTER MICRON³²

Gear



meler 

MA-5055-E 250612



Published by:

meler Aplicadores de Hot-melt S.A.
P.I. Los Agustinos, calle G, nave D-43
E - 31160 ORCOYEN Navarra (Spain)

Phone.: + 34 948 351 110
Fax: + 34 948 351 130
e-mail: info@meler.es
web site: www.meler.eu

Edition June 2012
© Copyright by meler

All rights reserved. Its reproduction, diffusion or use by electronic or other means of all or any part of this document without the express authorization of its owner is strictly prohibited.

The specifications and information contained in this manual may be modified without prior notice.

TABLE OF CONTENTS

A1. SAFETY GUIDELINES	A-1
<i>General</i>	A-1
A2. INTRODUCTION	A-3
<i>Main components</i>	A-3
A3. INSTALLATION	A-5
<i>Installation requirements</i>	A-5
Free space	A-5
<i>Electrical power connection</i>	A-6
Starting up the motor	A-7
Motor speed set point reference	A-7
A4. MELTER OPERATION	A-9
<i>Use of the air-tight lid</i>	A-10
Description	A-10
Injection cycle	A-10
Opening and closing the air-tight lid	A-11
A5. MAINTENANCE	A-13
<i>Equipment cleaning</i>	A-13
A6. TECHNICAL CHARACTERISTICS	A-15
<i>General</i>	A-15
<i>Dimensions</i>	A-16
<i>Accessories</i>	A-17
Pneumatic by-pass valve pressure control system	A-17
Level control system	A-17
Air drying system for PUR adhesives	A-17
Automatic tank filling system	A-17
A7. ELECTRICAL DRAWINGS	A-19
<i>Components list version Pt-100</i>	A-19
Version with a single pump installed	A-19
Version with two pumps installed	A-20
<i>Components list version Ni-120</i>	A-21

Version with a single pump installed	A-21
Version with two pumps installed	A-23
A8. PNEUMATIC DIAGRAM	A-25
<i>Components list</i>	A-25
A9. SPARE PARTS LIST	A-27
<i>General</i>	A-27
<i>Air-tight lid</i>	A-28

A1. SAFETY GUIDELINES

General

This appendix belongs to 32 liters version but its operation and working process are identical to the other versions of 'micron gear' series (see chapter '1. Safety guidelines' in this manual).

The information contained in this section applies not only to everyday machine operation, but also to any procedure carried out on it, whether for preventive maintenance or in the case of repairs and the replacement of worn out parts.

It is very important to observe the safety warnings in this manual at all times. Failure to do so may result in personal injury and/or damage to the machine or the rest of the installation.

Before beginning work on the machine, read this manual carefully, and in case of any doubt, contact our Technical Service Center. We are available for any clarification that you might need.

Keep manuals in perfect condition and within reach of personnel that use the machine and perform maintenance on it.

Also provide necessary safety material: appropriate clothing, footwear, gloves and safety glasses.

In all cases, observe local regulations regarding risk prevention and safety.

This page is intentionally left blank.

A2. INTRODUCTION

In this manual you will find information about the installation, use and maintenance of the hot-melt adhesive melter/applier in 'meler's micron' gear series.

The 'micron gear' series includes the 4, 8, 16 and 32 liter range of hot-melt adhesive melters/appliers.

This appendix belongs to 32 liters version but its operation and working process are identical to the other versions of 'micron gear' series (see chapter '2. Introduction' in this manual).

Main components



1. Front control card
2. Access door to the electronic section and connections
3. Tank access cover
4. Air pressure gauge
5. By-pass valve pressure regulator (optional system)
6. Motor control panel
7. Hose output distributor (up to 2 hydraulic connections per motor-pump assembly)
8. Hose-gun electrical connections
9. Main switch and electrical connection
10. Optional air drying system for PUR adhesives
11. Mechanical by-pass valve pressure control

This page is intentionally left blank.

A3. INSTALLATION



Warning: The melters/applicators are equipment with current technology and with certain foreseeable risks. Therefore, only allow qualified personnel with sufficient training and experience to use, install or repair this equipment.

Installation requirements

Before installing 'micron gear' series melter/applicator equipment, we must make sure that the space assigned to it permits installing, connecting and using the entire system. Similarly, we must check to see that the electrical and pneumatic supplies meet the necessary requirements of the melter/applicator equipment being installed.

This appendix belongs to 32 liters version but its operation and working process are identical to the other versions of 'micron gear' series (see chapter '3. Installation' in this manual).

Free space

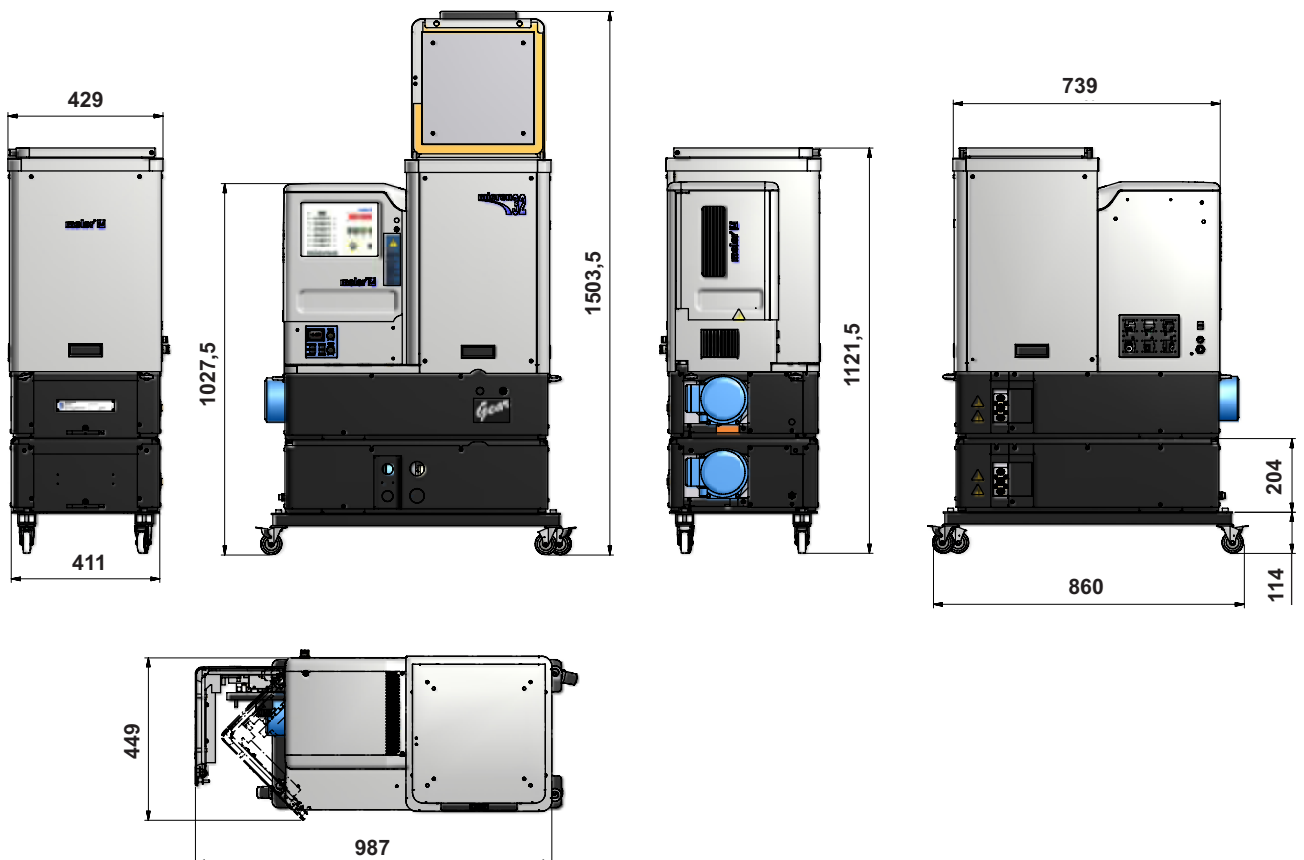

Electrical power connection

'micron gear' series melters/applifiers are designed to be connected to the electrical power supply in three possible ways, depending on their power consumption:

- 1-phase 230 VAC
- 3-phase 230 VAC without neutral
- 3-phase 400 VAC with neutral

UNIT	No. OUTPUTS	1 PHASE		3 PHASES			
		230VAC		230 VAC Δ		400 VAC Y	
		1 PUMP	2 PUMPS	1 PUMP	2 PUMPS	1 PUMP	2 PUMPS
micron32	2	39.5 A	43.1 A	31.2 A	29.8 A	27.0 A	21.8 A
	4	49.8 A	53.5 A	34.9 A	35.1 A	27.0 A	21.8 A
	6	60.3 A	-	37.7 A	-	27.0 A	-

A good ground connection is required in all cases.

Consumption figures, according to melter/applifier and output configuration, are included in the table.

Warning: Risk of electrical shock. Carelessness may cause injury or death.



Install the electrical wall bushing Pg 13.5 in the area reserved for them, fastening them to the plate with the appropriate nut.

Open the electric cabinet door as far as possible. Thread the power cord (Ø6-12 mm) through the electrical wall bushing Pg 13.5 and fasten it to the inside anchor, making sure that the cord reaches the power card connector at the position where it will be installed.

Connect each wire in the power cord to its corresponding place on the power intake connector on the power card.

Connect the two motor control power lines to the corresponding terminals, as shown in the figure.





Starting up the motor

1. If only this signal is going to be wired, use a two-wire 0.5 mm² section cable.

Install a Pg9 electrical wall bushing in the plate at the base of the equipment, next to the electrical power intake.



2. Open the door to the electrical cabinet as far as possible. Run the signal cable (Ø4-8 mm) through the Pg9 bushing and attach it to the inside anchor, making sure that the cable reaches the terminals on the inside, next to the motor variator.

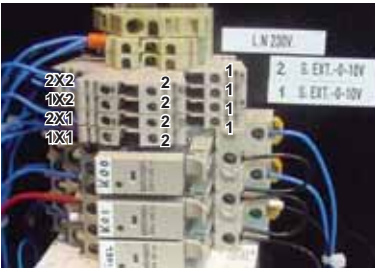

3. Connect the two wires from the start-up signal to the terminal X1, on the bottom. This is a double terminal, which makes it necessary to connect each wire in one of the two holes in the terminal. Since this contact is not under voltage, there is no connection polarity.

4. Make sure that the cables are firmly attached by the terminal screws.



5. For the signal to work, the switch on the control panel must be in the 'AUTO' position.

Motor speed set point reference

1. If only this signal is going to be wired, use a two-wire 0.5 mm² section cable.

Install a Pg9 electrical wall bushing in the plate at the base of the equipment, next to the electrical power intake.



2. Open the door to the electrical cabinet as far as possible. Run the signal cable (Ø4-8 mm) through the Pg9 bushing and attach it to the inside anchor, making sure that the cable reaches the terminals on the inside, next to the motor variator.

3. Connect the two wires from the motor speed set point to the terminal X2, on the bottom. This is a double terminal, which makes it necessary to connect each wire in one of the two holes in the terminal. The positive signal wire must be connected to point 1 of the terminal (inside), while the negative wire must be connected to point 2 (outside).
4. Make sure that the cables are firmly attached by the terminal screws.
5. For the signal to work, the switches on the control panel must be in the 'AUTO' and 'EXT' positions.

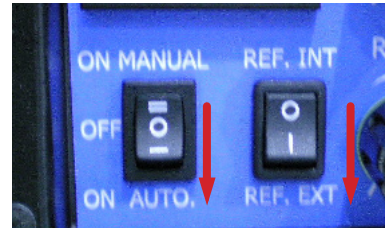
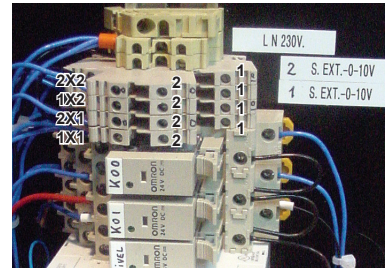

A4. MELTER OPERATION

In this section we will introduce the method for using the melter/ applicator. Although its operation is very simple, it should not be used by untrained personnel.



Warning: Improper use may cause damage to the machine or injury and even death to the person using it.

This appendix belongs to 32 liters version but its operation and working process are identical to the other versions of 'micron gear' series (see chapter '4. Melter operation' in this manual).



Use of the air-tight lid

Description

Optionally, 'micron32 gear' can assemble an air-tight lid for the tank. This option is suitable when the unit has to be used with P.U.R. adhesives. As manual shows in previous chapters P.U.R. adhesives need a completely dry environment before they are applied, otherwise, due to humidity of the air around them, they react in a premature curing.

Dry ambient is done by means of a dry air system installed in the unit with a dry grade of the air up to 99.98%. Thus it guarantees adhesive conservation without premature curing in the unit of the application system.

The dry air system is based on a pressure regulator set at 0.4 bar (with a maximum pressure safety valve), a second pressure regulator set to 0.2 bar for applying the air into the tank through an intake solenoid valve, another solenoid valve to discharge the air inside the tank and a programmable relay to control the system.

For a safety procedure it assembles an inductive sensor (marked with an arrow in the drawing) to control if the first lid is open or closed. When this lid is opened or when the air power supply is shut off, the pressure of the system is released. Electrical connections can be found in the 'Electrical drawings' chapter.

Injection cycle

The injection cycle is done by the programmable relay with two different timers: for the injection time and the pause time between two injections. Set values from factory are 10 s for injection time and 5 min for the pause time.

1. Shows the time in seconds for the set injection time.
2. Shows the time in seconds for the pause time.
3. Line down selection key.
4. Line up selection key.
5. Decreases the time value selected in 'T ON' or 'T OFF'.
6. Increases the time value selected in 'T ON' or 'T OFF'.

When the adhesive block has been charged and both lids are completely closed, intake and exhaust solenoid valves are opened so a flow of air is coming in and out during the time selected in 'T ON'. After that exhaust valve is closed while intake valve remains

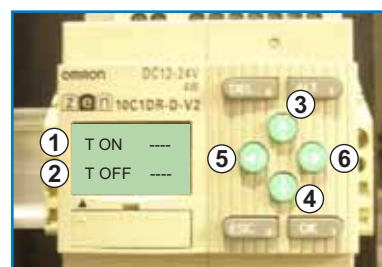

opened for the same time (T ON). Then both valves remain closed while the timer counts set value of 'T OFF' and starts a new cycle time of injection. The system stops if you open the lid or switch off the power supply.

Opening and closing the air-tight lid



Warning: Use appropriate protective equipment for high temperatures.

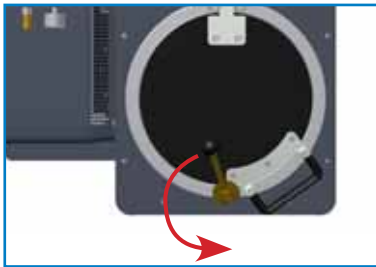

To open the lid you must follow the next steps. Open the cover lid and turn left the lever to the position shown in the picture. Take the handle and lift up the second lid until the hinge is blocked.

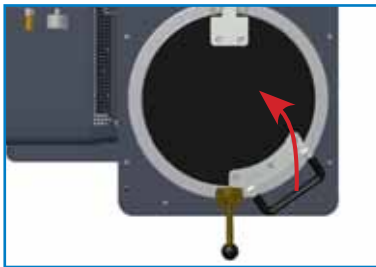

To close the lids, release the blocking pin of the hinge, take the handle and close the lid, pushing softly and turning the lever right to fix it. Then closed the cover lid.

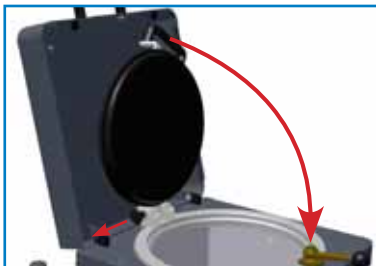

This page is intentionally left blank.

A5. MAINTENANCE



Warning: The melter/appliator equipment is equipped with current technology, but has certain foreseeable risks. Therefore, only allow qualified personnel with enough training and experience to operate install or repair this equipment.

This appendix belongs to 32 liters version but its operation and working process are identical to the other versions of 'micron gear' series (see chapter '5. Maintenance' in this manual).

Equipment cleaning

To continue to take advantage of the melter/appliator's benefits and to ensure the perfect mobility of its components, it is necessary to keep all its parts clean, especially the ventilation grate on the upper part of the machine.



Warning: Risk of electric shock. Carelessness may result in injury or death. Clean the exterior using a cloth moistened with water. Do not use flammable liquids or solvents.

External cleaning:

Use cleaning products compatible with polyamide materials.

Apply the cleaning product with a soft cloth.

Do not use sharp tools or scrapers with sharp edges.

Removing and changing exterior panels:

1. Disconnect the melter/appliator equipment.
2. Disconnect the compressed air from the equipment intake.
3. Remove the screws fastening the various side panels .
4. Remove each panel sliding it in the direction shown in the figures.



This page is intentionally left blank.

A6. TECHNICAL CHARACTERISTICS

General

Tank capacity		32 liters
Pump rate	single pump	6, 24 or 48 kg/h (*)
	double pump (per output)	3.6, 7.2, 14.4 or 28,8 kg/h (*)
Melt rate		30 kg/h (*)
Electrical outputs		2, 4 or 6 with one pump 2 or 4 with two pumps
Hydraulic outputs		2 per pump
Temperature range	(optional)	40 to 200°C (100 to 392°F) 40 to 230°C (100 to 450°F)
Temperature control		RTD (±0,5°C/±1°F) Pt-100 or Ni-120
Max. working pressure (at 6 bar in pneumatic option)		90 bar (1.305 psi)
Max. power supply (at 230 VAC)	with single pump	8.750 W (2 outputs) 11.150 W (4 outputs) 13.550 W (6 outputs)
	with double pump	9.050 W (2 outputs) 11.450 W (4 outputs) 13.850 W (6 outputs)
External functions		Temperatures ok output Low level signal (optional) Standby input External outlet inhibitor Motor start input Motor speed control input
Electrical requirements		230V 1~ 50/60 Hz + N + PE 230V 3~ 50/60 Hz + PE 400V 3~ 50/60 Hz + N + PE
Workplace temperature		0 to 40°C
Dimensions (LxWxH)	with one pump	860x429x917.5
	with two pumps	860x429x1121.5

(*) Under standard conditions

Dimensions

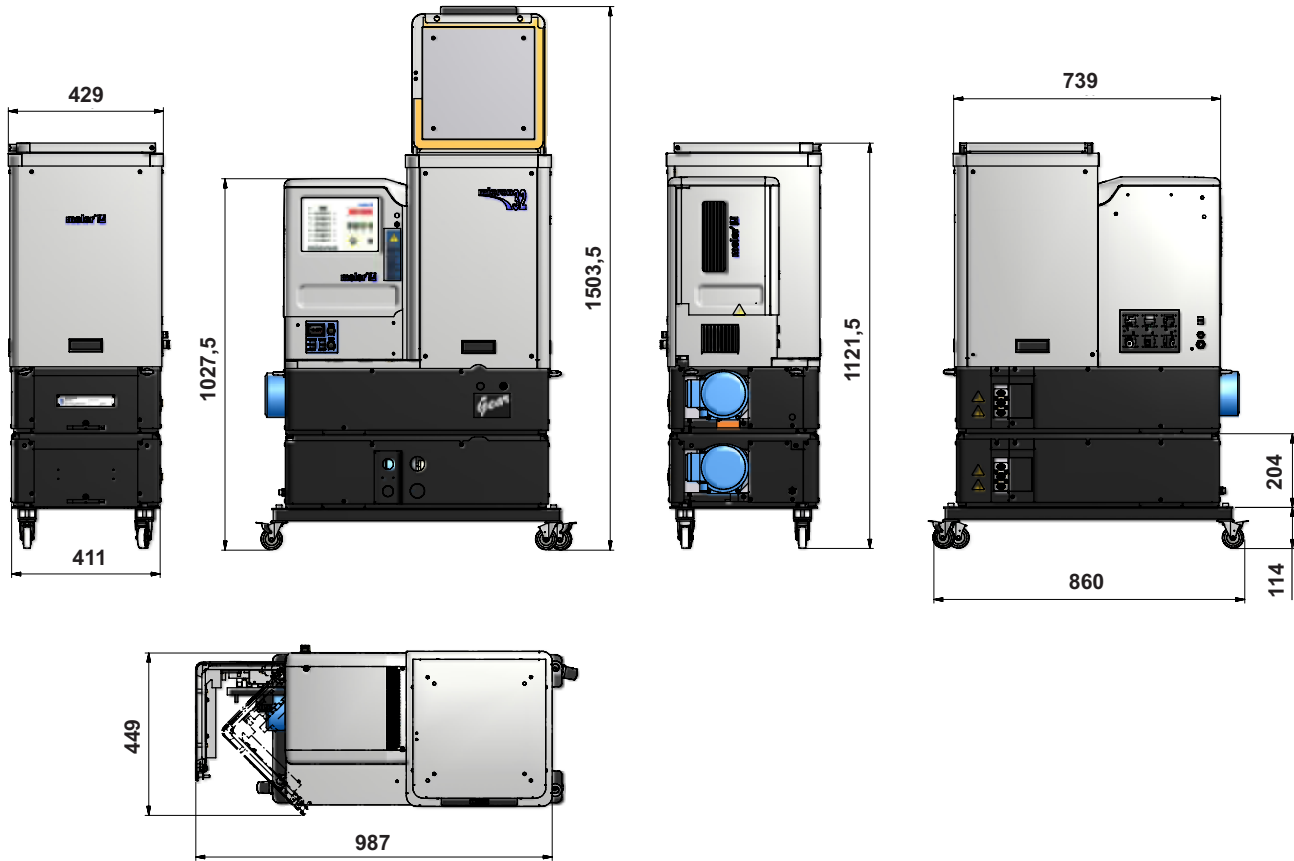

Accessories

Pneumatic by-pass valve pressure control system

The equipment's by-pass valve provides an important safety feature, as it limits the maximum pressure in the system, especially during continuous pumping periods with closed applicator guns.

This valve may be manually adjusted by a threaded spindle. It is possible to add a pneumatic adjustment system, which uses a pressure regulator and a pressure gauge display with a 1 to 15 ratio to the hydraulic pressure.

Level control system

To control the hot-melt level from the control card display screen or from the main machine, using the NO (normally open) contact, with no voltage.

Air drying system for PUR adhesives

Polyurethane-based reactive adhesives, known as P.U.R. (reactive polyurethanes), require a completely dry environment before they can be applied, since when they come in contact with atmospheric humidity, they reticulate, hardening quickly.

The 'micron gear' melting equipment ensures a dry environment thanks to the addition of an air-drying system to these models, which provides a level of dehumidification above 99.98%. This guarantees that the adhesive is preserved without premature reticulations inside the applicator unit.

Automatic tank filling system

'meler' pellet loaders ensure a continuous level of adhesive inside the tanks of the melting units, eliminating the need for manual loading by the user.

Each time the tank sensor detects a low level of adhesive, it sends a signal to the suction system, which transfers a load of pellets to the melting tank from the adhesive container (or directly from the bag it comes in).

This page is intentionally left blank.

A7. ELECTRICAL DRAWINGS

Components list version Pt-100

Version with a single pump installed

-2A1	Power card (2 or 6 outputs)
-2B3	Level sensor
-1B6	240°C safety thermostat
-2K3	2-contact 220V AC relay motor start enabled
-1R5	Tank resistance 1000W 230V
-1R5.1	Tank resistance 1000W 230V
-1R5.2	Tank resistance 1000W 230V
-1R8	Tank resistance 1000W 230V
-1R8.1	Tank resistance 1000W 230V
-1R8.2	Tank resistance 1000W 230V
-2R4	Distributor resistance 300W (single or double pump)
-2R4.1	Distributor resistance 300W (single or double pump)
-2R4.2	Distributor resistance 300W (single or double pump)
-2R5	Distributor resistance 300W (double pump)
-1F6	2-pole thermal-magnetic circuit breaker 16A
-1V5/1V7	Tank solid state relay
-2S2	ON-OFF switch
-3A3	Sensor card
-3B2	Pt-100 tank temperature sensor
-3B2.1	Pt-100 distributor temperature sensor
-3CN1	8-pole channel 1 connector
-3CN3.2	8-pole channel 2 connector
-3CN4.2	8-pole channel 3 connector
-3CN5.3	8-pole channel 4 connector
-3CN6.1	8-pole channel 5 connector
-3CN7	8-pole channel 6 connector
-4A1	Control card
-4K7	2-contact 24V DC relay for control circuit power
-5A5	Motor inverter 230V AC 0.25kW
-5K2	2-contact 24V DC relay for fan start
-5K2.1	2-contact 24V DC relay for set point reference
-5M7	0.25kW geared motor with booster fan
-5P3	Motor revolutions display
-5R3	Maximum speed motor 'RATIO' potentiometer
-5R4	Motor 'R.P.M.' speed regulation potentiometer
-5S2	MANUAL/OFF/AUTO switch
-5S2.1	INT/EXT switch
-F01	Tank fuse 16A 500V gG
-F02	Distributor fuse 6A 500V gG
-F03	Low level signal fuse 2A 250V F
-F04	Channel 1 fuse (hose-gun) 6A 250V F
-F05	Channel 1 fuse (hose-gun) 6A 250V F
-F06	Channel 1 fuse (hose-gun) 6A 250V F
-F07	Channel 1 fuse (hose-gun) 6A 250V F
-F08	Channel 1 fuse (hose-gun) 6A 250V F
-F09	Channel 1 fuse (hose-gun) 6A 250V F
-F10	DC Power supply fuse 0.5A 250V T

- X1 Motor start input terminals
- X2 Motor speed set point terminals (0-10V DC)
- X3 Ceramic power block connection to distributor
- X4 Ceramic power block connection to level detector
- X5/X6 Control circuit power input terminals

Optionally:

- 4G6 DC power supply 220V AC/24V DC 15W
- 4T7 Air drying system timer
- 4CN7 Air drying system solenoid valve connector

Version with two pumps installed

- 2A1 Power card (6 outputs)
- 2B3 Level sensor
- 1B6 240°C safety thermostat
- 2K3 2-contact 220V AC relay motor start enabled
- 1R5 Tank resistance 1000W 230V
- 1R5.1 Tank resistance 1000W 230V
- 1R5.2 Tank resistance 1000W 230V
- 1R7 Tank resistance 1000W 230V
- 1R7.1 Tank resistance 1000W 230V
- 1R7.2 Tank resistance 1000W 230V
- 2R4 Distributor1 resistance 300W (single or double pump)
- 2R4.1 Distributor1 resistance 300W (single or double pump)
- 2R5 Distributor1 resistance 300W (single or double pump)
- 2R5.1 Distributor1 resistance 300W (double pump)
- 2R6 Distributor2 resistance 300W (single or double pump)
- 2R7 Distributor2 resistance 300W (single or double pump)
- 2R7.1 Distributor2 resistance 300W (single or double pump)
- 2R8 Distributor2 resistance 300W (double pump)
- 1F6 2-pole thermal-magnetic circuit breaker 16A
- 1V5/1V7 Tank solid state relay
- 2S2 ON-OFF switch
- 3A3 Sensor card
- 3B2 Pt-100 tank temperature sensor
- 3B2.1 Pt-100 tank temperature sensor
- 3B2.2 Pt-100 distributor1 temperature sensor
- 3B3 Pt-100 distributor2 temperature sensor
- 3CN4.2 8-pole channel 3 connector
- 3CN5.3 8-pole channel 4 connector
- 3CN6.1 8-pole channel 5 connector
- 3CN7 8-pole channel 6 connector
- 4A1 Control card
- 4K7 2-contact 24V DC relay for control circuit power
- 5A5 Motor1 inverter 230V AC 0.25kW
- 5K2 2-contact 24V DC relay for fan1 start
- 5K2.1 2-contact 24V DC relay for set point reference1
- 5M7 0.25kW geared motor1 with booster fan

-5P3	Motor1 revolutions display
-5R3	Maximum speed motor1 'RATIO' potentiometer
-5R4	Motor1 'R.P.M.' speed regulation potentiometer
-5S2	MANUAL/OFF/AUTO switch motor1
-5S2.1	INT/EXT switch motor1
-6A5	Motor2 inverter 230V AC 0.25kW
-6K2	2-contact 24V DC relay for fan2 start
-6K2.1	2-contact 24V DC relay for set point reference2
-6M7	0.25kW geared motor2 with booster fan
-6P3	Motor2 revolutions display
-6R3	Maximum speed motor2 'RATIO' potentiometer
-6R4	Motor2 'R.P.M.' speed regulation potentiometer
-6S2	MANUAL/OFF/AUTO switch motor2
-6S2.1	INT/EXT switch motor2
-F01	Tank fuse 16A 500V gG
-F02	
-F03	Low level signal fuse 2A 250V F
-F04	Distributor1 fuse 6A 250V F
-F05	Distributor2 fuse 6A 250V F
-F06	Channel 1 fuse (hose-gun) 6A 250V F
-F07	Channel 2 fuse (hose-gun) 6A 250V F
-F08	Channel 3 fuse (hose-gun) 6A 250V F
-F09	Channel 4 fuse (hose-gun) 6A 250V F
-F10	DC Power supply fuse 0.5A 250V T
-X1(1)	Motor start input terminals
-X2(1)	Motor speed set point terminals (0-10V DC)
-X1(2)	Motor start input terminals
-X2(2)	Motor speed set point terminals (0-10V DC)
-X3	Ceramic power block connection to distributor1
-X4	Ceramic power block connection to level detector
-X5/X6	Control circuit power input terminals
-X7	Ceramic power block connection to distributor2

Optionally:

-4G6	DC power supply 220V AC/24V DC 15W
-4T7	Air drying system timer
-4CN7	Air drying system solenoid valve connector

Components list version Ni-120

Version with a single pump installed

-2A1	Power card (2 or 6 outputs)
-2B3	Level sensor
-1B6	240°C safety thermostat
-2K3	2-contact 220V AC relay motor start enabled
-1R5	Tank resistance 1000W 230V
-1R5.1	Tank resistance 1000W 230V
-1R5.2	Tank resistance 1000W 230V

-1R8	Tank resistance 1000W 230V
-1R8.1	Tank resistance 1000W 230V
-1R8.2	Tank resistance 1000W 230V
-2R4	Distributor resistance 300W (single or double pump)
-2R4.1	Distributor resistance 300W (single or double pump)
-2R4.2	Distributor resistance 300W (single or double pump)
-2R5	Distributor resistance 300W (double pump)
-1F6	2-pole thermal-magnetic circuit breaker 16A
-1V5/1V7	Tank solid state relay
-2S2	ON-OFF switch
-3A3	Sensor card
-3B2	Ni-120 tank temperature sensor
-3B2.1	Ni-120 distributor temperature sensor
-3CN1	12-pole channel 1 connector
-3CN3.2	12-pole channel 2 connector
-3CN4.2	12-pole channel 3 connector
-3CN5.3	12-pole channel 4 connector
-3CN6.1	12-pole channel 5 connector
-3CN7	12-pole channel 6 connector
-4A1	Control card
-4K7	2-contact 24V DC relay for control circuit power
-5A5	Motor inverter 230V AC 0.25kW
-5K2	2-contact 24V DC relay for fan start
-5K2.1	2-contact 24V DC relay for set point reference
-5M7	0.25kW geared motor with booster fan
-5P3	Motor revolutions display
-5R3	Maximum speed motor 'RATIO' potentiometer
-5R4	Motor 'R.P.M.' speed regulation potentiometer
-5S2	MANUAL/OFF/AUTO switch
-5S2.1	INT/EXT switch
-F01	Tank fuse 16A 500V gG
-F02	Distributor fuse 6A 500V gG
-F03	Low level signal fuse 2A 250V F
-F04	Channel 1 fuse (hose-gun) 6A 250V F
-F05	Channel 2 fuse (hose-gun) 6A 250V F
-F06	Channel 3 fuse (hose-gun) 6A 250V F
-F07	Channel 4 fuse (hose-gun) 6A 250V F
-F08	Channel 5 fuse (hose-gun) 6A 250V F
-F09	Channel 6 fuse (hose-gun) 6A 250V F
-F10	DC Power supply fuse 0.5A 250V T
-X1	Motor start input terminals
-X2	Motor speed set point terminals (0-10V DC)
-X3	Ceramic power block connection to distributor
-X4	Ceramic power block connection to level detector
-X5/X6	Control circuit power input terminals

Optionally:

-4G6	DC power supply 220V AC/24V DC 15W
-4T7	Air drying system timer
-4CN7	Air drying system solenoid valve connector

Version with two pumps installed

-2A1	Power card (6 outputs)
-2B3	Level sensor
-1B6	240°C safety thermostat
-2K3	2-contact 220V AC relay motor start enabled
-1R5	Tank resistance 1000W 230V
-1R5.1	Tank resistance 1000W 230V
-1R5.2	Tank resistance 1000W 230V
-1R7	Tank resistance 1000W 230V
-1R7.1	Tank resistance 1000W 230V
-1R7.2	Tank resistance 1000W 230V
-2R4	Distributor1 resistance 300W (single or double pump)
-2R4.1	Distributor1 resistance 300W (single or double pump)
-2R5	Distributor1 resistance 300W (single or double pump)
-2R5.1	Distributor1 resistance 300W (double pump)
-2R6	Distributor2 resistance 300W (single or double pump)
-2R7	Distributor2 resistance 300W (single or double pump)
-2R7.1	Distributor2 resistance 300W (single or double pump)
-2R8	Distributor2 resistance 300W (double pump)
-1F6	2-pole thermal-magnetic circuit breaker 16A
-1V5/1V7	Tank solid state relay
-2S2	ON-OFF switch
-3A3	Sensor card
-3B2	Ni-120 tank temperature sensor
-3B2.1	Ni-120 tank temperature sensor
-3B2.2	Ni-120 distributor temperature sensor
-3B3	Ni-120 distributor temperature sensor
-3CN4.2	12-pole channel 1 connector
-3CN5.3	12-pole channel 2 connector
-3CN6.1	12-pole channel 3 connector
-3CN7	12-pole channel 4 connector
-4A1	Control card
-4K7	2-contact 24V DC relay for control circuit power
-5A5	Motor1 inverter 230V AC 0.25kW
-5K2	2-contact 24V DC relay for fan1 start
-5K2.1	2-contact 24V DC relay for set point reference1
-5M7	0.25kW geared motor1 with booster fan
-5P3	Motor1 revolutions display
-5R3	Maximum speed motor1 'RATIO' potentiometer
-5R4	Motor1 'R.P.M.' speed regulation potentiometer
-5S2	MANUAL/OFF/AUTO switch motor1
-5S2.1	INT/EXT switch motor1
-6A5	Motor2 inverter 230V AC 0.25kW
-6K2	2-contact 24V DC relay for fan2 start
-6K2.1	2-contact 24V DC relay for set point reference2
-6M7	0.25kW geared motor2 with booster fan
-6P3	Motor2 revolutions display
-6R3	Maximum speed motor2 'RATIO' potentiometer
-6R4	Motor2 'R.P.M.' speed regulation potentiometer
-6S2	MANUAL/OFF/AUTO switch motor2

- 6S2.1 INT/EXT switch motor2
- F01 Tank fuse 16A 500V gG
- F02
- F03 Low level signal fuse 2A 250V F
- F04 Distributor1 fuse 6A 250V F
- F05 Distributor2 fuse 6A 250V F
- F06 Channel 1 fuse (hose-gun) 6A 250V F
- F07 Channel 2 fuse (hose-gun) 6A 250V F
- F08 Channel 3 fuse (hose-gun) 6A 250V F
- F09 Channel 4 fuse (hose-gun) 6A 250V F
- F10 DC Power supply fuse 0.5A 250V T
- X1(1) Motor start input terminals
- X2(1) Motor speed set point terminals (0-10V DC)
- X1(2) Motor start input terminals
- X2(2) Motor speed set point terminals (0-10V DC)
- X3 Ceramic power block connection to distributor1
- X4 Ceramic power block connection to level detector
- X5/X6 Control circuit power input terminals
- X7 Ceramic power block connection to distributor2

Optionally:

- 4G6 DC power supply 220V AC/24V DC 15W
- 4T7 Air drying system timer
- 4CN7 Air drying system solenoid valve connector

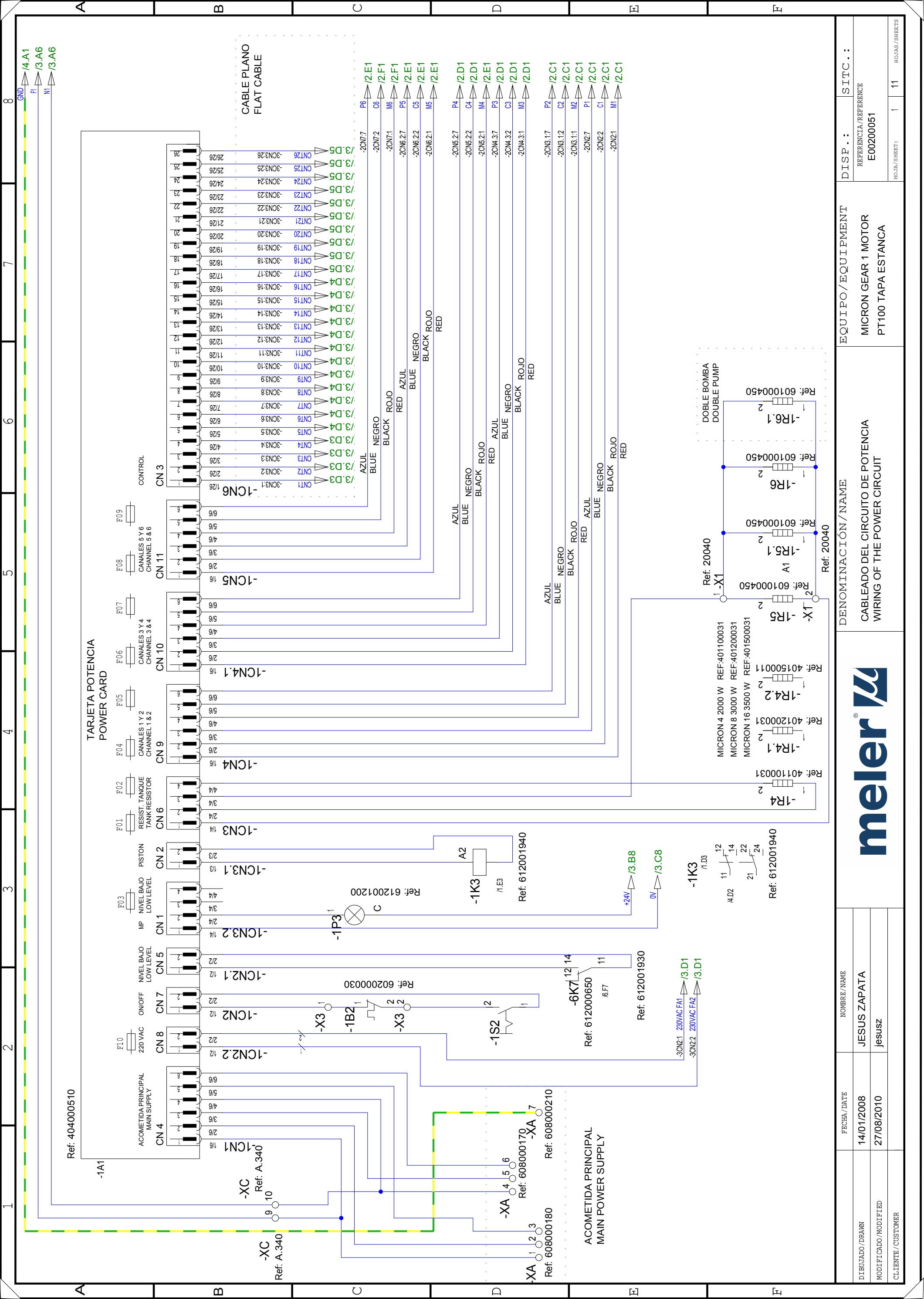

DISP.:	SITC.:
REFERENCIA/REFERENCE	E00200051

EQUIPO/EQUIPMENT	MICRON GEAR 1 MOTOR PT100 TAPA ESTANCA
------------------	---

DENOMINACIÓN/NAME	CABLEADO DEL CIRCUITO DE POTENCIA WIRING OF THE POWER CIRCUIT
-------------------	--



FECHA/DATE	14/01/2008
NOMBRE/NAME	JESUS ZAPATA
DIBUJADO/DRAWN	jesusz
MODIFICADO/MODIFIED	
CLIENTE/CUSTOMER	

HORA/SHEET:	1
HOURS/SHEETS	11

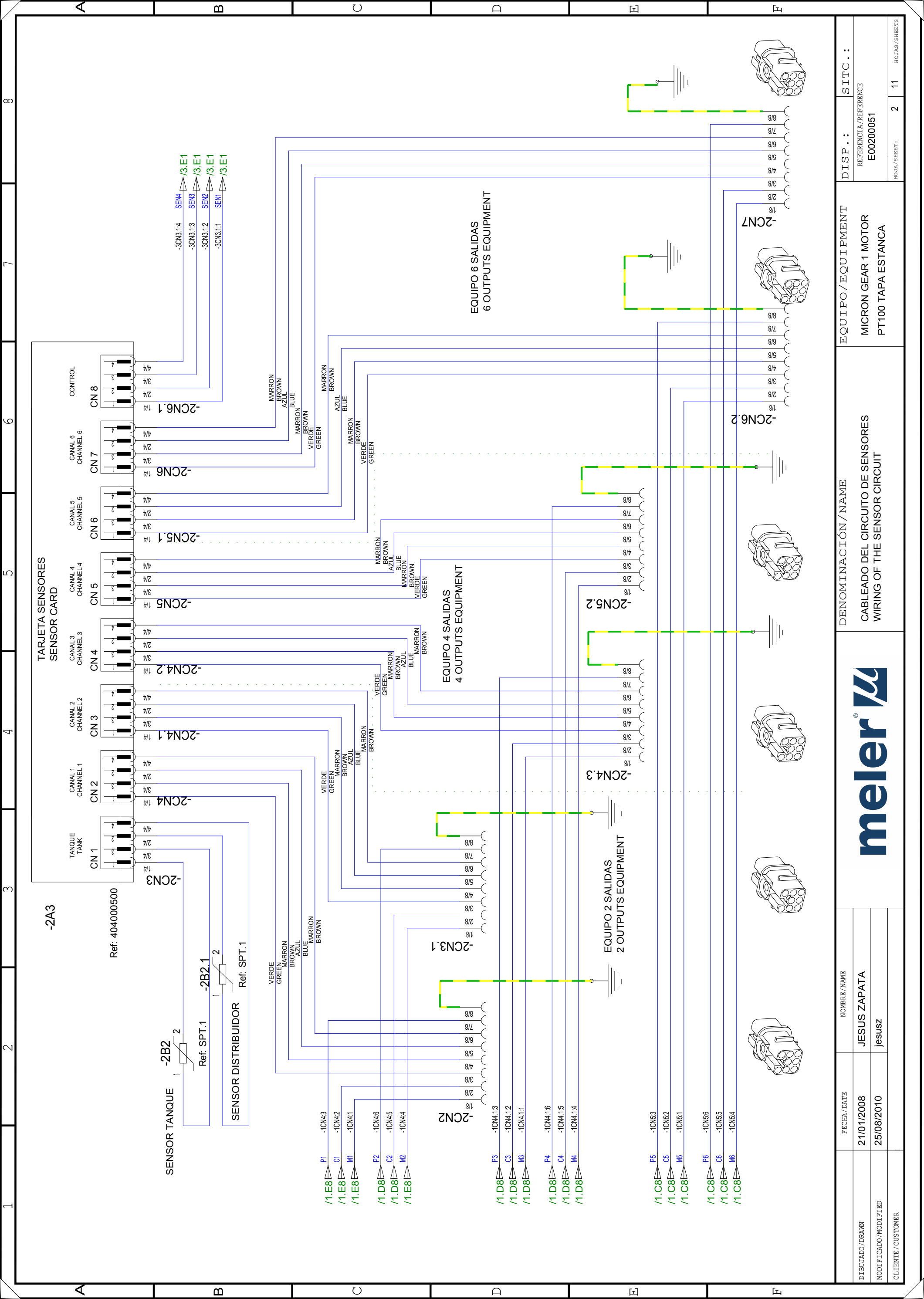

DISP.:	SITC.:
REFERENCIA/REFERENCE	E00200051
HORA/SHEET:	2 11

EQUIPO/EQUIPMENT	MICRON GEAR 1 MOTOR PT100 TAPA ESTANCA
------------------	---

DENOMINACIÓN/NAME	CABLEADO DEL CIRCUITO DE SENSORES WIRING OF THE SENSOR CIRCUIT
-------------------	---

FECHA/DATE	21/01/2008
NOMBRE/NAME	JESUS ZAPATA
DIBUJADO/DRAWN	jesusz
MODIFICADO/MODIFIED	
CLIENTE/CUSTOMER	

meler	
--------------	--

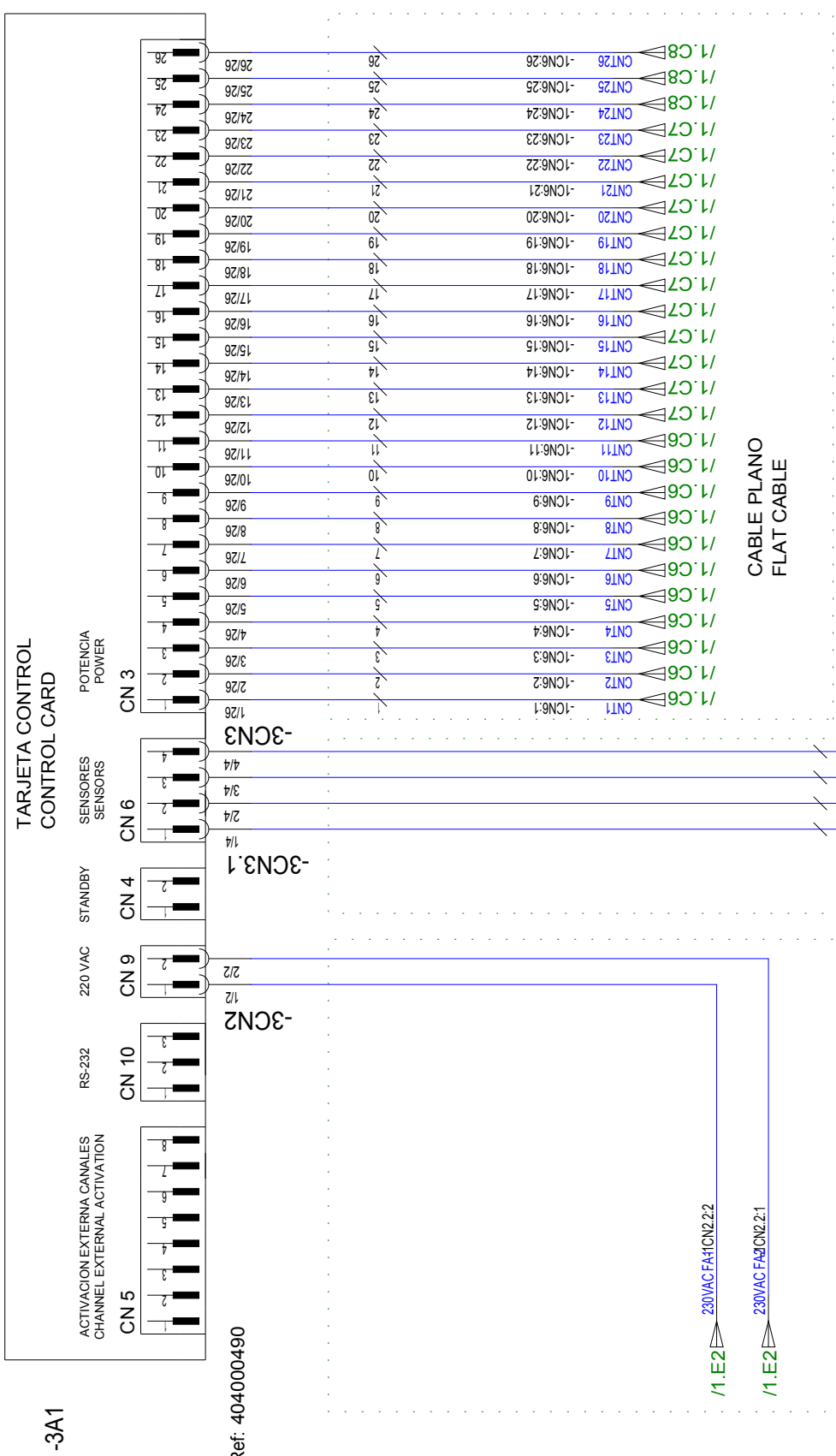
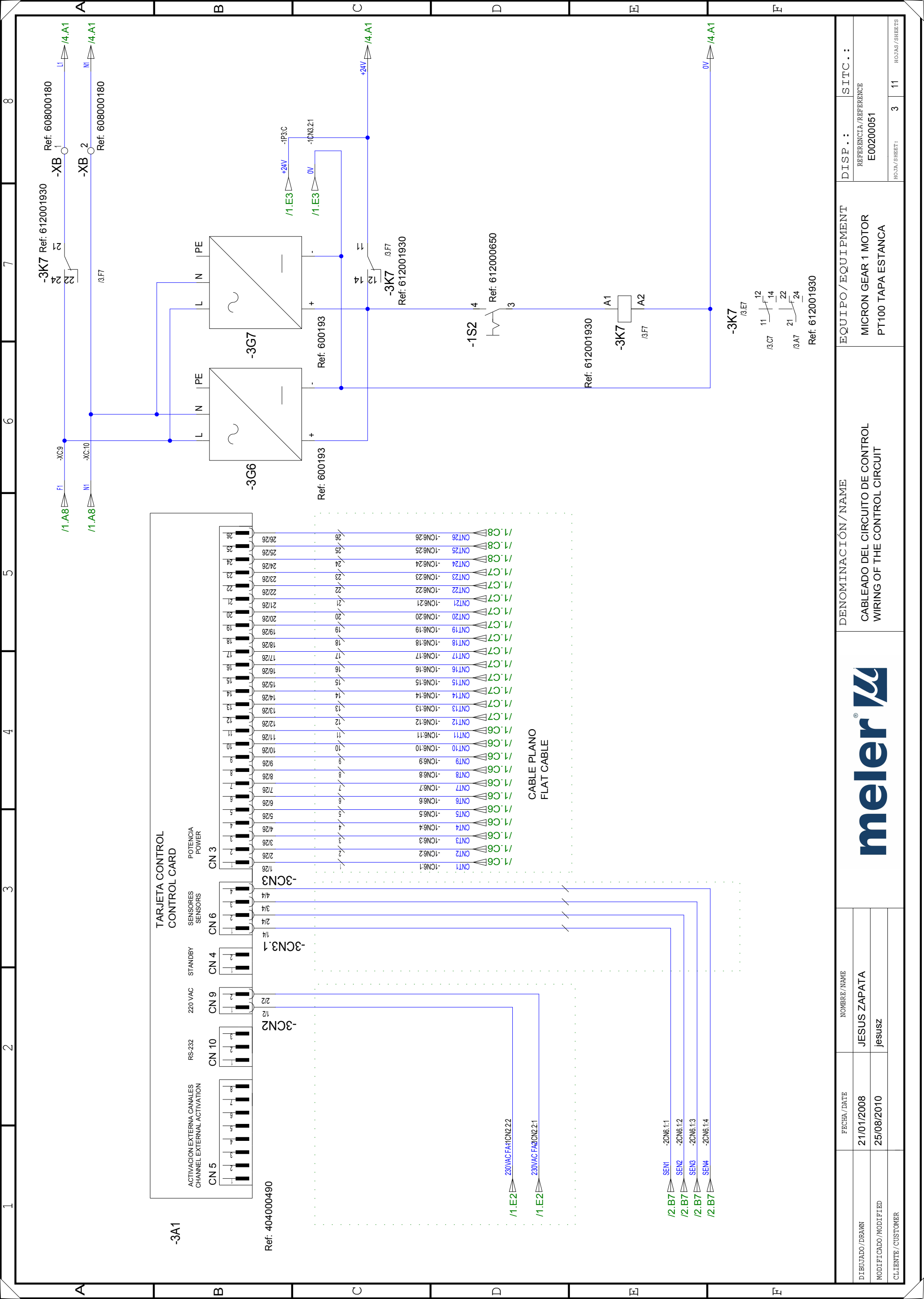

FECHA / DATE	NOMBRE / NAME	EQUIPO / EQUIPMENT	DISP . :	SITC . :
21/01/2008	JESUS ZAPATA	MICRON GEAR 1 MOTOR	REFERENCIA / REFERENCE	E00200051
25/08/2010	jesusz	PT100 TAPA ESTANCA	HORA / SHEET:	3 11
CLIENTE / CUSTOMER				HOURS / SHEETS

DENOMINACIÓN / NAME		CABLEADO DEL CIRCUITO DE CONTROL WIRING OF THE CONTROL CIRCUIT	
meler			

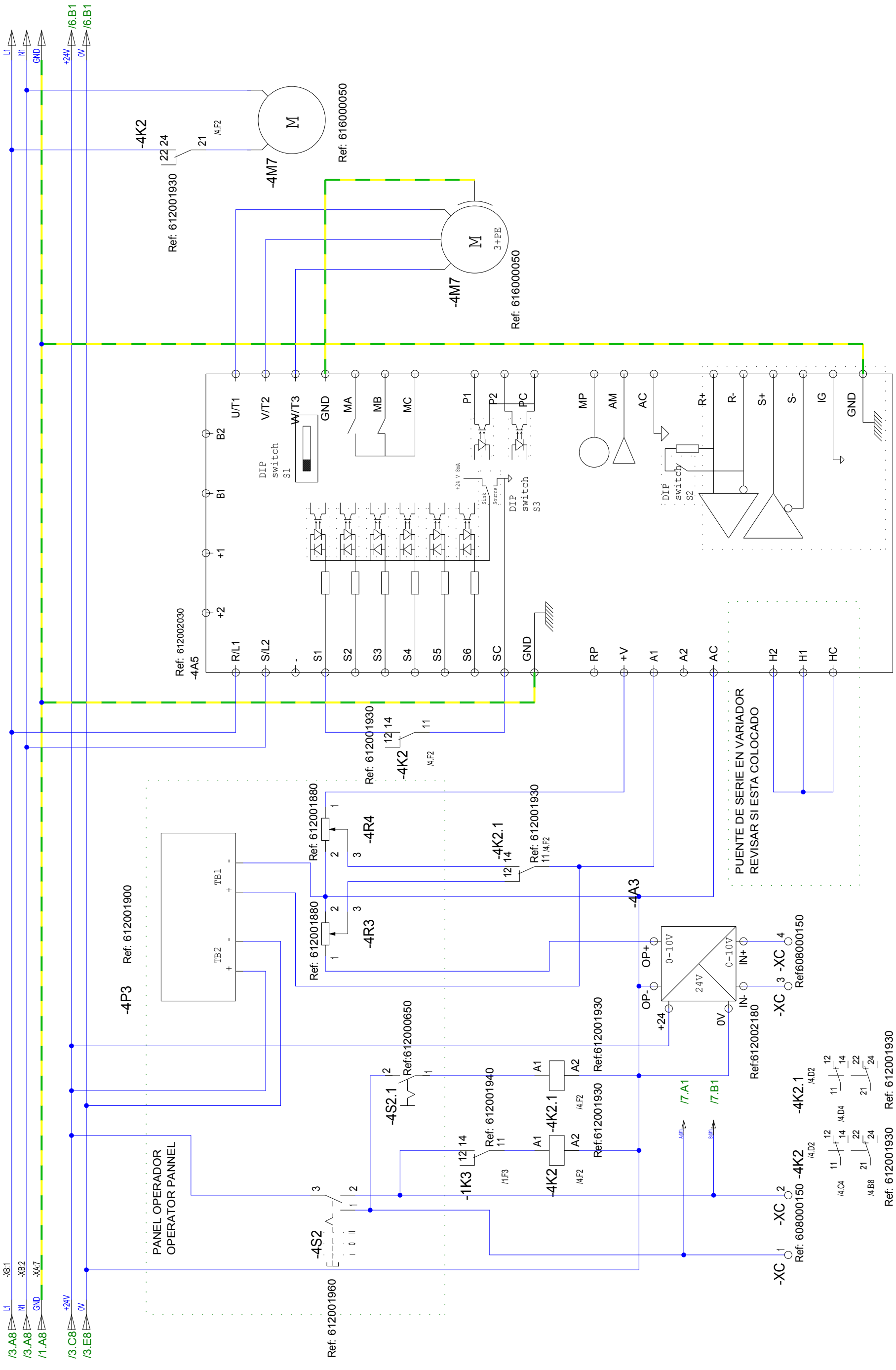

DISP.:	SITC.:
REFERENCIA/REFERENCE	E00200051
HORA/SHEET:	4 / 11

EQUIPO/EQUIPMENT
 MICRON GEAR 1 MOTOR
 PT100 TAPA ESTANCA

DENOMINACIÓN/NAME
 CABLEADO DEL CÍJUTO DE MOTOR M1
 WIRING OF THE MOTOR CIRCUIT M1



FECHA/DATE	NOMBRE/NAME
23/01/2008	JESUS ZAPATA
25/08/2010	jesusz
CLIENTE/CUSTOMER	

PUENTE DE SERIE EN VARIADOR
 REVISAR SI ESTA COLOCADO

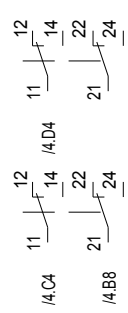

Ref: 612001930 Ref: 612001930

		1			2			3			4			5			6			7			8																										
		<table border="1"> <tr> <td colspan="2">FECHA / DATE</td> <td colspan="4">NOMBRE / NAME</td> </tr> <tr> <td colspan="2">29/01/2008</td> <td colspan="4">JESUS ZAPATA</td> </tr> <tr> <td colspan="2">25/08/2010</td> <td colspan="4">jesusz</td> </tr> <tr> <td colspan="2">CLIENTE / CUSTOMER</td> <td colspan="4"></td> </tr> </table>																								FECHA / DATE		NOMBRE / NAME				29/01/2008		JESUS ZAPATA				25/08/2010		jesusz				CLIENTE / CUSTOMER					
FECHA / DATE		NOMBRE / NAME																																															
29/01/2008		JESUS ZAPATA																																															
25/08/2010		jesusz																																															
CLIENTE / CUSTOMER																																																	
								DENOMINACIÓN / NAME						EQUIPO / EQUIPMENT						DISP. :		SITC. :																											
		RESERVA						MICRON GEAR 1 MOTOR						REFERENCIA / REFERENCE		E00200051																																	
		RESERVE						PT100 TAPA ESTANCA						HORA / SHEET:		5		11																															

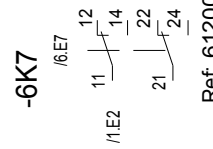
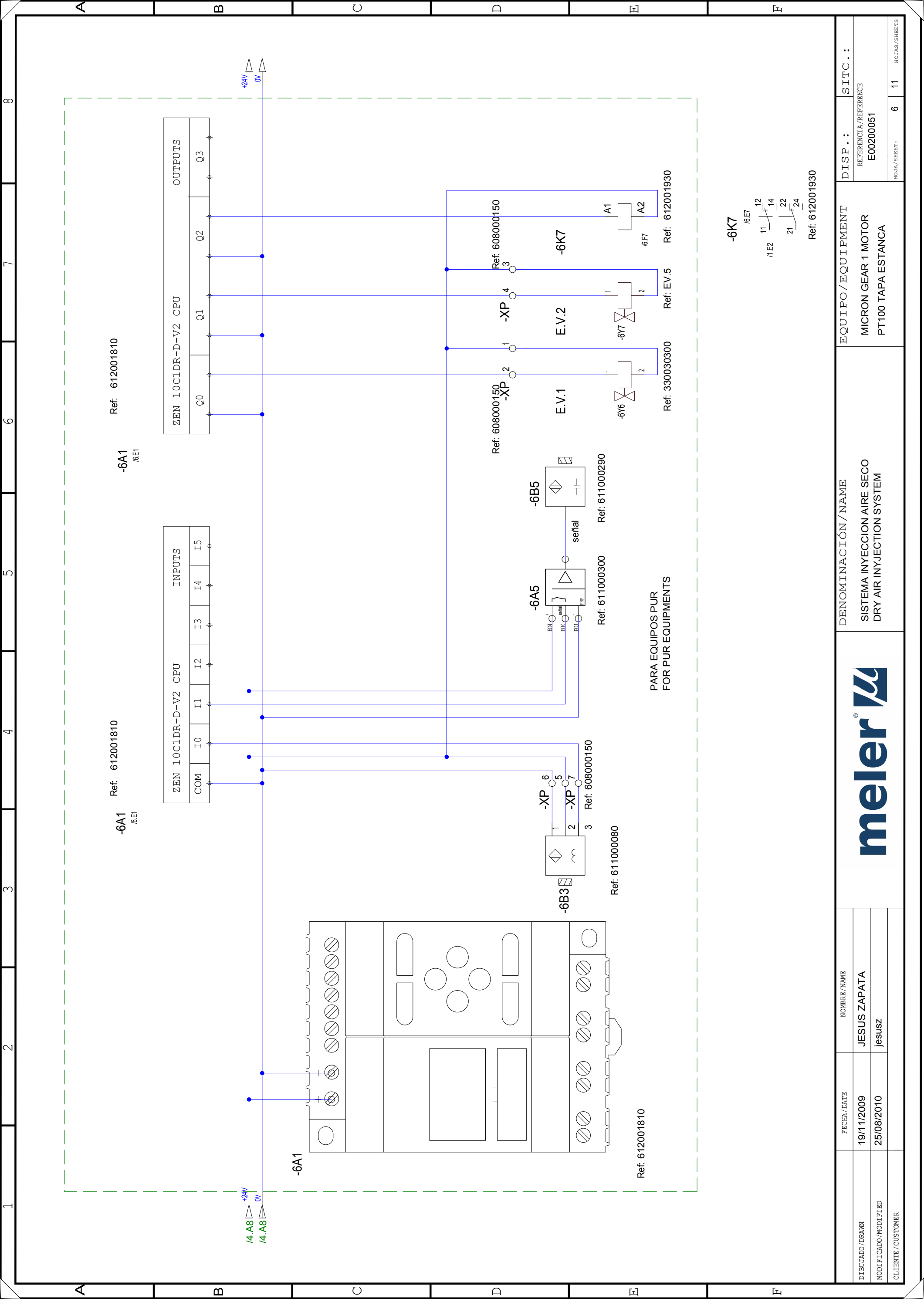

PARA EQUIPOS PUR
FOR PUR EQUIPMENTS

FECHA / DATE	19/11/2009	NOMBRE / NAME	JESUS ZAPATA	EQUIPO / EQUIPMENT	MICRON GEAR 1 MOTOR	DISP. .:	SITC. .:
DIBUJADO / DRAWN					PT100 TAPA ESTANCA	REFERENCIA / REFERENCE	E00200051
MODIFICADO / MODIFIED	25/08/2010	jesusz				HORA / SHEET:	6 11
CLIENTE / CUSTOMER							HOURS / SHEETS



DENOMINACIÓN / NAME
SISTEMA INYECCION AIRE SECO
DRY AIR INJECTION SYSTEM

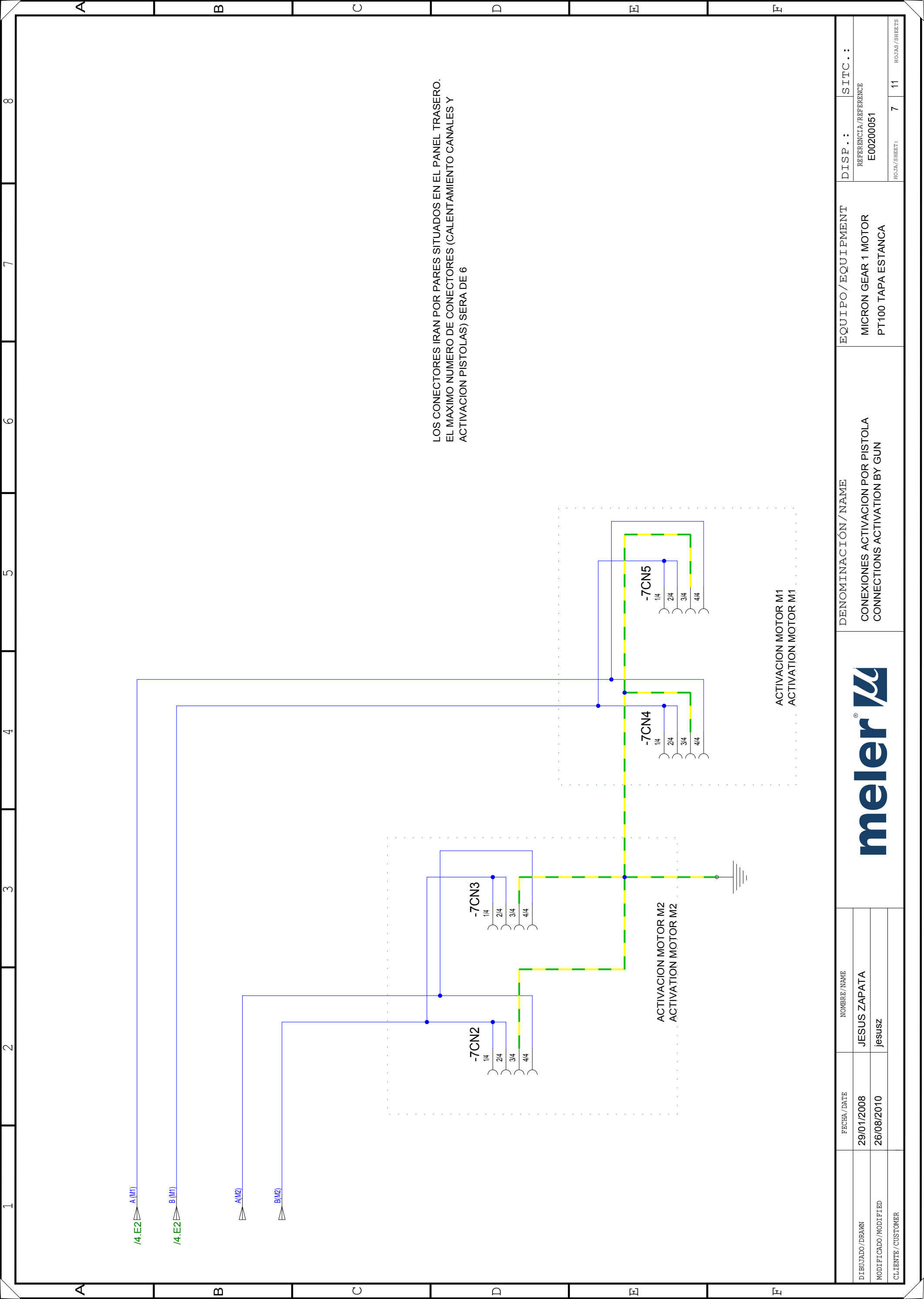

LOS CONECTORES IRAN POR PARES SITUADOS EN EL PANEL TRASERO.
 EL MAXIMO NUMERO DE CONECTORES (CALENTAMIENTO CANALES Y
 ACTIVACION PISTOLAS) SERA DE 6

ACTIVACION MOTOR M1
 ACTIVACION MOTOR M1

ACTIVACION MOTOR M2
 ACTIVACION MOTOR M2

		DENOMINACIÓN / NAME		EQUIPO / EQUIPMENT		DISP. .:		SITC. .:	
NOMBRE / NAME JESUS ZAPATA		CONEXIONES ACTIVACION POR PISTOLA CONNECTIONS ACTIVATION BY GUN		MICRON GEAR 1 MOTOR PT100 TAPA ESTANCA		REFERENCIA / REFERENCE E00200051		HOJA / SHEET: 7 11 HORAS / SHEETS	
FECHA / DATE 29/01/2008	DIBUJADO / DRAWN 26/08/2010	CLIENTE / CUSTOMER jesusz							

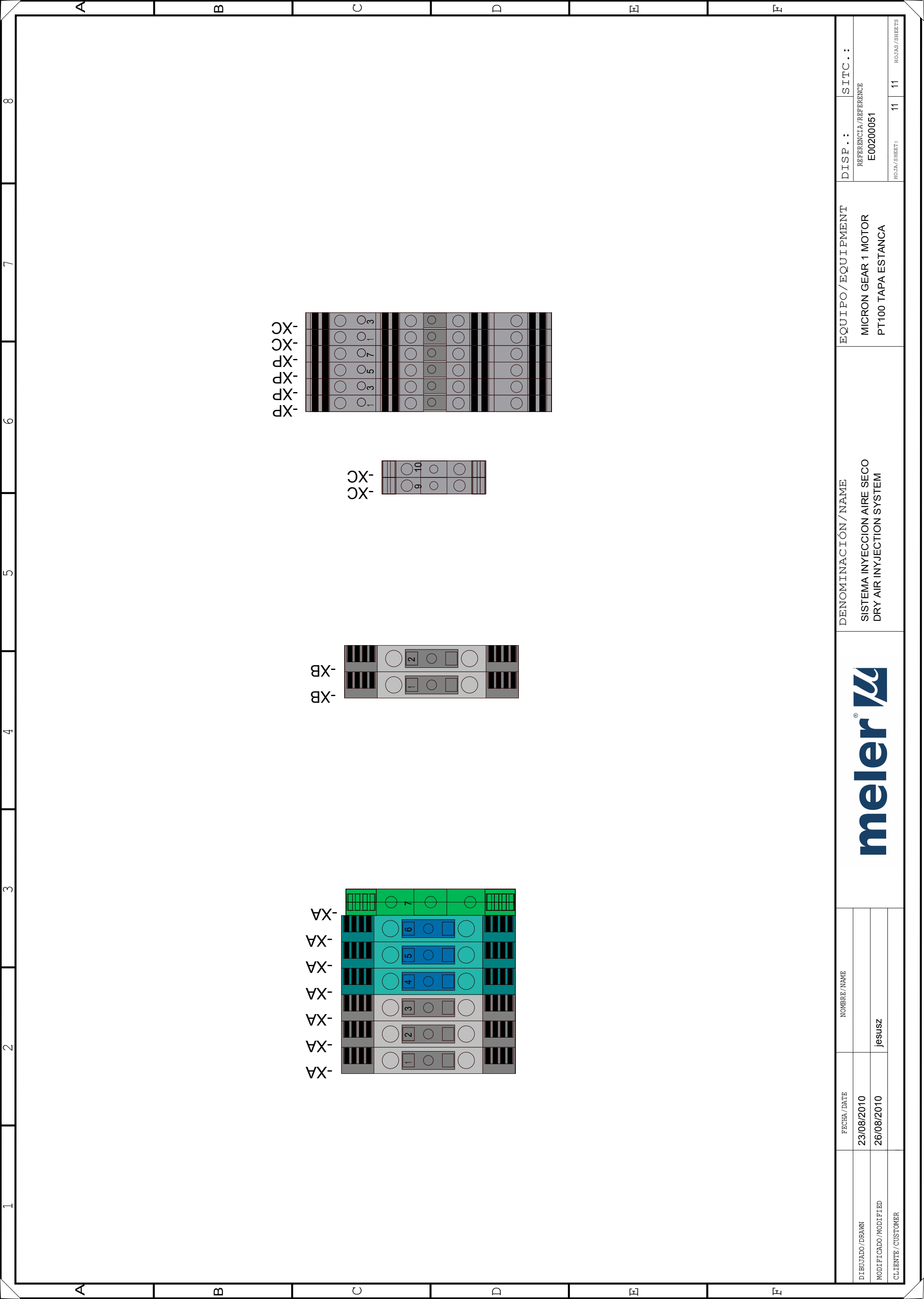

FECHA / DATE		NOMBRE / NAME		EQUIPO / EQUIPMENT		DISP. . :		SITC. . :	
DIBUJADO / DRAWN		23/08/2010		SISTEMA INYECCION AIRE SECO		REFERENCIA / REFERENCE		E00200051	
MODIFICADO / MODIFIED		26/08/2010		DRY AIR INJECTION SYSTEM		HORA / SHEET:		11 11	
CLIENTE / CUSTOMER		jesusz		MICRON GEAR 1 MOTOR		HOURS / SHEETS		11 11	
				PT100 TAPA ESTANCA					



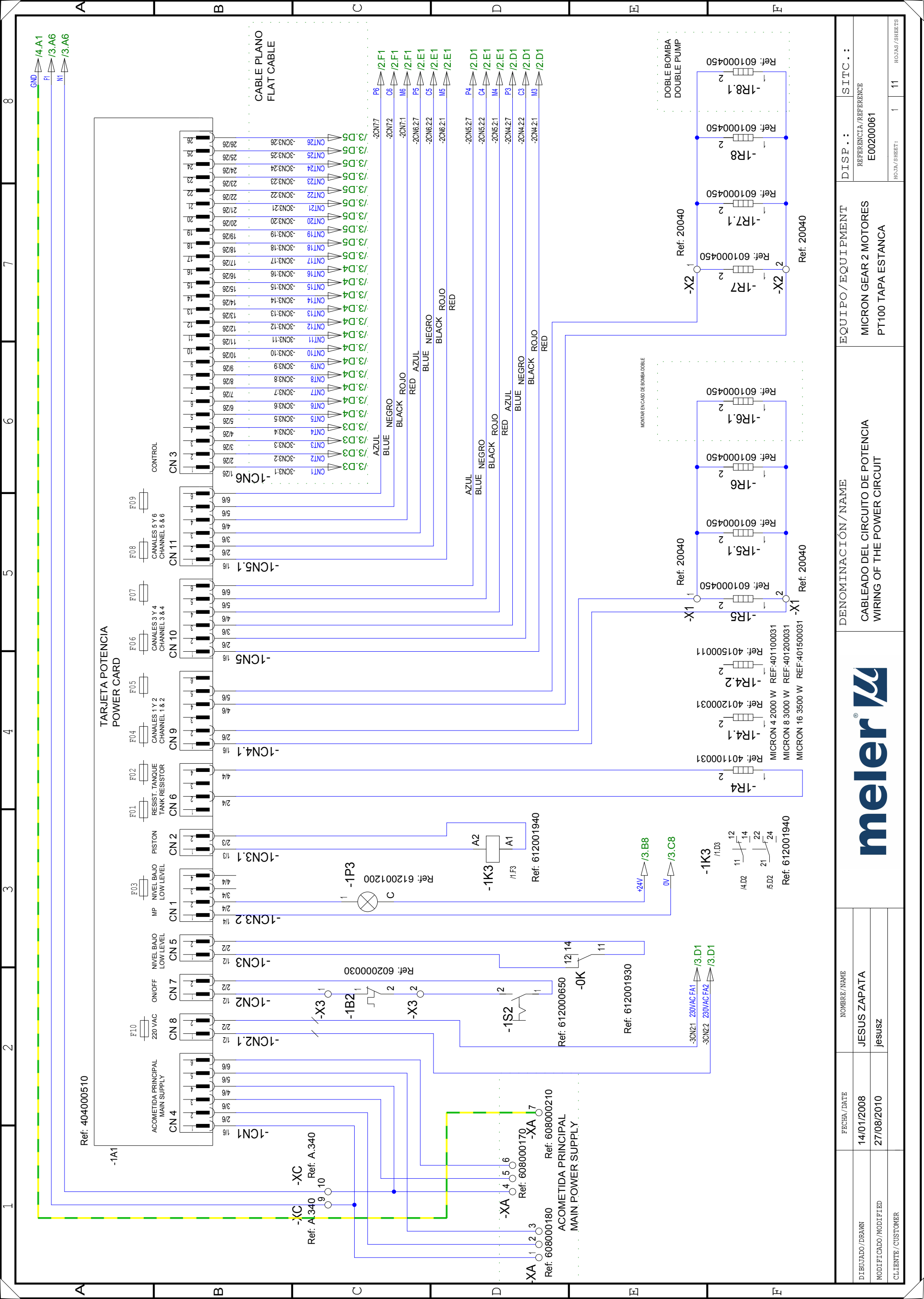

		EQUIPO/EQUIPMENT MICRON GEAR 2 MOTORS PT100 TAPA ESTANCA		DISP.: SITC.: REFERENCIA/REFERENCE E00200061	
DENOMINACIÓN/NAME CABLEADO DEL CIRCUITO DE POTENCIA WIRING OF THE POWER CIRCUIT		FECHA/DATE 14/01/2008		CLIENTE/CUSTOMER JESUS ZAPATA	
MODIFICADO/MODIFIED 27/08/2010		NOMBRE/NAME JESUS ZAPATA		HOURS/SHEETS 1 11	

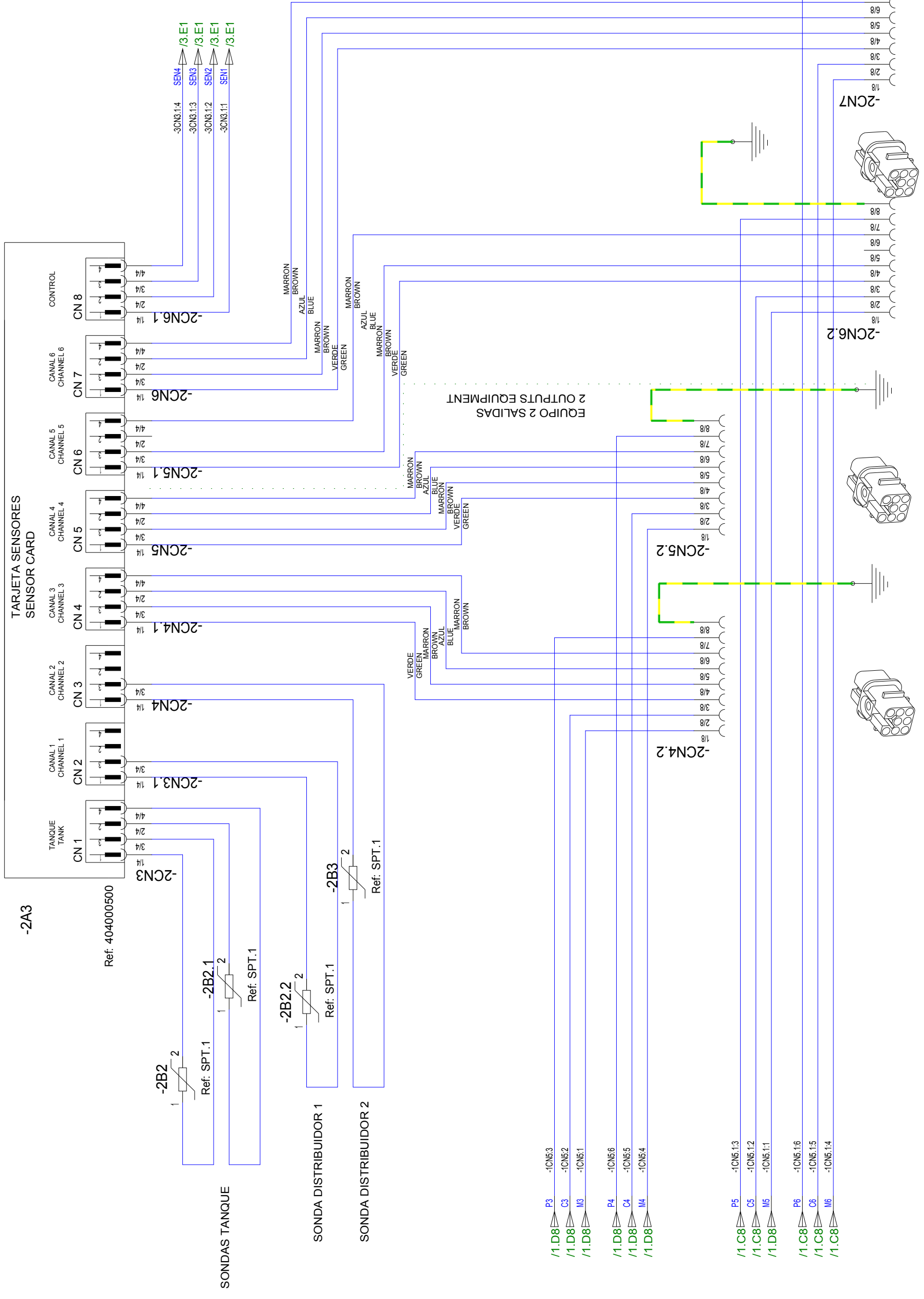

DIBUJADO / DRAWN		FECHA / DATE		NOMBRE / NAME		DENOMINACIÓN / NAME		EQUIPO / EQUIPMENT		DISP. . : SITC. . :	
MODIFICADO / MODIFIED		21/01/2008		JESUS ZAPATA		CABLEADO DEL CIRCUITO DE SENSORES WIRING OF THE SENSOR CIRCUIT		MICRON GEAR 2 MOTORES PT100 TAPA ESTANCA		REFERENCIA / REFERENCE E00200061	
CLIENTE / CUSTOMER		27/08/2010		jesusz						HORA / SHEET: 2 11 HOJAS / SHEETS	



EQUIPO 4 SALIDAS
4 OUTPUTS EQUIPMENT

EQUIPO 2 SALIDAS
2 OUTPUTS EQUIPMENT

TARJETA SENSORES
SENSOR CARD

-2A3

Ref: 404000500

SONDAS TANQUE

SONDA DISTRIBUIDOR 1

SONDA DISTRIBUIDOR 2

/1.D8 P3 -1CN6.3
/1.D8 C3 -1CN6.2
/1.D8 M3 -1CN6.1
/1.D8 P4 -1CN6.6
/1.D8 C4 -1CN6.5
/1.D8 M4 -1CN6.4

/1.C8 P5 -1CN5.1.3
/1.C8 C5 -1CN5.1.2
/1.D8 M5 -1CN5.1.1
/1.C8 P6 -1CN5.1.6
/1.C8 C6 -1CN5.1.5
/1.C8 M6 -1CN5.1.4

-2CN7

-2CN6.2

-2CN5.2

-2CN4.2

-2CN5.1

-2CN4.1

-2CN3.1

-2CN3

-2CN6.1

-2CN5.1

-2CN4.1

-2CN3.1

-2CN2

-2CN1

-2CN6.1

-2CN5.1

-2CN4.1

-2CN3.1

-2CN2

-2CN1

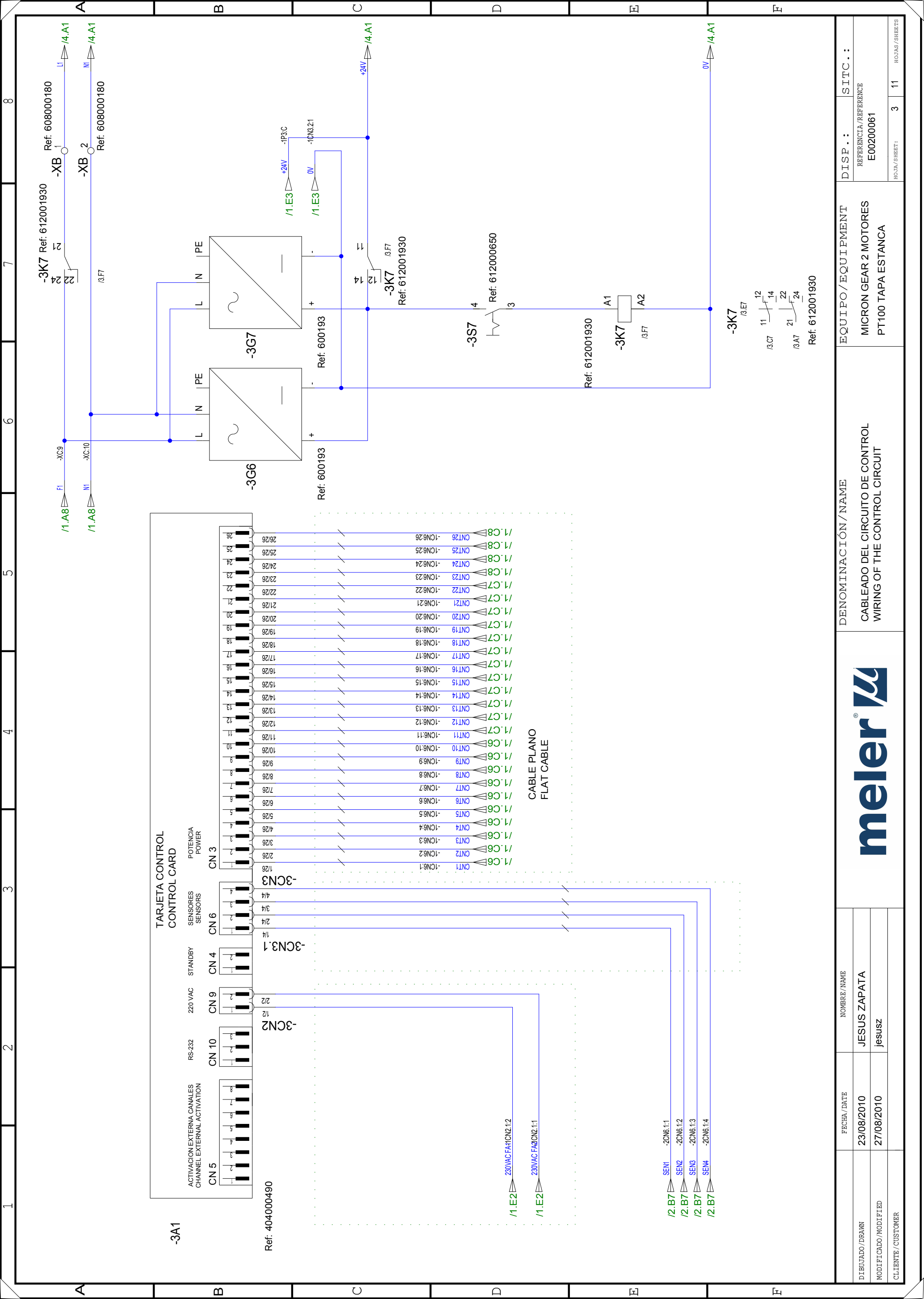

DENOMINACIÓN / NAME
 CABLEADO DEL CIRCUITO DE CONTROL
 WIRING OF THE CONTROL CIRCUIT

EQUIPO / EQUIPMENT
 MICRON GEAR 2 MOTORES
 PT100 TAPA ESTANCA

FECHA / DATE	NOMBRE / NAME	DISP . :	SITC . :
23/08/2010	JESUS ZAPATA	REFERENCIA / REFERENCE	E00200061
27/08/2010	jesusz	HORA / SHEET :	3
CLIENTE / CUSTOMER			11
			HOURS / SHEETS

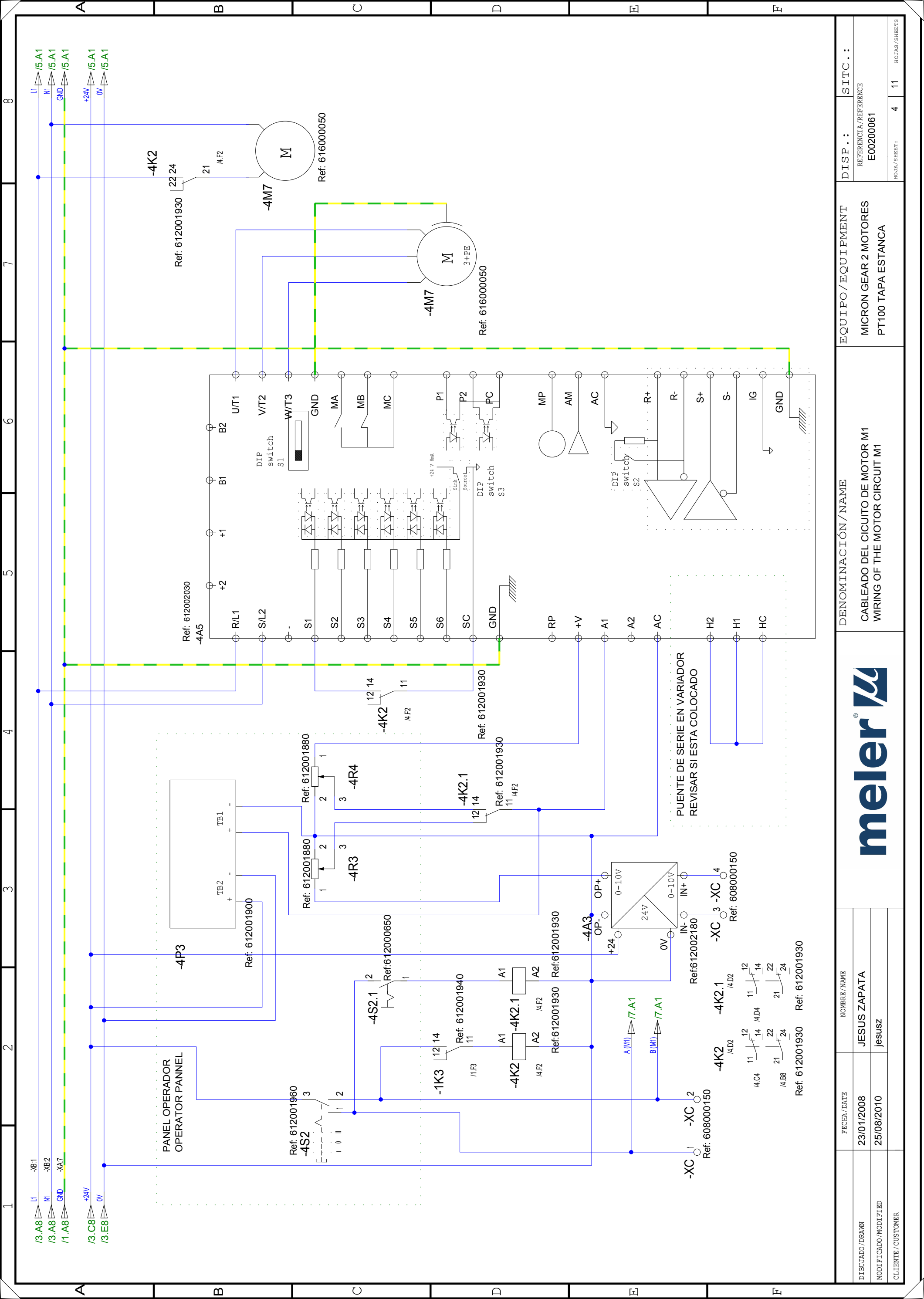

DISP. . :	SITC. . :
REFERENCIA/REFERENCE	E00200061
HORA/SHEET:	4 11

EQUIPO/EQUIPMENT
 MICRON GEAR 2 MOTORES
 PT100 TAPA ESTANCA

DENOMINACIÓN/NAME
 CABLEADO DEL CÍJUTO DE MOTOR M1
 WIRING OF THE MOTOR CIRCUIT M1



FECHA/DATE	NOMBRE/NAME	
23/01/2008	JESUS ZAPATA	
25/08/2010	jesusz	
CLIENTE/CUSTOMER		

PUENTE DE SERIE EN VARIADOR
 REVISAR SI ESTA COLOCADO

Ref: 612001930 Ref: 612001930

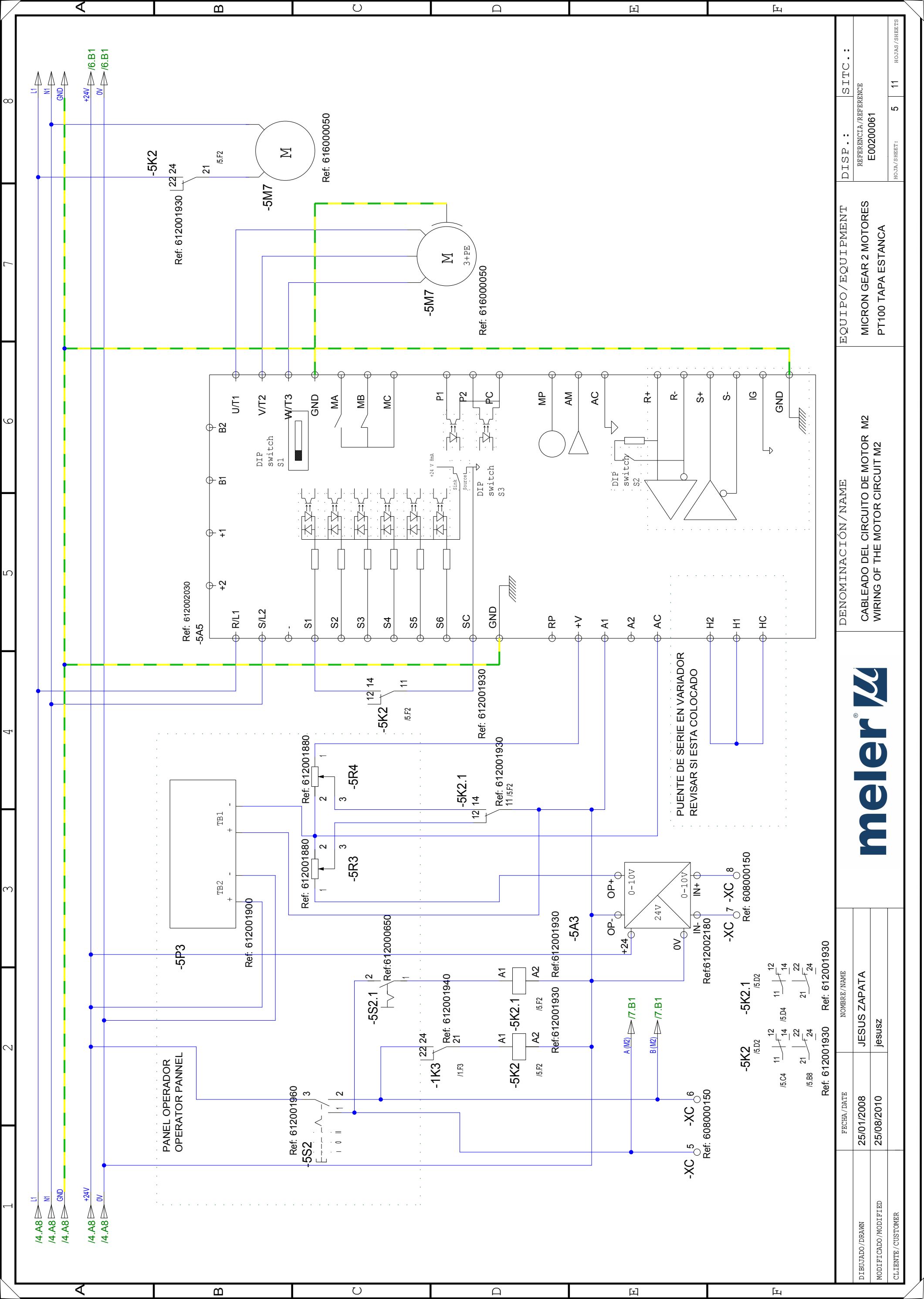

DISP. .:	SITC. .:
REFERENCIA/REFERENCE	E00200061
HORA/SHEET:	5 11
HOJAS/SHEETS	

EQUIPO/EQUIPMENT
 MICRON GEAR 2 MOTORES
 PT100 TAPA ESTANCA

DENOMINACIÓN/NAME
 CABLEADO DEL CIRCUITO DE MOTOR M2
 WIRING OF THE MOTOR CIRCUIT M2



FECHA/DATE	25/01/2008	REF: 612001930
DIBUJADO/DRAWN	JESUS ZAPATA	Ref: 612001930
MODIFICADO/MODIFIED	jesusz	Ref: 612001930
CLIENTE/CUSTOMER		

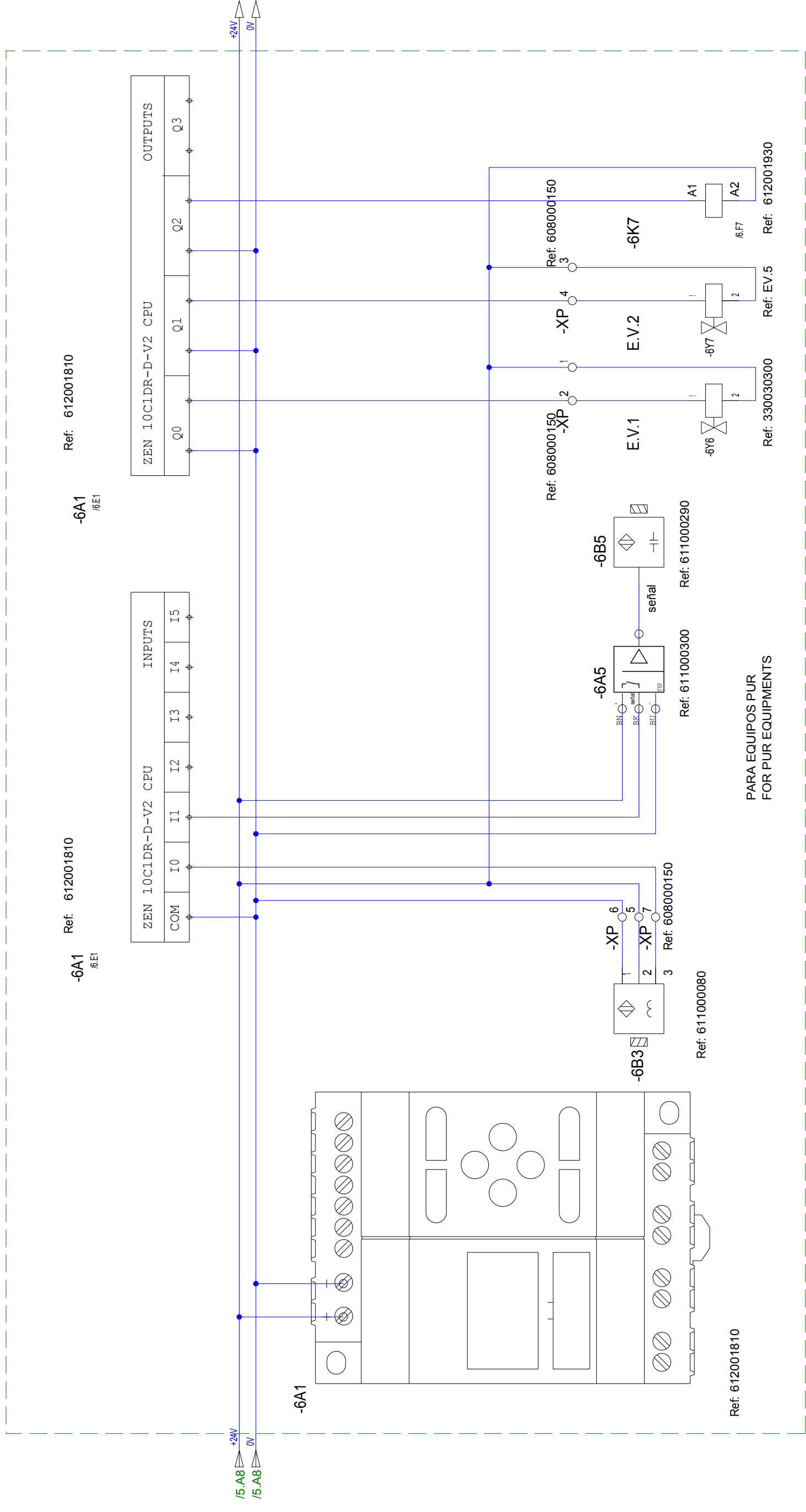

-6K7
 /6E7
 11 12
 14
 21 22
 24
 Ref: 612001930

PARA EQUIPOS PUR
 FOR PUR EQUIPMENTS

FECHA / DATE		NOMBRE / NAME	
23/08/2010		JESUS ZAPATA	
MODIFICADO / MODIFIED		jesusz	
CLIENTE / CUSTOMER			
DENOMINACIÓN / NAME		EQUIPO / EQUIPMENT	
SISTEMA INYECCION AIRE SECO DRY AIR INJECTION SYSTEM		MICRON GEAR 2 MOTORES PT100 TAPA ESTANCA	
DISP . . :		SITC . . :	
E00200061		E00200061	
HORAS / SHEETS: 6		HORAS / SHEETS: 11	



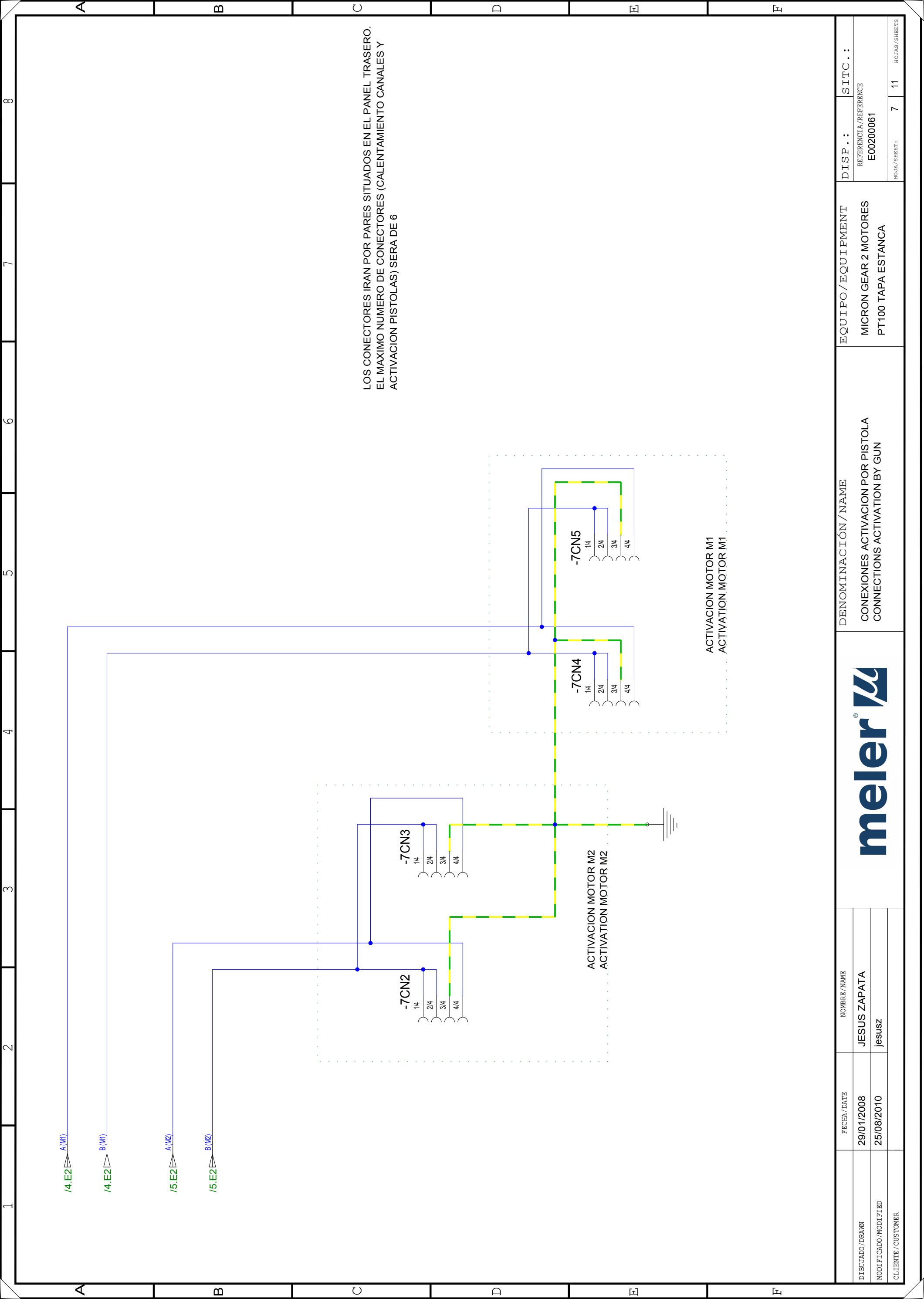

LOS CONECTORES IRAN POR PARES SITUADOS EN EL PANEL TRASERO.
 EL MAXIMO NUMERO DE CONECTORES (CALENTAMIENTO CANALES Y
 ACTIVACION PISTOLAS) SERA DE 6

FECHA / DATE		NOMBRE / NAME	
29/01/2008		JESUS ZAPATA	
25/08/2010		jesusz	
DIBUJADO / DRAWN		CLIENTE / CUSTOMER	
MODIFICADO / MODIFIED			
DENOMINACIÓN / NAME		EQUIPO / EQUIPMENT	
CONEXIONES ACTIVACION POR PISTOLA CONNECTIONS ACTIVATION BY GUN		MICRON GEAR 2 MOTORES PT100 TAPA ESTANCA	
DISP. .:		SITC. .:	
REFERENCIA / REFERENCE E00200061		7	
HOJA / SHEET:		11	
		HOURS / SHEETS	



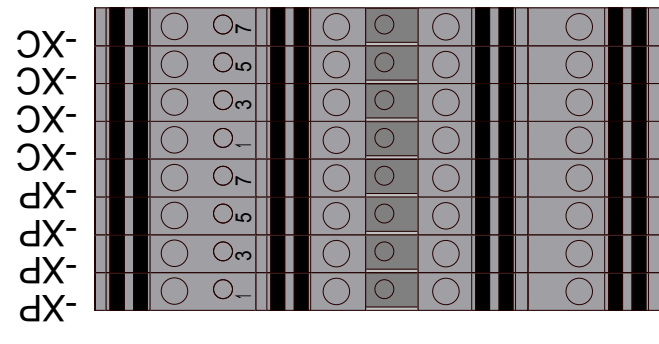
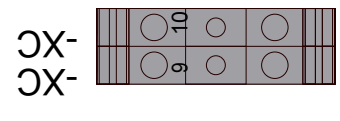
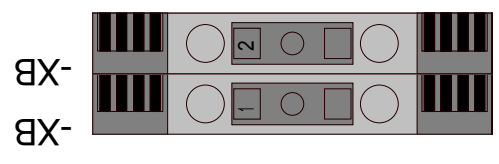
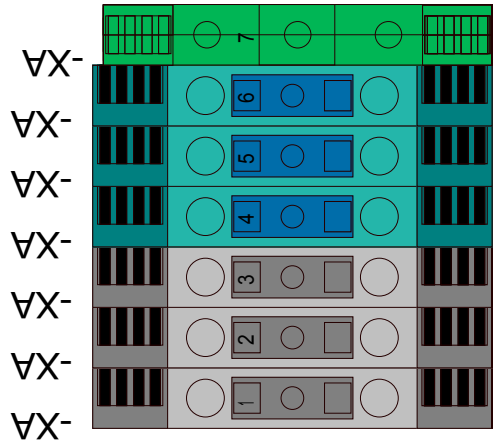
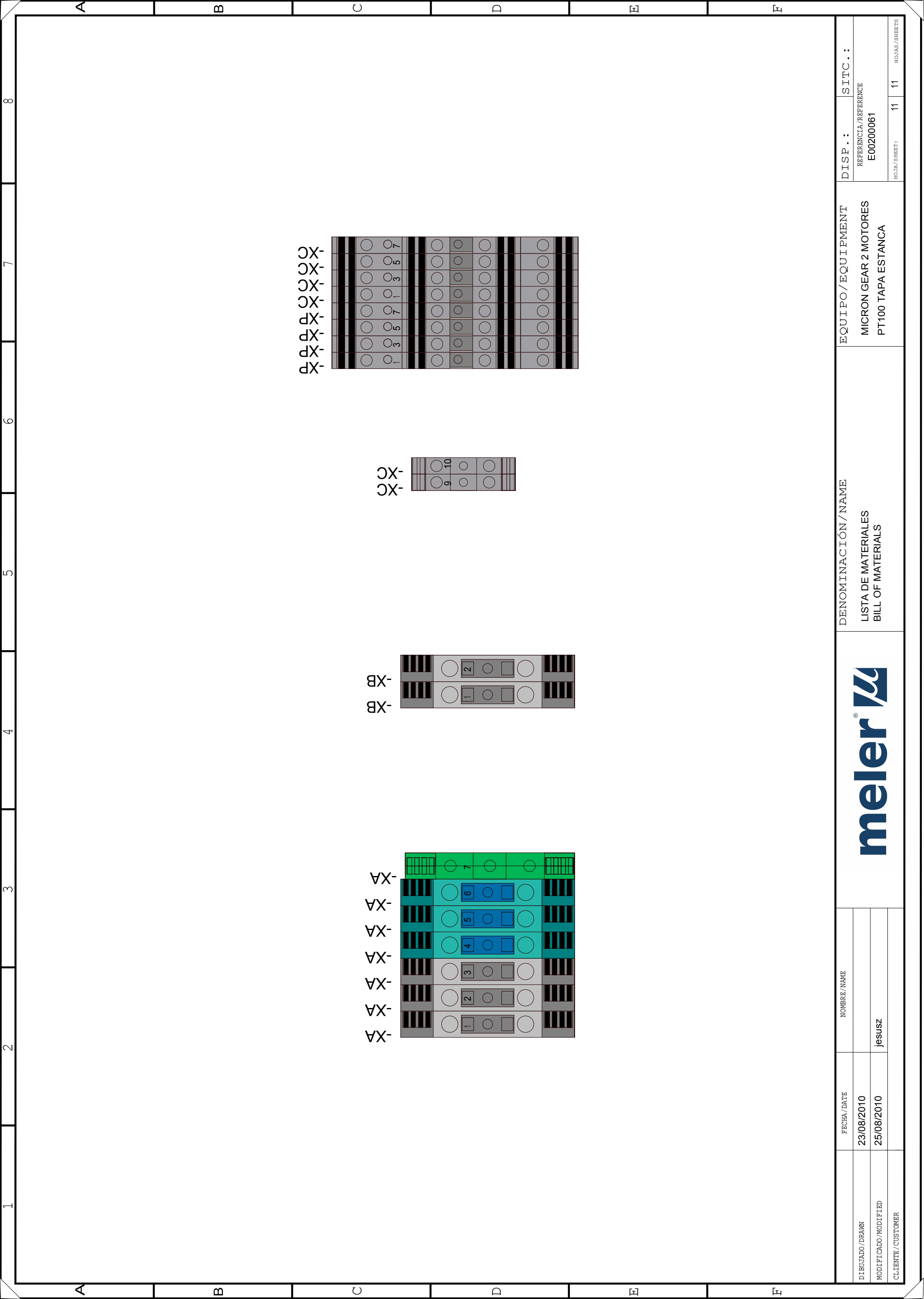

	FECHA / DATE	NOMBRE / NAME	EQUIPO / EQUIPMENT	DISP. . :	SITC. . :
	23/08/2010		MICRON GEAR 2 MOTORES	REFERENCIA / REFERENCE	
	25/08/2010	jesusz	PT100 TAPA ESTANCA	E00200061	
DIBUJADO / DRAWN				HORA / SHEET:	11 11
MODIFICADO / MODIFIED				HOURS / SHEETS	
CLIENTE / CUSTOMER					



DENOMINACIÓN / NAME
 LISTA DE MATERIALES
 BILL OF MATERIALS

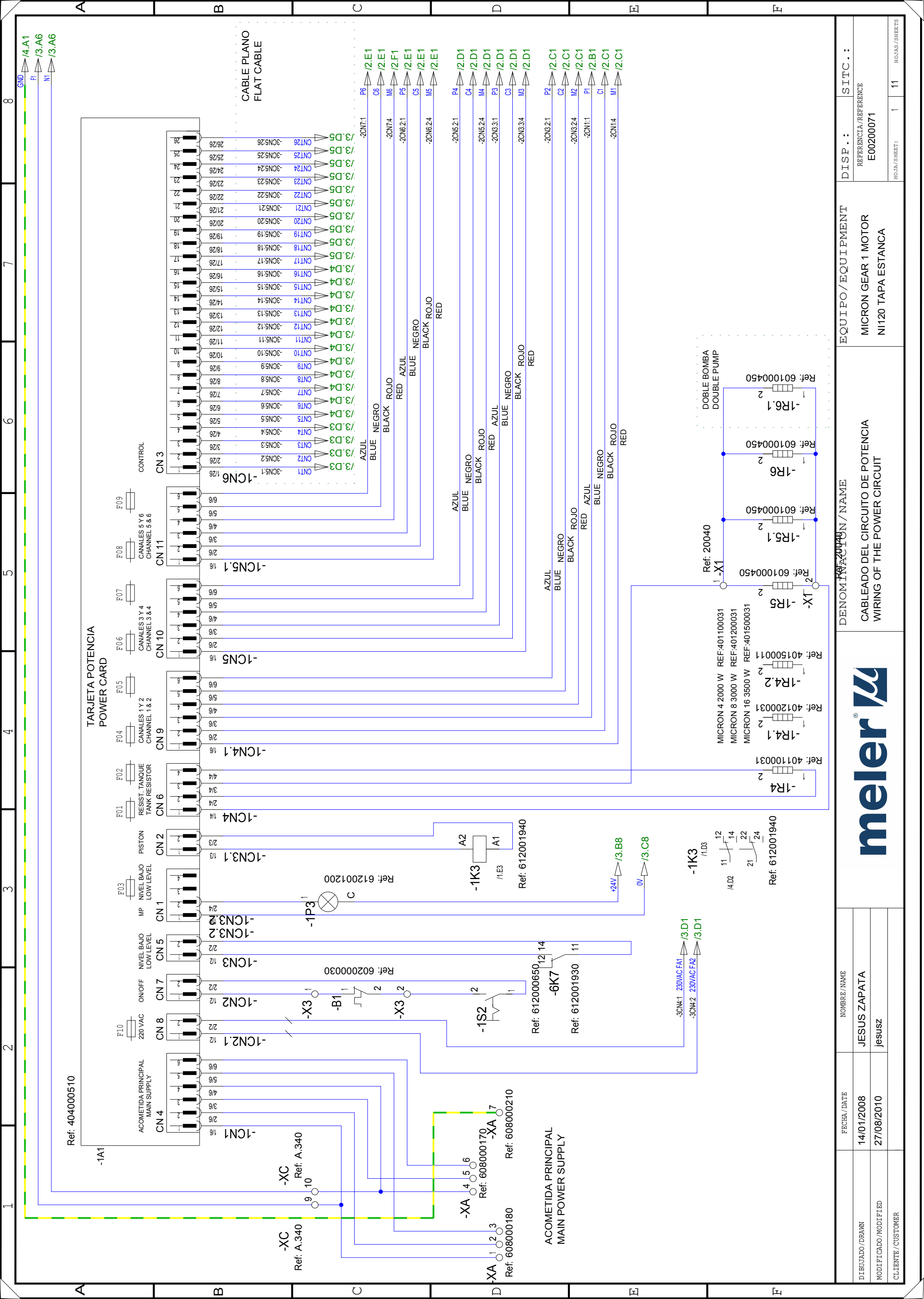

FECHA / DATE	14/01/2008
DISEÑADO / DRAWN	JESUS ZAPATA
MODIFICADO / MODIFIED	jesusz
CLIENTE / CUSTOMER	

DENOMINACION / NAME	
CABLEADO DEL CIRCUITO DE POTENCIA WIRING OF THE POWER CIRCUIT	

EQUIPO / EQUIPMENT	
MICRON GEAR 1 MOTOR N120 TAPA ESTANCA	

DISP. . :	SITC. . :
REFERENCIA / REFERENCE	E00200071
HORA / SHEET:	1 11
HORAS / SHEETS	

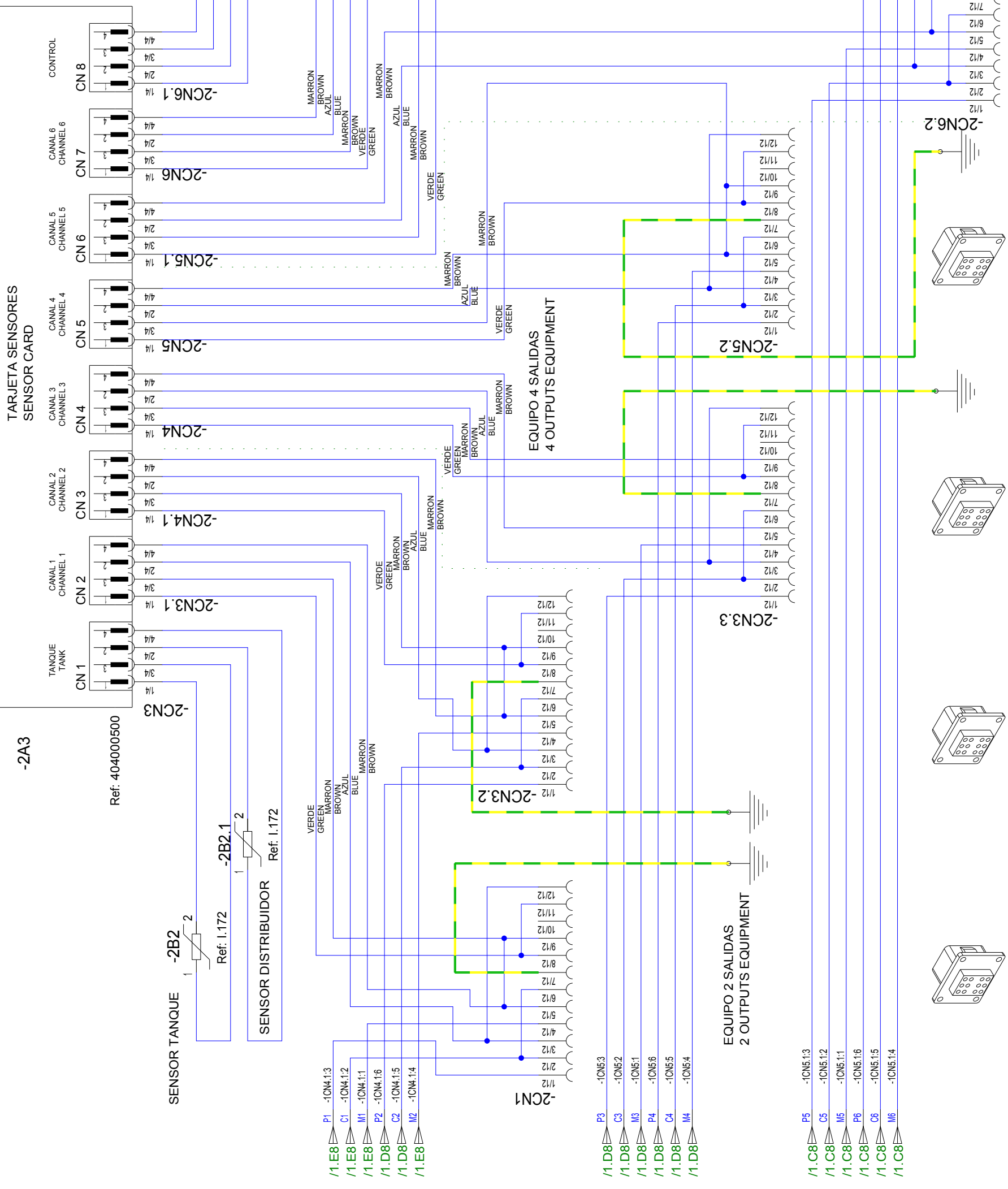

-2A3

Ref: 404000500

SENSOR DISTRIBUIDOR Ref. I.172

		DENOMINACIÓN / NAME CABLEADO DEL CIRCUITO DE SENSORES WIRING OF THE SENSOR CIRCUIT		EQUIPO / EQUIPMENT MICRON GEAR 1 MOTOR N1120 TAPA ESTANCA		DISP.: SITC.: REFERENCIA / REFERENCE E00200071
FECHA / DATE 28/01/2008	NOMBRE / NAME JESUS ZAPATA					HOJA / SHEET: 2
MODIFICADO / MODIFIED 25/08/2010	CLIENTE / CUSTOMER jesusz					HOJAS / SHEETS 11

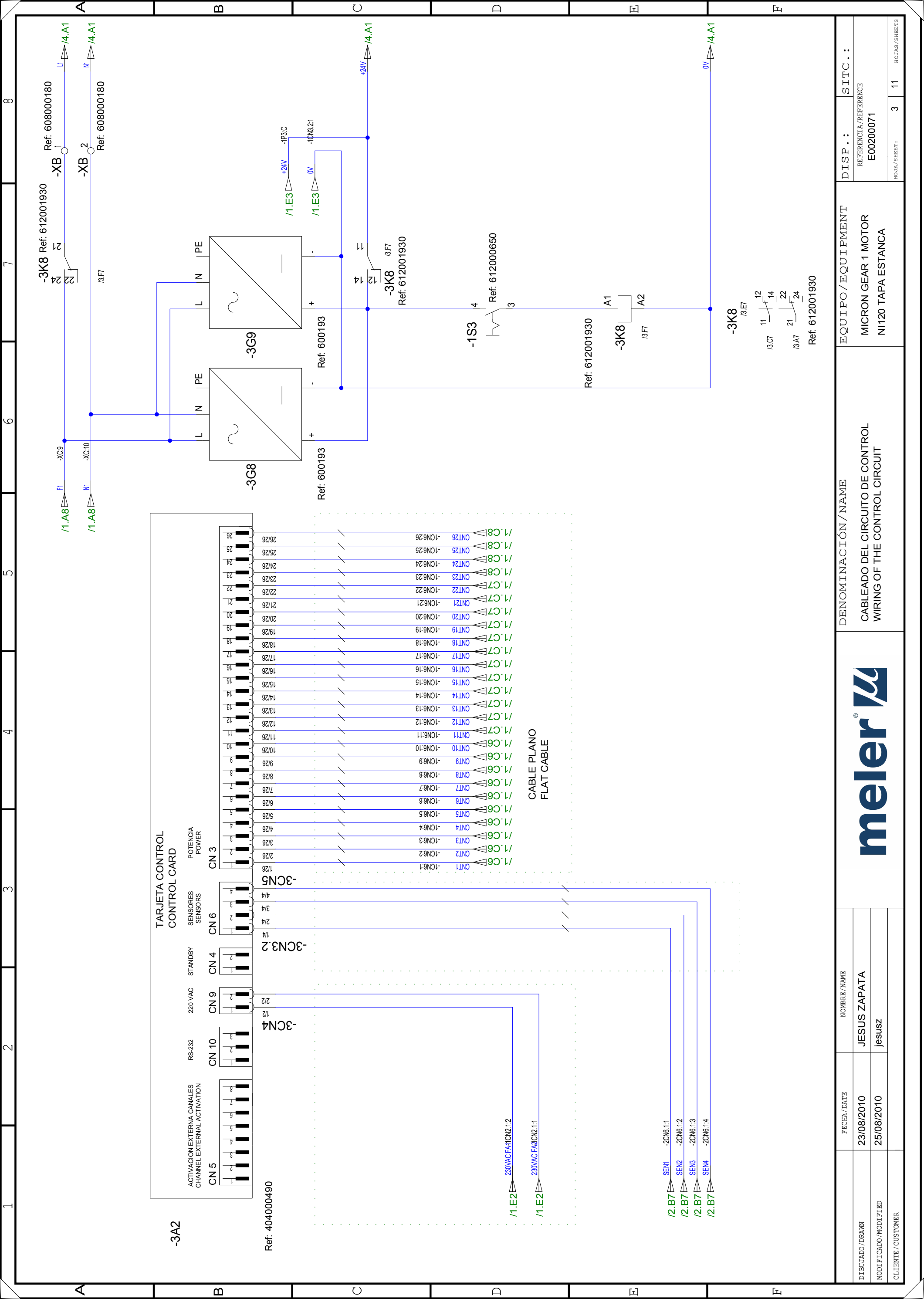

DISP. .:	SITC. .:
REFERENCIA/REFERENCE	E00200071
HORA/SHEET:	3 11

EQUIPO/EQUIPMENT
 MICRON GEAR 1 MOTOR
 N1120 TAPA ESTANCA

DENOMINACIÓN/NAME
 CABLEADO DEL CIRCUITO DE CONTROL
 WIRING OF THE CONTROL CIRCUIT

FECHA/DATE	23/08/2010	NOMBRE/NAME	JESUS ZAPATA
DIBUJADO/DRAWN	25/08/2010	CLIENTE/CUSTOMER	jesusz



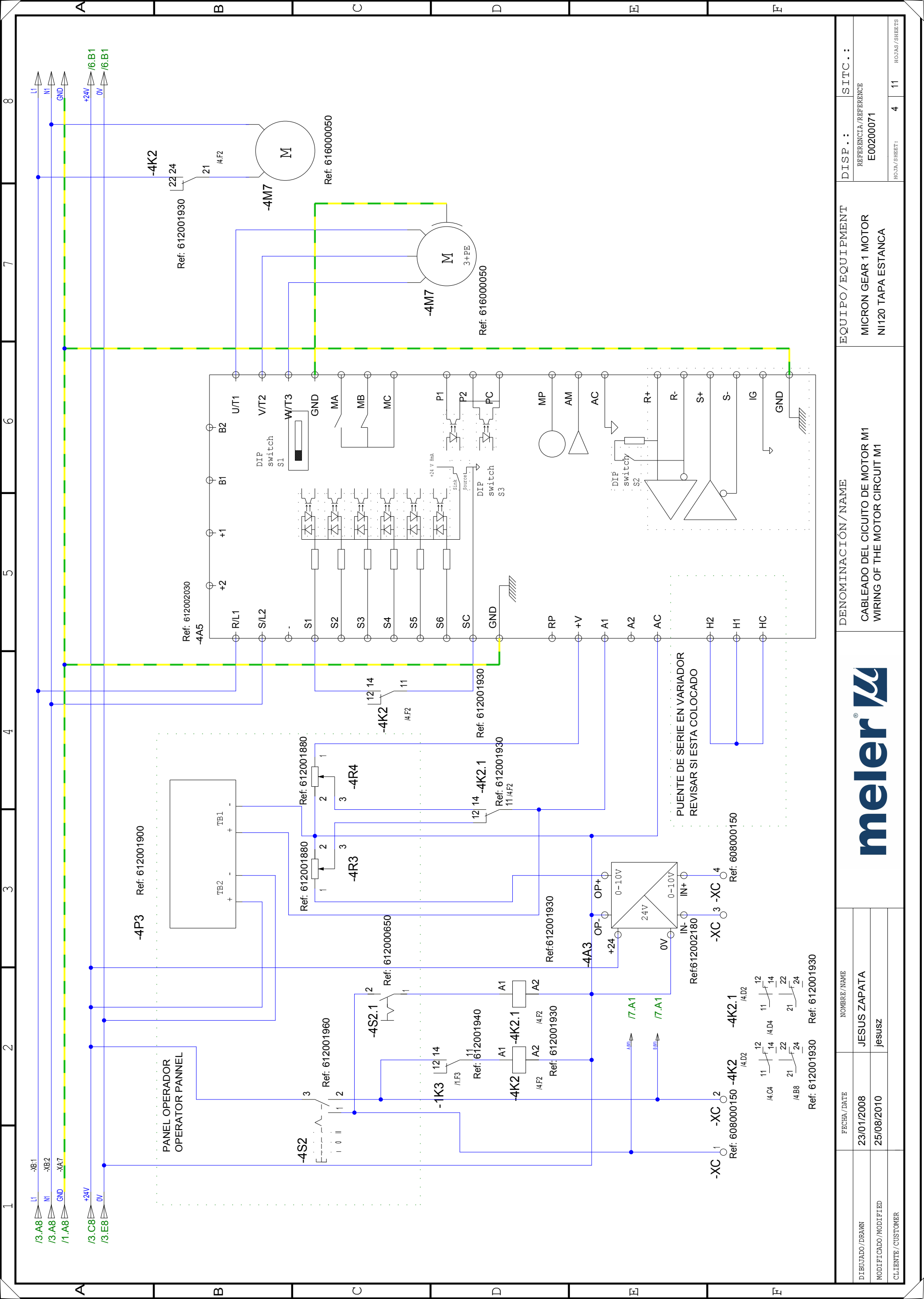

DISP. . :	SITC. . :
REFERENCIA/REFERENCE	E00200071
HOJA/SHEET:	4 11

EQUIPO/EQUIPMENT
MICRON GEAR 1 MOTOR
 N1120 TAPA ESTANCA

DENOMINACIÓN/NAME
CABLEADO DEL CÍJUTO DE MOTOR M1
WIRING OF THE MOTOR CIRCUIT M1



FECHA/DATE	NOMBRE/NAME
23/01/2008	JESUS ZAPATA
25/08/2010	jesusz
CLIENTE/CUSTOMER	

Ref: 612001930 Ref: 612001930

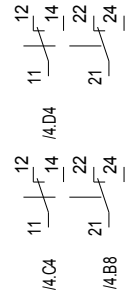

PUENTE DE SERIE EN VARIADOR
 REVISAR SI ESTA COLOCADO

	1	2	3	4	5	6	7	8										
A																		
B																		
C																		
D																		
E																		
F																		
	<table border="1"> <thead> <tr> <th>FECHA / DATE</th> <th>NOMBRE / NAME</th> </tr> </thead> <tbody> <tr> <td>29/01/2008</td> <td>JESUS ZAPATA</td> </tr> <tr> <td>25/08/2010</td> <td>jesusz</td> </tr> </tbody> </table>			FECHA / DATE	NOMBRE / NAME	29/01/2008	JESUS ZAPATA	25/08/2010	jesusz				DENOMINACIÓN / NAME RESERVA RESERVE		EQUIPO / EQUIPMENT MICRON GEAR 1 MOTOR N1120 TAPA ESTANCA		DISP.: REFERENCIA / REFERENCE E00200071	SITC.: HORA / SHEET: 5 11 HOURS / SHEETS
FECHA / DATE	NOMBRE / NAME																	
29/01/2008	JESUS ZAPATA																	
25/08/2010	jesusz																	

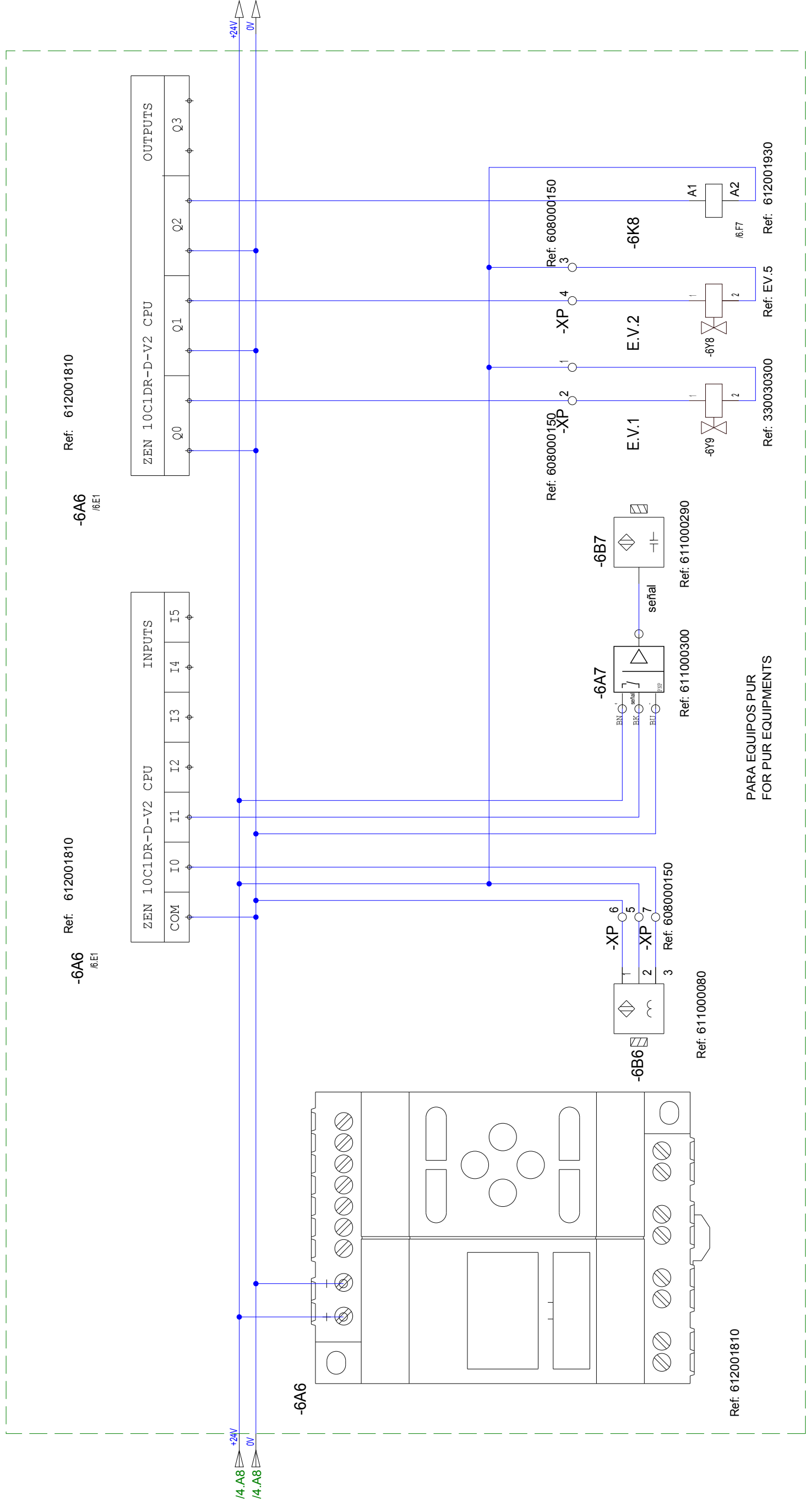

-6A6
/6E1
Ref: 612001810

-6A6
/6E1
Ref: 612001810

ZEN 10C1DR-D-V2 CPU						INPUTS			
COM	I0	I1	I2	I3	I4	I5			

ZEN 10C1DR-D-V2 CPU				OUTPUTS		
Q0	Q1	Q2	Q3			

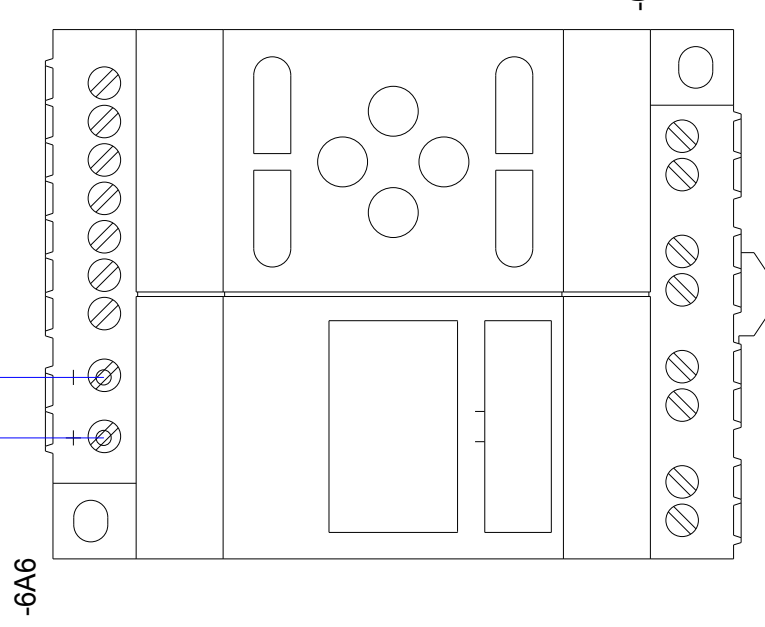

Ref: 612001810

Ref: 611000300

Ref: 611000290

Ref: 608000150

Ref: 608000150

PARA EQUIPOS PUR
FOR PUR EQUIPMENTS

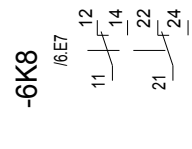

FECHA / DATE	NOMBRE / NAME	EQUIPO / EQUIPMENT	DISP . : REFERENCIA / REFERENCE	SITC . :
23/08/2010	JESUS ZAPATA	MICRON GEAR 1 MOTOR	E00200071	
25/08/2010	jesusz	N1120 TAPA ESTANCA		
CLIENTE / CUSTOMER		HORAS / SHEETS: 6		11

DENOMINACIÓN / NAME
SISTEMA INYECCION AIRE SECO
DRY AIR INJECTION SYSTEM



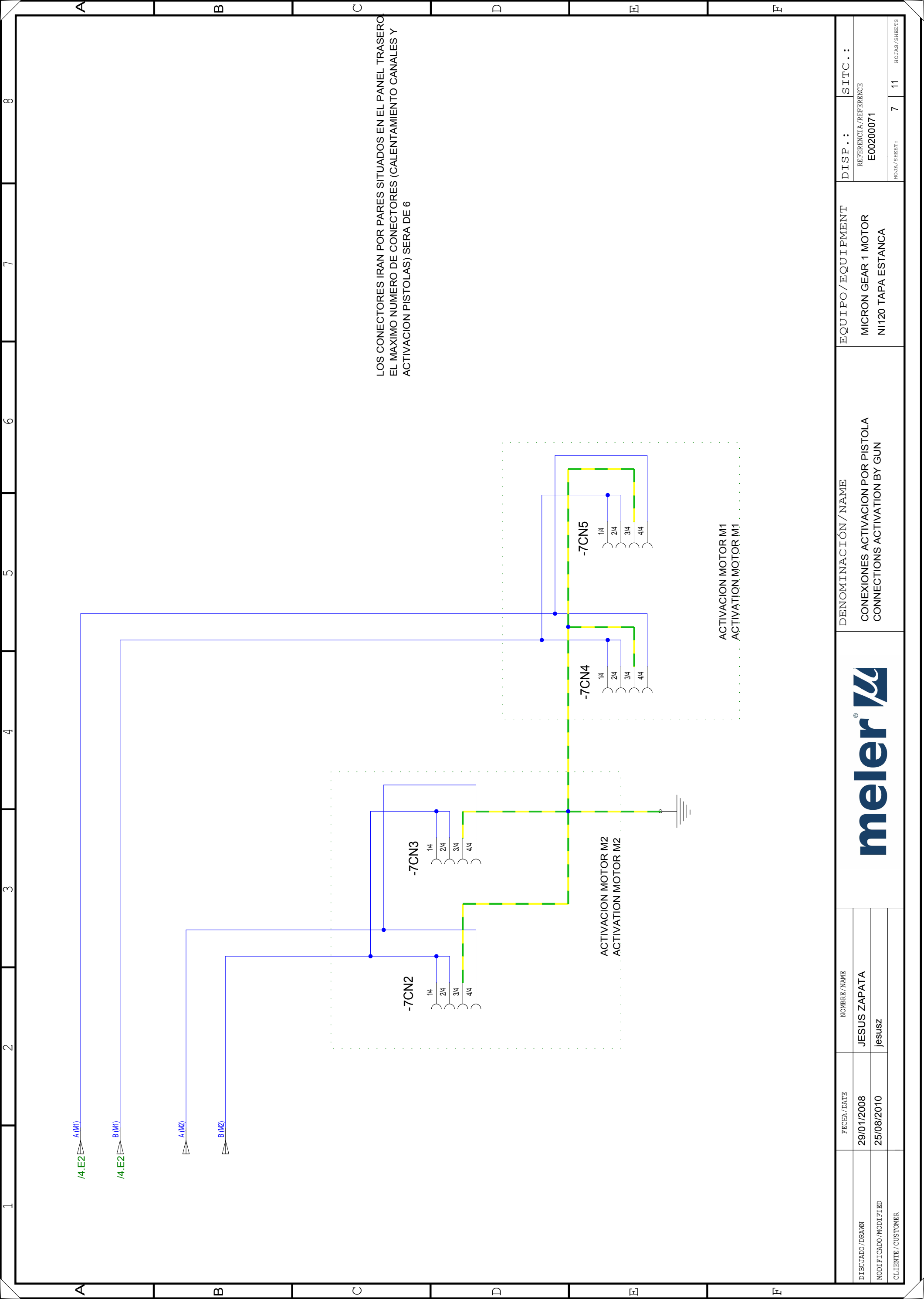

LOS CONECTORES IRAN POR PARES SITUADOS EN EL PANEL TRASERO
 EL MAXIMO NUMERO DE CONECTORES (CALENTAMIENTO CANALES Y
 ACTIVACION PISTOLAS) SERA DE 6

		DENOMINACIÓN / NAME CONEXIONES ACTIVACION POR PISTOLA CONNECTIONS ACTIVATION BY GUN		EQUIPO / EQUIPMENT MICRON GEAR 1 MOTOR N1120 TAPA ESTANCA		DISP.: SITC.: REFERENCIA / REFERENCE E00200071	
FECHA / DATE	NOMBRE / NAME					HOJA / SHEET: 7 11 HORAS / SHEETS	
29/01/2008	JESUS ZAPATA						
25/08/2010	jesusz						
DIBUJADO / DRAWN							
MODIFICADO / MODIFIED							
CLIENTE / CUSTOMER							

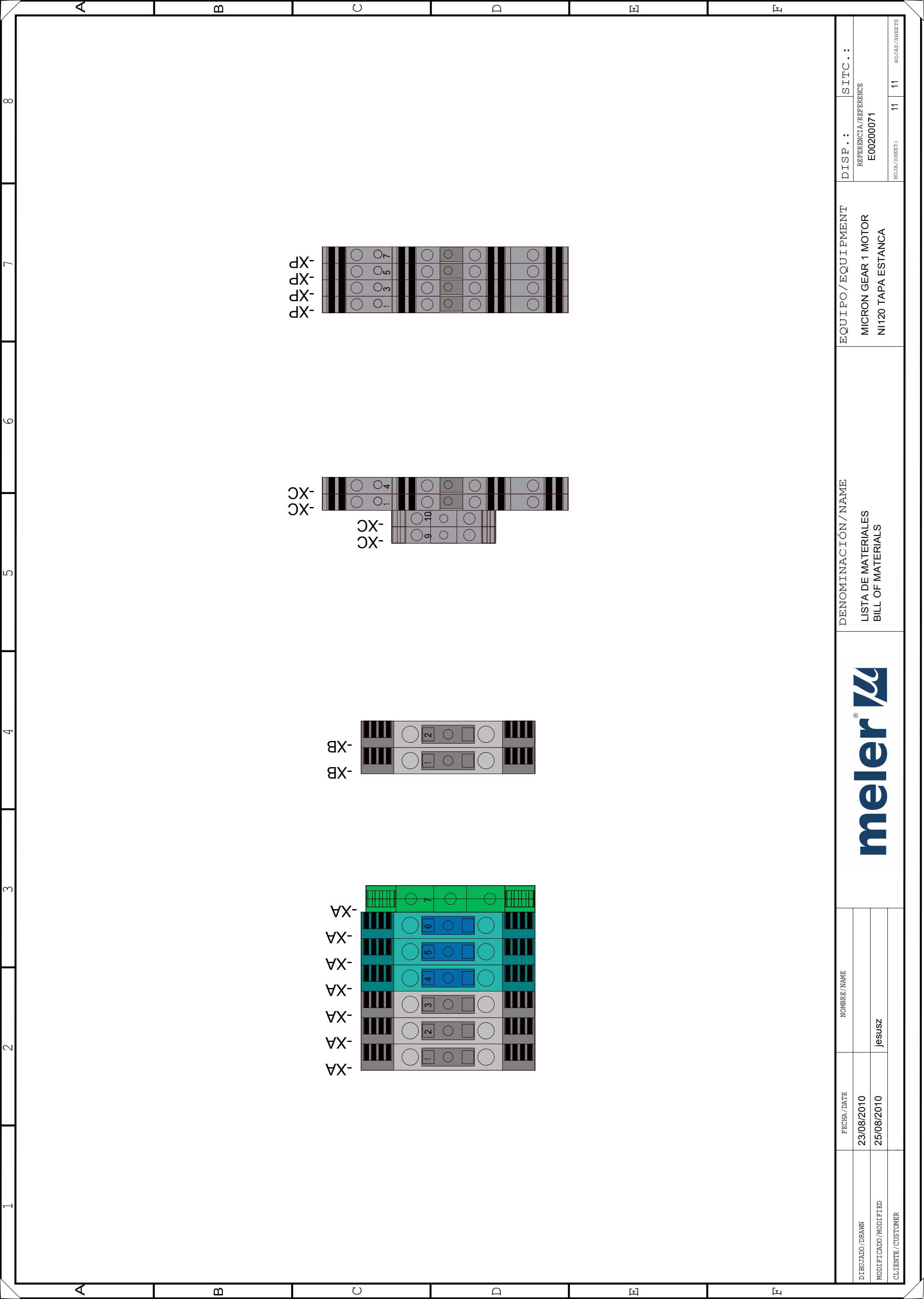



A		B		C		D		E		F	
1	2	3	4	5	6	7	8				
DENOMINACIÓN / NAME										EQUIPO / EQUIPMENT	
LISTA DE MATERIALES BILL OF MATERIALS										MICRON GEAR 1 MOTOR N1120 TAPA ESTANCA	
FECHA / DATE										DISP .:	SITC .:
DIBUJADO / DRAWN	23/08/2010									REFERENCIA / REFERENCE E00200071	
MODIFICADO / MODIFIED	25/08/2010									HOJA / SHEET:	11
CLIENTE / CUSTOMER	jesusz									HORAS / SHEETS	11

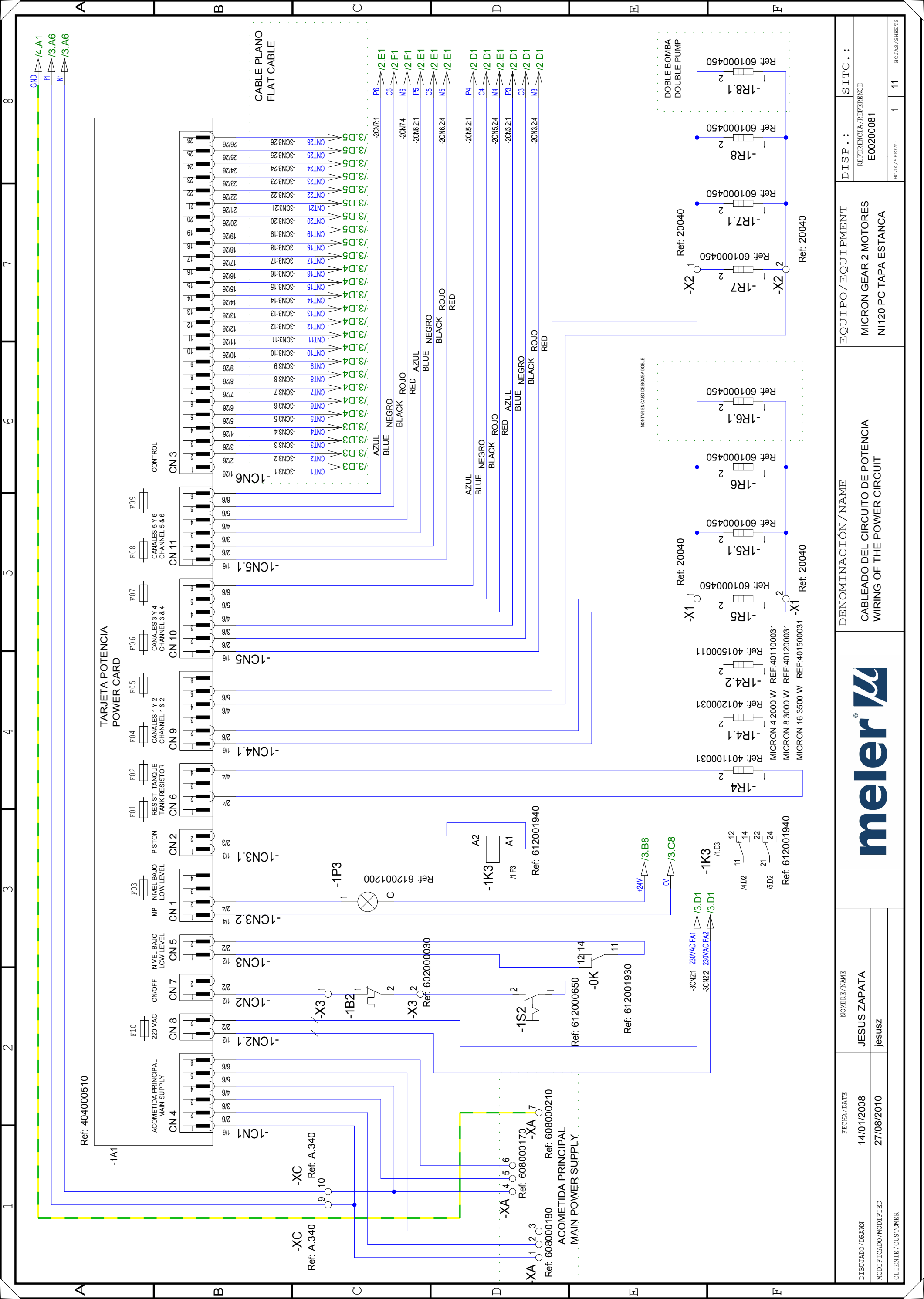

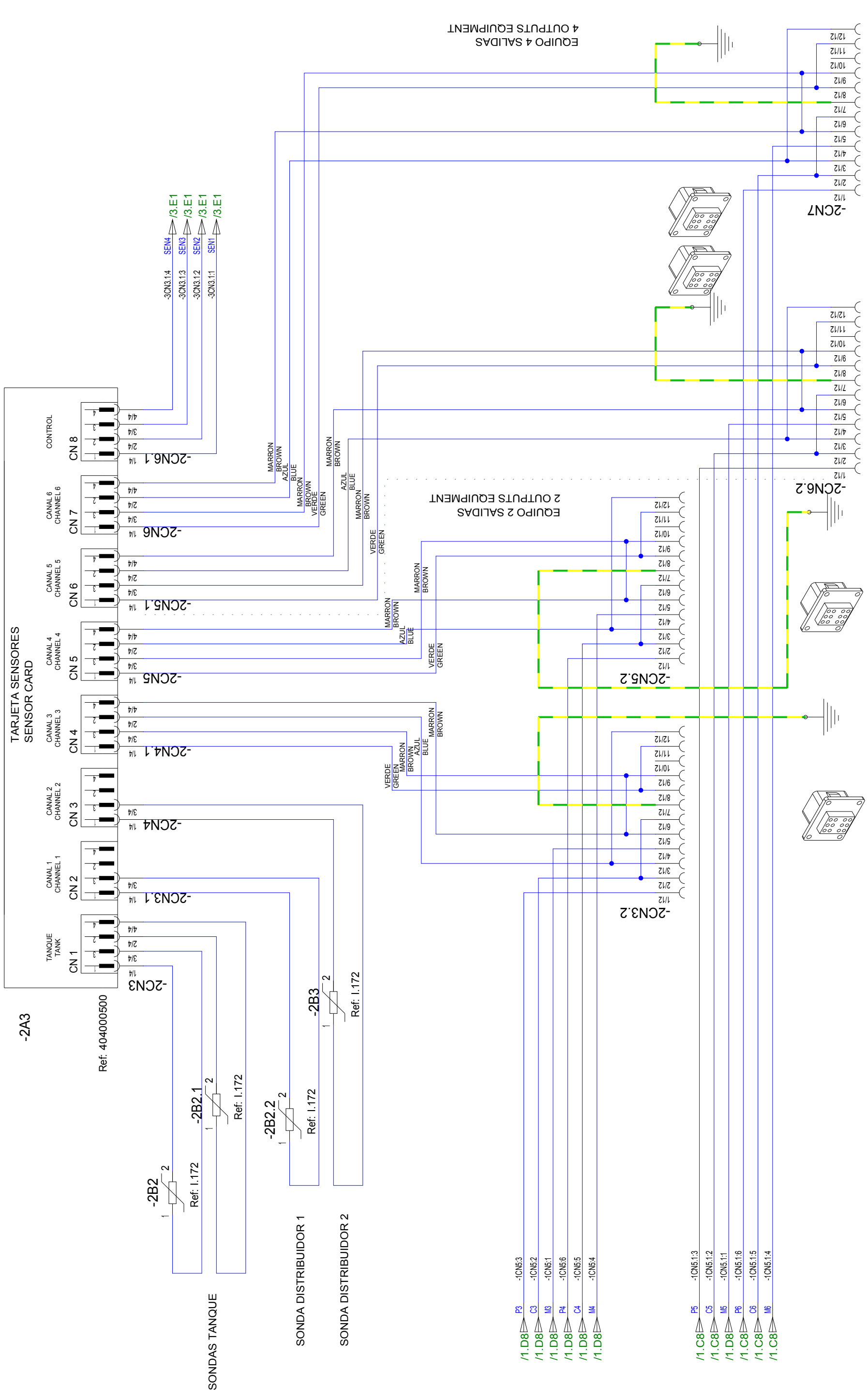

FECHA/DATE	NOMBRE/NAME
14/01/2008	JESUS ZAPATA
27/08/2010	jesusz



		DENOMINACIÓN / NAME		EQUIPO / EQUIPMENT		DISP. : SITC. :	
CABLEADO DEL CIRCUITO DE SENSORES WIRING OF THE SENSOR CIRCUIT		MICRON GEAR 2 MOTORES N120 PC TAPA ESTANCA		E00200081		2 11	
JESUS ZAPATA		NOMBRE / NAME		REFERENCIA / REFERENCE		HORAS / SHEETS	
jesusz		JESUS ZAPATA		E00200081		2 11	
27/08/2010		FECHA / DATE		EQUIPO / EQUIPMENT		HORAS / SHEETS	
21/01/2008		27/08/2010		MICRON GEAR 2 MOTORES N120 PC TAPA ESTANCA		2 11	
DIBUJADO / DRAWN		MODIFICADO / MODIFIED		CLIENTE / CUSTOMER		HORAS / SHEETS	
21/01/2008		27/08/2010		JESUS ZAPATA		2 11	
jesusz		JESUS ZAPATA		E00200081		2 11	

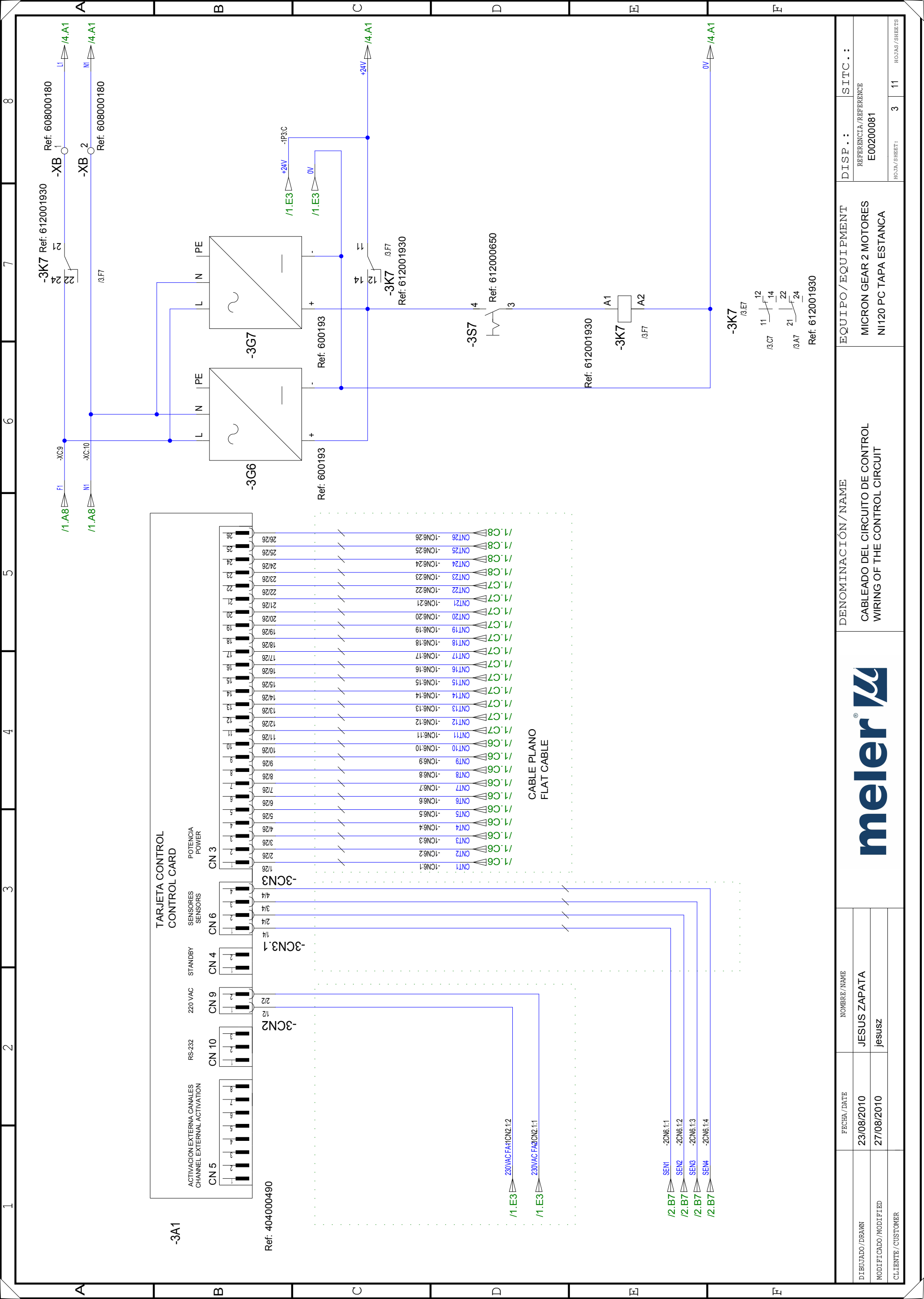

DISP.:	SITC.:
REFERENCIA/REFERENCE	E00200081
HORA/SHEET:	3 11
HORAS/SHEETS	

EQUIPO/EQUIPMENT	MICRON GEAR 2 MOTORES N1120 PC TAPA ESTANCA
DENOMINACIÓN/NAME	CABLEADO DEL CIRCUITO DE CONTROL WIRING OF THE CONTROL CIRCUIT

FECHA/DATE	23/08/2010	NOMBRE/NAME	JESUS ZAPATA
DIBUJADO/DRAWN	27/08/2010	CLIENTE/CUSTOMER	jesusz
MODIFICADO/MODIFIED			
CLIENTE/CUSTOMER			



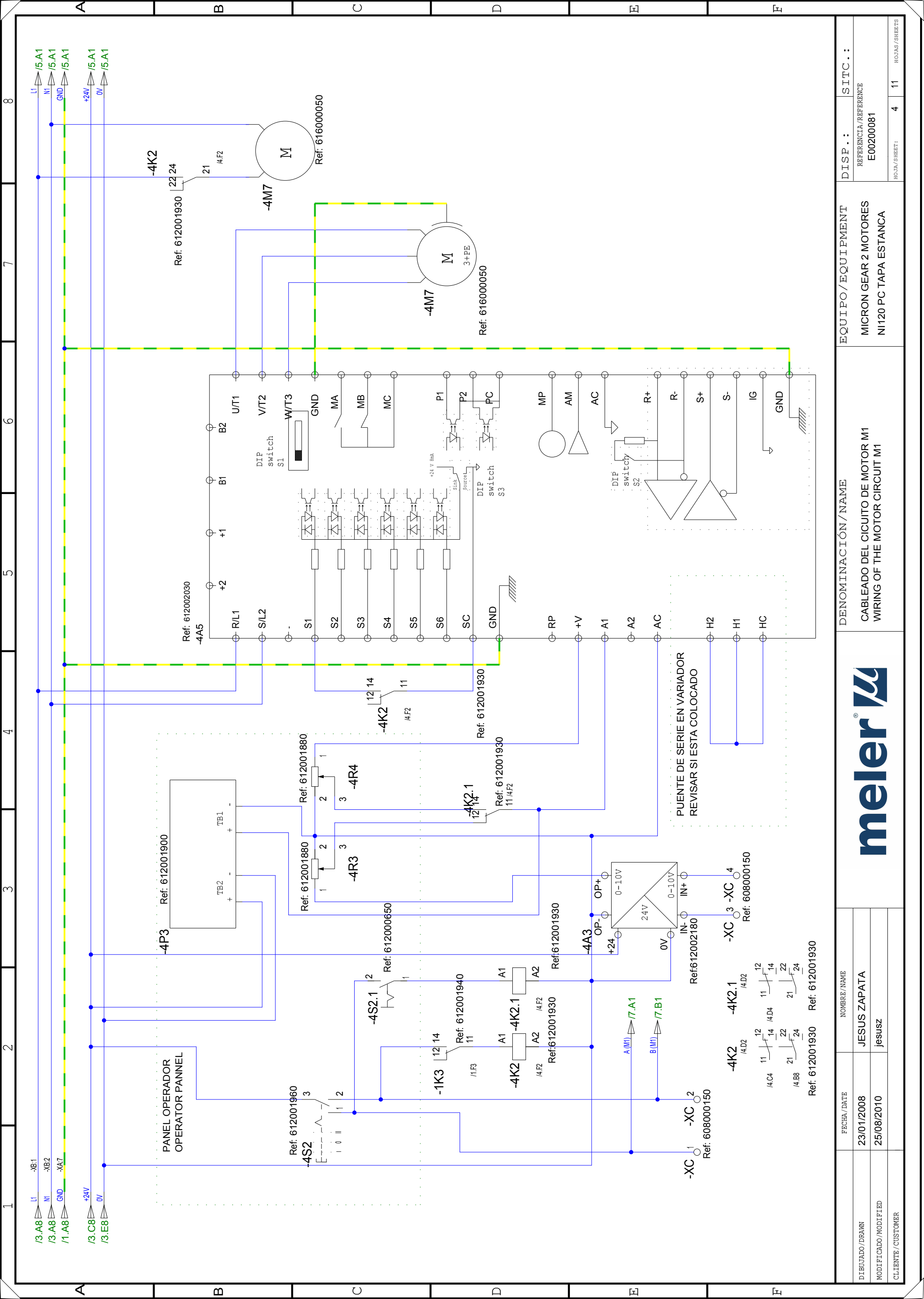

DISP. . :	SITC. . :
REFERENCIA/REFERENCE	E00200081
HORA/SHEET:	4 11
	HOURS/SHEETS

EQUIPO/EQUIPMENT
MICRON GEAR 2 MOTORES
 N1120 PC TAPA ESTANCA

DENOMINACIÓN/NAME
CABLEADO DEL CICIUTO DE MOTOR M1
WIRING OF THE MOTOR CIRCUIT M1



FECHA/DATE	NOMBRE/NAME	
23/01/2008	JESUS ZAPATA	
25/08/2010	jesusz	
CLIENTE/CUSTOMER		

Ref: 612001930 Ref: 612001930

PUENTE DE SERIE EN VARIADOR
 REVISAR SI ESTA COLOCADO

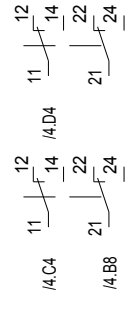

-XC 3 -XC 4
 Ref: 608000150

-4K2 -4K2.1
 /4.D2

-XC 1 -XC 2
 Ref: 608000150

-4K2 -4K2.1
 /4.F2

-4A3
 Ref: 612001930

Ref: 612001930

Ref: 612001930

Ref: 612001930

Ref: 612001930

Ref: 612001930

Ref: 612001930

Ref: 612001930

Ref: 612001930

Ref: 612001930

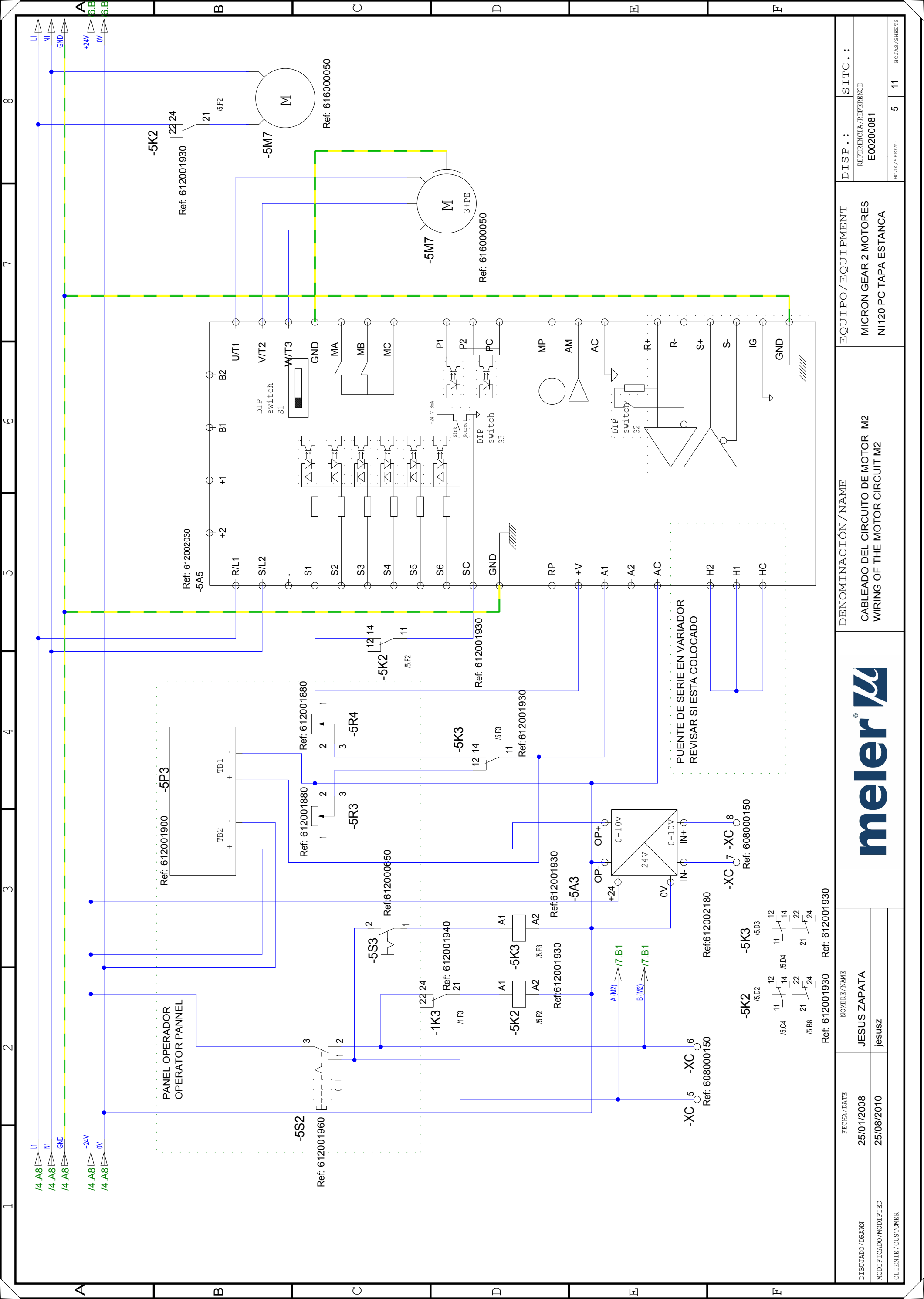

DISP.:	SITC.:
REFERENCIA/REFERENCE	E00200081
HORA/SHEET:	5 11

EQUIPO/EQUIPMENT
MICRON GEAR 2 MOTORES
 N1120 PC TAPA ESTANCA

DENOMINACIÓN/NAME
CABLEADO DEL CIRCUITO DE MOTOR M2
WIRING OF THE MOTOR CIRCUIT M2



FECHA/DATE	25/01/2008	NOMBRE/NAME	JESUS ZAPATA
DIBUJADO/DRAWN	25/08/2010	CLIENTE/CUSTOMER	jesusz

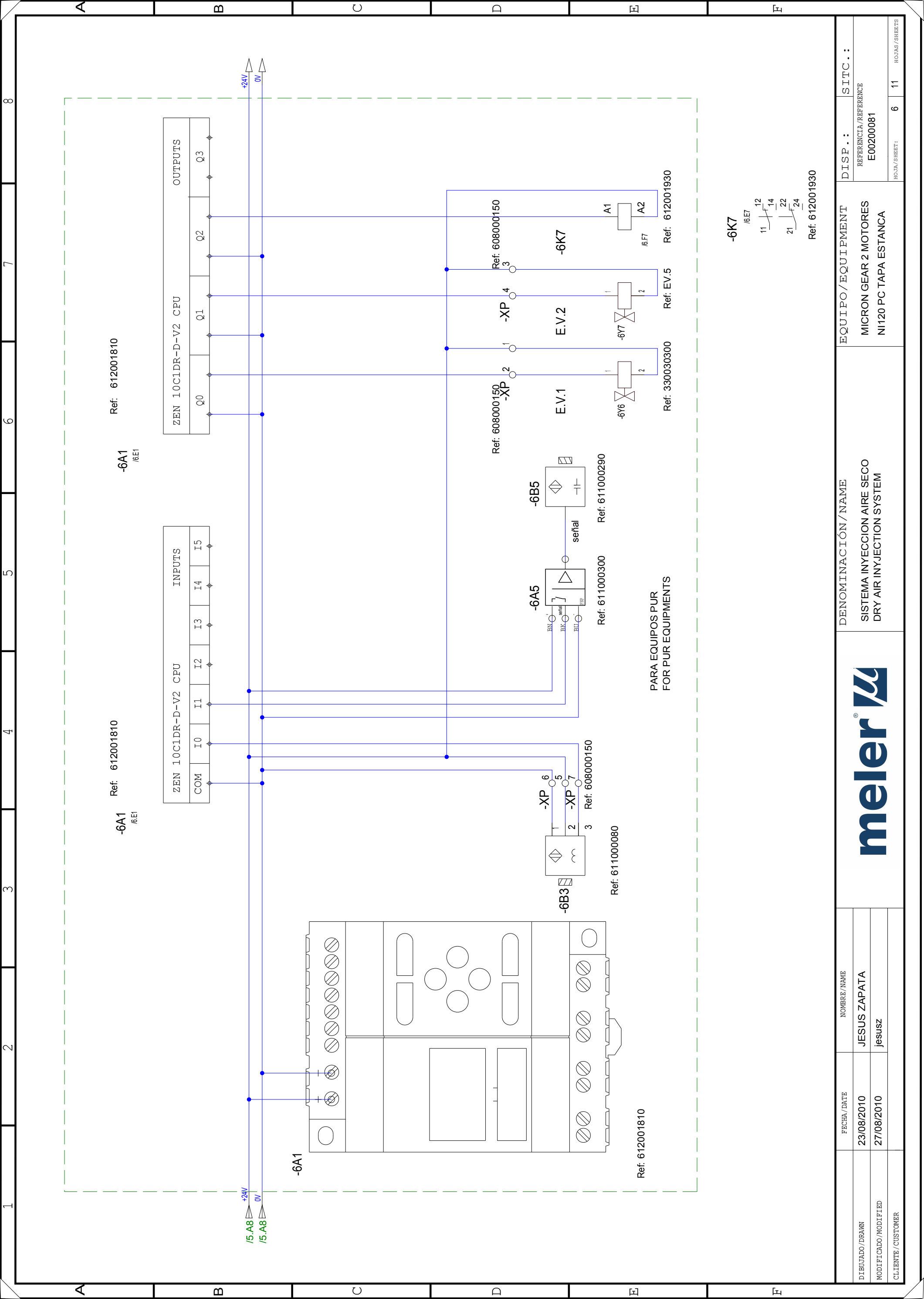

Ref: 612001810

-6A1
/6E1

Ref: 612001810

-6A1
/6E1

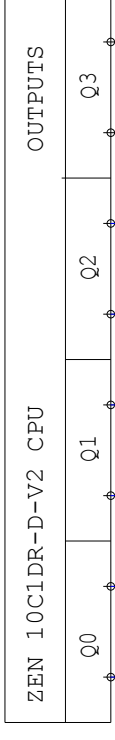
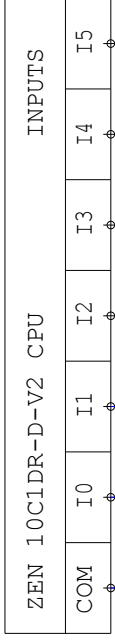

-6A1

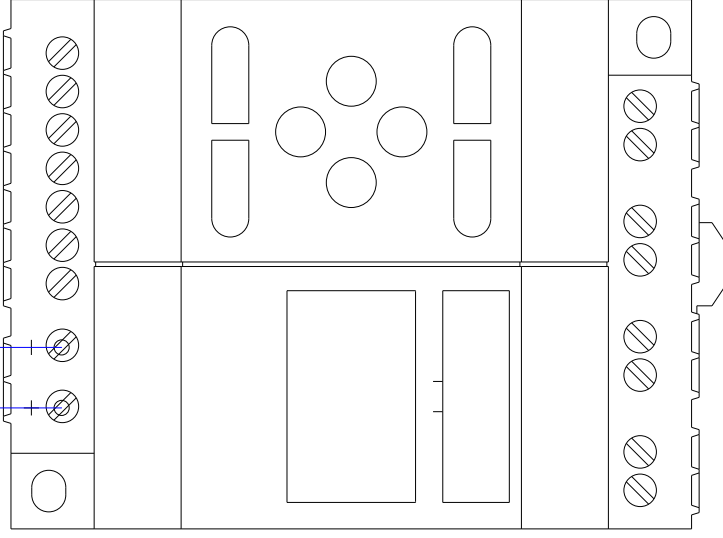

Ref: 612001810

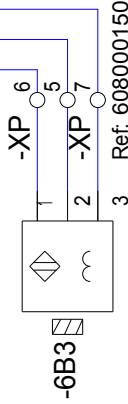

Ref: 611000080

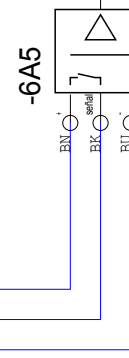

Ref: 611000300

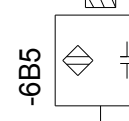

Ref: 611000290

Ref: 608000150

Ref: 608000150

Ref: 608000150

-6K7

-6K7

-6K7

PARA EQUIPOS PUR
FOR PUR EQUIPMENTS

-6K7

/6E7

11 12

14

21 22

24

Ref: 612001930

FECHA / DATE	NOMBRE / NAME	EQUIPO / EQUIPMENT	DISP . . :	SITC . . :
23/08/2010	JESUS ZAPATA	MICRON GEAR 2 MOTORES	REFERENCIA / REFERENCE	
27/08/2010	jesusz	N1120 PC TAPA ESTANCA	E00200081	
			HORA / SHEET:	6 11
				HOURS / SHEETS

DENOMINACIÓN / NAME
SISTEMA INYECCION AIRE SECO
DRY AIR INJECTION SYSTEM



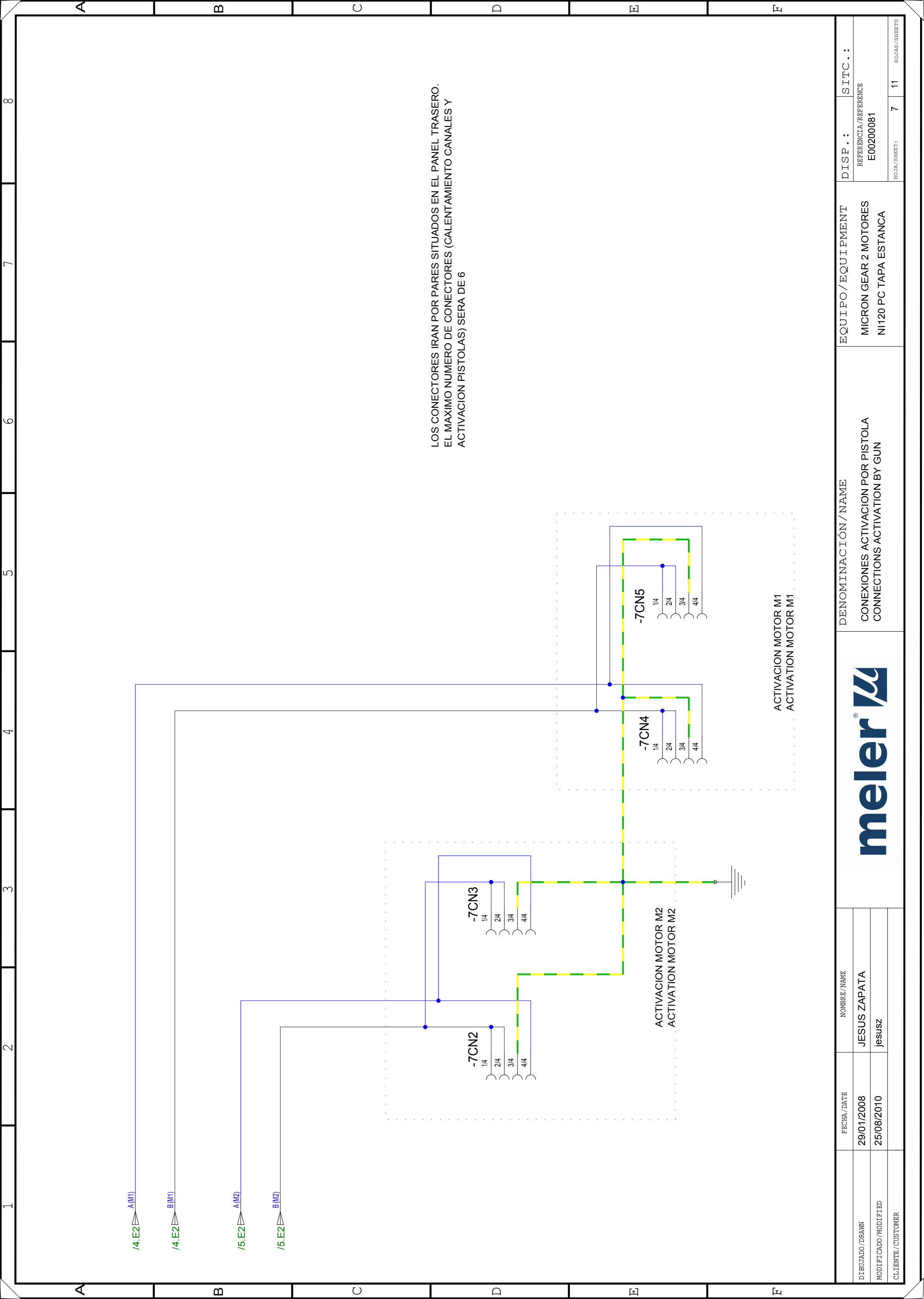

LOS CONECTORES IRAN POR PARES SITUADOS EN EL PANEL TRASERO.
 EL MAXIMO NUMERO DE CONECTORES (CALENTAMIENTO CANALES Y
 ACTIVACION PISTOLAS) SERA DE 6

		DENOMINACIÓN / NAME CONEXIONES ACTIVACION POR PISTOLA CONNECTIONS ACTIVATION BY GUN		EQUIPO / EQUIPMENT MICRON GEAR 2 MOTORES N1120 PC TAPA ESTANCA		DISP.: SITC.: REFERENCIA / REFERENCE E00200081	
FECHA / DATE 29/01/2008 25/08/2010	NOMBRE / NAME JESUS ZAPATA jesusz				HOJA / SHEET: 7 11		HORAS / SHEETS

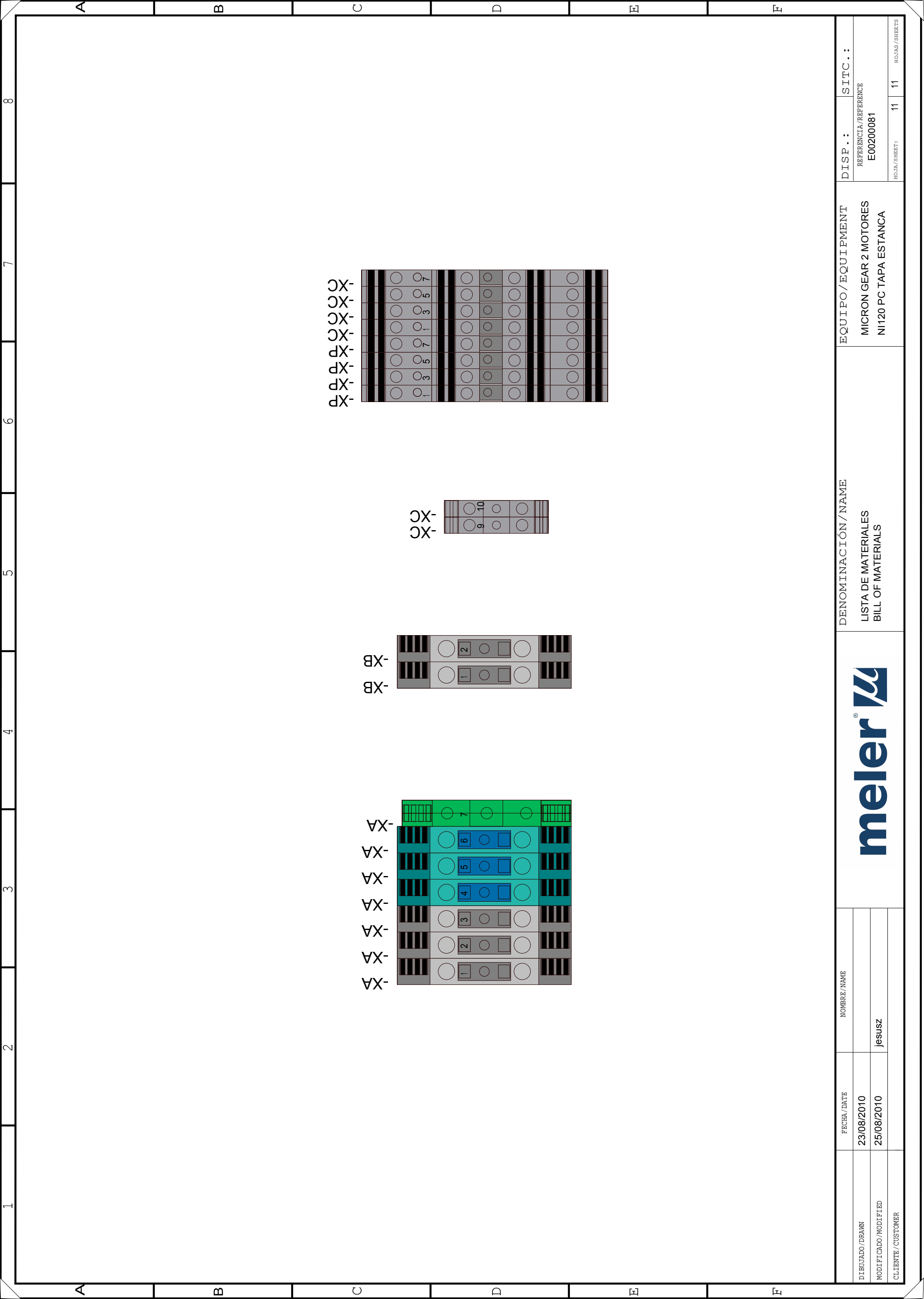

FECHA / DATE		NOMBRE / NAME		EQUIPO / EQUIPMENT		DISP. .:		SITC. .:	
23/08/2010		LISTA DE MATERIALES BILL OF MATERIALS		MICRON GEAR 2 MOTORES N1120 PC TAPA ESTANCA		REFERENCIA / REFERENCE E00200081			
MODIFICADO / MODIFIED		CLIENTE / CUSTOMER				HOJA / SHEET:		11 11	
25/08/2010		jesusz				HOURS / SHEETS		11 11	



A8. PNEUMATIC DIAGRAM

Components list

This appendix belongs to 32 liters version but its operation and working process are identical to the other versions of 'micron gear' series (see chapter '8. *Pneumatic diagram*' in this manual).

This page is intentionally left blank.

A9. SPARE PARTS LIST

The most common spare parts list of the micron series adhesive melters is shown in this chapter to give you a quick and sure guideline to choose them.

The spare parts are listed by groups in a natural order as they are located on the units.

As a visual help the manual includes drawings of the components with a drawing number to easy find them through the list.

The list gives you the part number and description, showing if it is necessary, if the part number belongs to a 4, 8,16 or 32 liters unit.

This appendix belongs to 32 liters version but its operation and working process are identical to the other versions of 'micron gear' series (see chapter '9. Spare parts list' in this manual).



Reference	Description
150028900	PTFE coated tank micron32 gear
150028910	Complete tank assembly micron32 gear
150028770	Tank port housing micron32
150028780	Tank gasket micron32
150028790	Insulation mantle micron32
150028810	Tank bottom insulation mantle micron32 gear
150028820	Level detector assembly micron32
150028830	Tank grid micron32
150028460	Front movable housing micron32 (*)
150028490	Rear movable housing micron32 (*)
150028520	Right side movable housing micron32 (*)
150028550	Tank left side fixed housing micron32 (*)
150028580	Lid housing micron32 (*)
150028610	Lid assembly micron32 (*)

(*) Light grey color references. Ask for other colors.

Air-tight lid

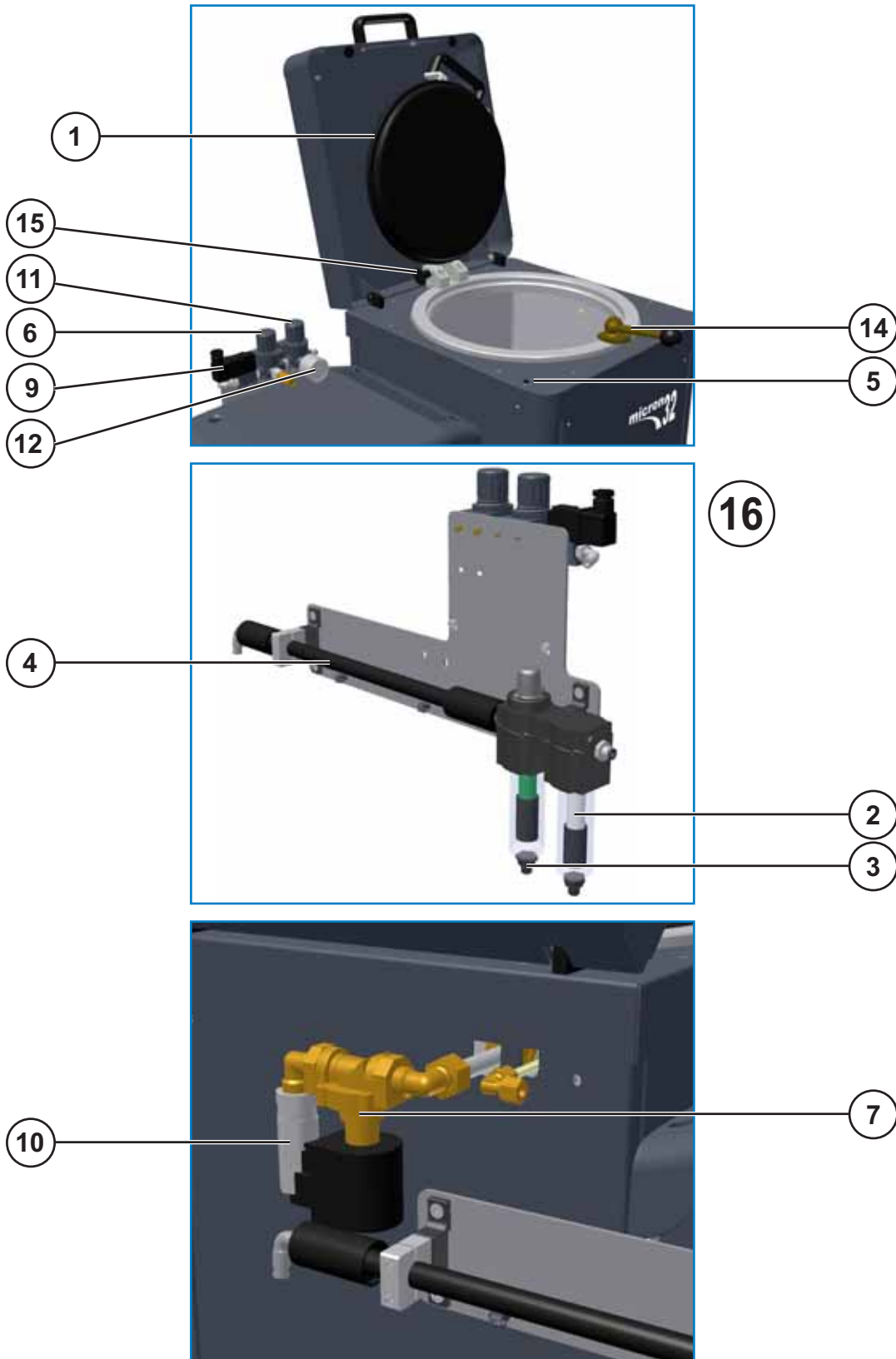

Air-tight lid

No.	Ref.	Description
1	150110080	Ø4 micron32 air-tight lid seal
2	150110040	Air filter Excelon series F72G-2GN-AL1 (G1/4)
3	150110050	Air filter Excelon series F72C-2GD-AL0 (G1/4)
4	150110060	Air dryer cartridge W07M
5	150110070	Inductive detector M8X1 (SRC-MD8PL)
6	10110031	Pressure regulator
7	150028400	Solenoid valve 2/2 NA 24V DC 18W
8	150028380	Pneumatic pressure limit valve 0.5 bar 1/4'
9	150028420	Solenoid valve 3/2 1/8 24V DC 5.4W
10	150028410	Non-return valve female-female 3/8' 0.05 bar
11	150029890	Pressure regulator 0,1-0,7 bar
12	150029900	Pressure gauge 0-1,6 bar
13	150025600	Omron Zen programmable relay
14	150028090	Fixing lever
15	150028100	Lid hinge blocking pin
16	150025880	Dry air system complete

This page is intentionally left blank.